



OCTOBER 1999



## Commodore's Comments

The Junior and Senior World Championships have now been successfully completed in Almería and Santiago de la Ribera, respectively. SCIRA Spain, Club Real de Regatas in Santiago, and Club de Mar, Almería all did wonderful jobs in handling the incredible number of details required both on-shore and on-the-water in hosting these complex events. Our Snipe class motto, "Serious Racing...Serious Fun", was upheld in fine fashion at both of these events. Both competitions were world championships of which we can all be very proud.

Congratulations to the new SCIRA Junior World Champion and Crew from Argentina, Lucas Gomez and Marcos Montanaro and the Runners-up from Spain, Francisco Sanchez and Matios Ros. Congratulations to the new SCIRA World Champion and Crew from Cuba, Nelido Manzo and Octavio Lorenzo (also recent PanAm Games Gold Medalists) and the Runners-up from Brazil, Andre Fonseca and Rodrigo Duarte. They are all well deserved champions and represent the Snipe Class very well.

Besides the championships, the SCIRA Board of Governors met in Santiago de la Ribera for several days of very productive meetings. It should be remembered that the SCIRA International Board of Governors is a working Board with the potential for important change occurring throughout the year. However the convergence of the Snipe class at the site of the World Championships is the

prime opportunity to meet face to face every two years and get things done.

Motions passed by the Board will be published in the November Snipe Bulletin in detail and have already appeared in preliminary form on the Snipe e-mailing list. Following is a recap of some of the more important changes, which will be implemented for Year 2000:

- SCIRA membership has been redefined without losing the critical importance of boat ownership. The opportunity now exists to be a SCIRA member without being a boat owner, but rather the member of an entity, which owns Snipes. Also, we must all sign up our crews to be members of SCIRA worldwide. All members of SCIRA International will receive the new International Bulletin and a Rulebook. This opens up new areas of untapped revenue dollars and direct communication with members for SCIRA.
- A revamped and completely International Snipe Bulletin will be unveiled in Year 2000. All members worldwide will receive 2-3 issues per year covering international news, rules changes, and reports on international events only. Regional regatta coverage will continue with already existing regional publications and newsletters. This change opens up completely new communication lines and promotion to our own membership, which

has not existed previously.

- The carbonfibre centerboard was approved for a final round of testing and a Board vote for final acceptance (or rejection) by July 31, 2000.
- Advertising under ISAF Category Crules (individual advertising allowed as restricted by individual class rules) will be allowed in events up and including national championships by approval of the national secretary and subject to SCIRA restrictions. Category C not allowed in SCIRA International events (Worlds, Europeans, WHO, Jr. Worlds, etc).

There were several important rules changes affecting the boat, measurement, and race management, but I will not try listing them all here. The changes listed above are very significant SCIRA organization changes, which will have very positive impacts on the class going forward. Many of these changes require important implementation and detailed definition in the near future, so stay tuned for those details. Feedback from membership to Board members on these changes is very valuable and is encouraged. Remember that your Board of Governors continues to work year round.

--Lee Griffith

### Statement of ownership, management and circulation

Required by 39 U.S.C. 3685

1. Publication title: Snipe Bulletin
2. Publication No.: 08996288
3. Filing date: October 1, 1999
4. Issue frequency: monthly
5. Number of issues published annually: Ten
6. Annual subscription price: \$10
7. Publication office: 1833 Tustin St., San Diego, CA 92106
8. Business office: 1833 Tustin St., San Diego, CA 92106
9. Name and address of publisher, editor, managing editor: Jerelyn Biehl, 1833 Tustin St., San Diego, CA 92106
10. Owner: Snipe Class International Racing Association, 1833 Tustin St., San Diego, CA 92106
11. Know bondholders, mortgagees and other security holders owning 1% or more of total amount of bonds, mortgages or other securities: None.
12. Not applicable
13. Publication Title: Snipe Bulletin
14. Issue date for Circulation data below: August 1999
15. Extent and Nature of Circulation:

	Average # copies each issue for preceeding 12 months	Actual # copies of single issue nearest filing date
a. Total No. copies (net press run)	1350	1350
b. Paid and/or requested circulation		
1. Paid/freq. outside county	84	815
2. Paid in county subscriptions	54	65
3. Sales through dealers	0	0
4. Other classes mailed through USPS	0	0
c. Total paid and/or requested circulation	898	880
d. Free distribution by mail	40	40
e. Free distribution outside the mail	360	247
f. Total free distribution (sum of d & e)	400	287
g. Total distribution (sum of c & f)	1298	1167
h. Copies not distributed:	52	183
i. Total (sum of g & h)	1350	1350
j. Percent paid and/or requested circulation	69%	75%

16. Statement of ownership is printed in the October issue
17. I certify all information on this form is true and complete.

Jerelyn Biehl, Publisher

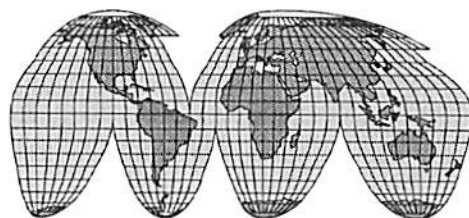

## Around the Snipe World

**NOVEMBER BULLETIN** will have all the new rules changes, minutes from National Secretaries and Board of Governors meetings at the 1999 World Championship

**ADDRESS CHANGES**  
**European National Secretary**  
 Ezio Braga: new e-mail  
 braga@meplas.com

**Uruguay National Secretary**  
 Pedro Garra: new e-mail  
 pgarra@movinet.com.uy

**OFFICERS CHANGES**  
 Please forward new National Secretary, District Governor and Fleet Captain contact information to the SCIRA office for 2000 mailings.





25172

2728

2945

2667

USA  
273

# 1999 Snipe World Championship - Santiago de la Ribera, Spain

Skipper/Crew	Country/sail#	Finishes	Total
1. Nelido Manzo/Octavio Lorenzo	CUB 29518	(20)-6-1-2-7-4-5	24.75
2. André Fonseca/Rodrigo Duarte	BRA 29254	1-(p20)-5-5-12-5-4	31.75
3. Fernando Rita/Javier Sintes	ESP 29376	(23)-p20-4-7-3-7-2	36
4. Aureliano Negrin/David Martin	ESP 29145	21-p20-(dsq)-1-5-2-3	45.75
5. Carlos Martinez/Alberto Vadell	ESP 29607	12-p20-(30)-19-1-1-1	57.25
6. Ricardo Fabini/Ignacio Saralegui	URU 28026	(29)-4-2-9-16-24-13	68
7. Bruno Bethlem/Fernando Krahe	BRA 29445	2-17-(34)-20-9-11-14	73
8. Valery Ushkov/Mikhail Vedenev	RUS 29480	17-(39)-16-13-15-6-10	77
9. Augie Diaz/Gonzalo Diaz, Sr.	USA 28810	6-12-22-6-(24)-15-17	78
10. Damian Borrás/Juan Magro	ESP 29505	18-p20-(27)-4-11-3-22	79
11. George Szabo/Eric Wilcox	USA 29672	5-10-19-21-19-(22)-19	93
12. Matias Pereira/Marcus Behrendt	ARG 28211	4-20-9-17-(dsq)-32-15	97
13. Mauricio Santa Cruz/Vianna Vianna	BRA 29530	25-(p20)-p20-8-4-19-6	98
14. Ivan Pimentel/Pedro Caldas	BRA 29654	(28)-p20-13-14-20-8-28	100
15. Paulo Santos/Dante Bianchi	BRA 29639	10-15-38-23-2-12-(39)	100
16. Yoshihiro Okinishi/Daiki Ideta	JPN 28722	8-7-10-28-27-23-(35)	103
17. Morten Ullman/Kim Hyttel	DEN 29519	22-p20-(36)-18-13-9-8	104
18. Pablo Fresneda/Carlos Carmona	ESP 29580	9-40-20-16-8-16-(ret)	109
19. Oliver Gongora/Alejandro Fresneda	ESP 28920	7-25-26-(34)-6-29-23	116
20. Luis Soubie/Cecilia Granucci	ARG 28701	38-21-7-(41)-25-14-11	116
21. Enrico Michel/Stefano Longhi	ITA 29812	(46)-14-43-22-23-13-9	124
22. Federico/Felipe Vasconcellos	BRA 29612	15-(p20)-37-26-14-21-12	125
23. Shigeo Takamura/Satoru Maruyama	JPN 29391	3-18-11-(dnf)-30-41-24	127
24. Enrico/Franco Solerio	ITA 29571	36-(46)-40-3-10-38-7	134
25. Manuel/Eduardo Fumagallo	ARG 12733	33-(p20)-21-15-26-18-29	142
26. John Jackman/Steve Stewart	CAN 29646	12-13-29-30-32-(37)-26	142
27. Pal Bratbak/Michel Irgens	NOR 29152	34-23-28-27-17-(35)-18	147
28. Tiago Roquette/Raul Bulhao	POR 29292	(35)-32-14-24-18-33-27	148
29. Pedro Lorson/Watt Duffy	USA 28044	19-34-6-(42)-37-20-33	149
30. Yuzo Morita/Tatsuhiko Tokunaga	JPN 29392	(37)-37-33-25-29-10-20	154
31. Dmitry Berezkin/Mikhail Krutikov	RUS 29490	14-16-12-(dsq)-dnc-27-p20	154
32. Birger jansen/Liv Ulveic	NOR 29630	16-(42)-31-10-35-40-25	157
33. Peter Iversen/Chris Pedersen	DEN 29539	24-p20-8-32-(dnf)-25-40	160
34. Eduardo Santambrogio/Gonzalo Martinez	ARG 28646	(ocs)-p20-15-11-dnf-17-54	171
35. Jean Jacques Frebault/Gilles Boisaubert	FRA 29322	39-(p20)-p20-12-39-36-31	172
36. Shigeru Matsuzaki/Masanobu Ono	JPN 29288	11-31-(39)-33-33-31-36	175
37. Hal Gilreath/Alex Stout	USA 29324	31-35-25-(40)-36-34-21	182
38. Roberto Fabini/Santiago Gari	URU 28826	27-36-17-37-(40)-28-38	183
39. Miguel Leita/Pedro Ambrosio	POR 28818	30-28-23-36-34-(43)-32	183
40. Bjorn Forslund/Lisa Gehrken	NOR 29454	26-(p20)-18-29-28-dnf-p20	199
41. Gabriele Bernardis/Stefano Pontalti	ITA 27109	(43)-38-32-35-22-39-34	200
42. Per Anders Johanssen/Karin Petterssen	SWE 27856	44-33-(ocs)-31-31-26-41	206
43. Miguel Bunte/Jorge Sabido	POR 29370	48-43-46-47-21-30-(ocs)	235
44. Robert Dunkley/Ted Smith	BAH 29210	41-(47)-41-44-38-45-37	246
45. Guy Celis/Yves Ratinckx	BEL 29115	40-(48)-42-39-45-48-45	259
46. Thierry Den Harting/Greet Jansen	BEL 27141	(49)-49-35-46-41-46-42	259
47. Mattias Alm/Fredrik Hansson	SWE 29455	42-p20-44-(49)-43-47-44	262
48. Bo Lidsjo/Bodil Lidsjo	SWE 29149	47-p20-(ocs)-43-48-44-43	278
49. Gweneth Crook/Monique Gaylor	CAN 25843	32-51-49-(53)-49-52-49	282
50. Confoulan/Etcheber	FRA 27847	45-(52)-47-48-47-49-47	283
51. Claus Carpelan/Freddy Weglius	FIN 29019	53-(p20)-p20-38-46-42-48	284
52. Iain Marshall/Richard Marshall	GBR 29501	50-50-(ret)-51-42-54-46	293
53. Juha Pekka Vourinen/Rene Nurmi	FIN 28707	51-(54)-48-45-51-50-50	295
54. Brian Gregory/Ian Gregory	GBR 28451	(55)-50-52-44-51-51-54	300
55. William Kemenes/Roberto Londono	COL 24189	(54)-53-51-50-50-53-52	309
56. Margit Hautman/Gerard Hautman	GER 27024	56-56-52-dnf-(dnc)-dnf-53	329
57. Gunter Hautman/Angelika Brich	GER 26509	55-(57)-dnf-dnc-dnc-dnc-dnc	340

# Argentines Gomez/Montanaro Oust Spanish for Jr. World Title

In unusually light conditions for the venue, 18 year old Lucas Gomez and 19 year old Marcos Montanaro of Argentina, won the last race to claim the 1999 Jr. Snipe World Championship title in Almería, Spain, August 17-21. Both Spanish teams of Paco Sanchez/Matias Ros and Raul Valenzuela/Carlos Carmona, were leading 1-2 into the last day of the Championship. With all races but one sailed in winds under 12 knots, not all races could be sailed and there were no throw-out races. The Race Committee moved the start time up the last day to 11:00 and amended the Sailing Instructions to attempt 3 races to give the competitors a throw-out, but the wind would not cooperate and only one race was held on the final day.

22 teams from 12 countries competed for this years championship with 12 sailors returning to the Jr. Worlds for their second time to compete. The Deed of Gift for the Vieri Lasinio De Castelvero Jr. World trophy states that a competitor must not turn 20 years in the year of competition. The youngest sailor was 14 year old Sean Adams of the US.

After formal Opening Ceremonies at the Club de Mar Almería, the sailors were off for their first day of competition. Only one race was held in perfect winds of 8-12 knots. Gomez/Montanaro, Jr. World veterans Pablo Defazio/Diego Stefani of Uruguay and Dustin Kays/Sean Adams of the US, started at the pin and hit the left side to lead around the weather mark. Gomez/Montanaro held their lead the entire race with Danes Thomas Rasmussen/Chris Pedersen climbing to a 2nd place finish.

The second day started in about 6 knots of breeze with Kays/Adams port tacking the fleet in a clean start. At the weather mark it was Defazio/Stafani of Uruguay, Kays/Adams of the US and Emanuel Botello/Lewis Marcos of Argentina followed by Roberto Paradedá/Daniel Ortega of Brazil and local favorite Raul Valenzuela/Carlos Carmona of Spain to round out the top 5. The Uruguayans held and lengthened their lead while the rest of the pack had a tight rounding at the last leeward mark rounding. By the finish, Women's World champions Ekaterina Skudina and Tatiana Lartseva of Russia had squeaked out of the pack and in good tactical moves, held Argentines Gomez/Montanaro, who had also climbed through the pack, to

the finish. Anxious to finish, the Argentines tacked too early, tagging the Russians stern. This cost them 2 places and a 720 - a hard lesson to learn. The breeze picked up to 12-15 knots for the third race with the seas becoming choppy and confused. The Spanish teams of Sanchez/Ros and Valenzuela/Carmona showed the fleet the way around the course and finished 1-2 respectively. They repeated this on the second day, even in the light breeze. The RC postponed the start on day 3 because of shifting winds. After hours in the club swimming pool, any hint of breeze made the competitors anxious to race, and finally the RC sent the sailors out for one race in the light breeze.



photo above: Lucas Gomez & Marcos Montanaro celebrate being World Champions!

On the final day, the sailors were sent out early, but only a single race was held to complete the championship.

SCIRA Spain and the Club de Mar Almería did an excellent job organizing the Championship. The facilities were incredible, offering the juniors a huge swimming pool to play in waiting for the wind. Also available were tennis, soccer, basketball and other activities.

## 1999 Snipe Junior World Championship Almería, Spain

	Skipper/Crew	Country/Sail #	Finishes	Total
1.	Lucas Gomez/Marcos Montanaro	ARG 29230	1-5-10-4-1	20.5
2.	Francisco Sanchez/Matias Ros	ESP 28764	8-10-1-1-2	21.5
3.	Raul Valenzuela/Carlos Carmona	ESP 9779	10-4-2-2-4	22
4.	Roberto Paradedá/Daniel Ortega	BRA 29366	4-3-5-7-8	27
5.	Pablo Defazio/Diego Stafani	URU 28024	11-1-3-12-3	29.75
6.	Frederico Vasconcellos/P. Mascarenhas	BRA 29612	5-19-4-8-5	41
7.	Emanuel Botello/Lewis Marcos	ARG 27860	13-6-8-6-10	43
8.	Ekaterina Skudina/Tatiana Lartseva	RUS 29480	14-2-14-3-13	46
9.	Santiago Silveira/Alejandro Foglia	URU 27785	cnf-12-9-10-7	50
10.	Maria Skoliapova/Mikhail Kondratyev	RUS 29490	6-11-16-9-12	54
11.	Jorge Gonzales/Tomas Depolo	CHI 28840	19-9-7-5-15	55
12.	Thomas Rasmussen/Chris Pedersen	DEN 26470	2-dnc-11-11-11	57
13.	Dustin Kays/Sean Adams	USA 25071	12-7-12-20-6	57
14.	Otto Nielsen/Peter Jacobsen	DEN 29020	9-16-6-13-14	58
15.	Francisco Mesquita/Artur Cortereal	POR 28028	3-8-18-17-17	63
16.	Philip Marshall/Duncan Read	GBR 29501	17-17-13-18-16	81
17.	Lee Sackett/Grant Glass	USA 28575	15-14-17-19-18	83
18.	Thomas Mercante/Marco Mazzeo	ITA 28817	18-15-20-14-19	86
19.	Andrea Garibbo/Simone Ricci	ITA 28771	cnf-18-21-15-9	88
20.	Viktor Sinding Larsen/Jonas Stromquis	NOR 19428	16-13-15-22-ocs	91
21.	Alexandre Soares/Nuno Vasconcelos	POR 29407	20-dsq-22-16-20	102
22.	Magnus Hedmark/Lars Oppkvitne	NOR 22802	21-20-19-21-21	102

# Nickels Boat Works 1999 Snipe

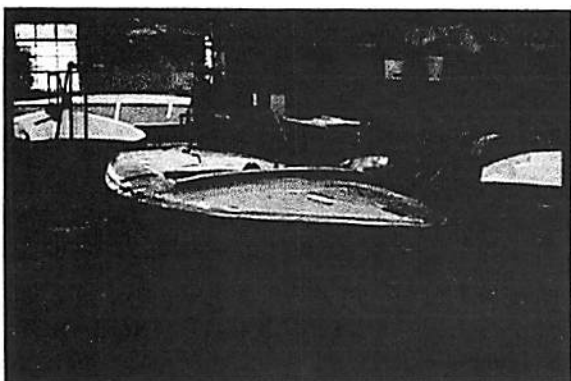

**High Quality Construction**  
Unique Nickels hull shape, very full forward with maximum roundness all the way to the transom

A NBW Snipe has an extremely deep cockpit giving the crew more room keeping their knees out of their chests

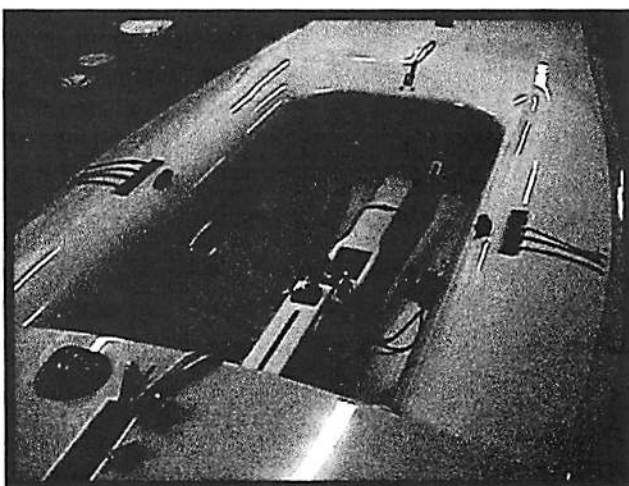

**Nickels Boat Works Snipes are ready to sail when delivered.**

Order now and avoid the November 1st price increase

Contact

**Nickels Boat Works**

**2426 South Long Lake Road**

**Fenton, MI 48430**

**810 750-1855**

**810 750-0501 (Fax)**

**E-Mail [Nickelsboatworks@juno.com](mailto:Nickelsboatworks@juno.com)**

# FIREWATER REGATTA & DISTRICT II CHAMPIONSHIP

Lincoln Snipe Fleet #567, Lincoln Nebraska  
June 26 & 27, 1999

## FINAL RESULTS

Place	Name	Home Fleet	Boat#	Finishes	Total
<b>A Fleet:</b>					
1	Jon Christensen/Susie Wahl	Lincoln #567	24042	1 3 2 7 1	13.5
2	Blaine/Adrienne McCleskey	Rocky Mountain #210	28361	4 1 6 1 3	14.5
3	Carter Weitz/Tami Weitz	INSA #309	25486	2 4 4 3 2	15
4	Andy Towles/Katy Towles	Oklahoma City #14	29808	11 5 5 4 4	29
5	Jim Russell/Rachel Russell	Lincoln #567	28881	13 2 1 13 5	33.75
6	James Rix/Ken Rix	Wichita #93	29313	9 14 3 5 8	39
7	Martin Bebb/Carole Veir	Sequoyah #68	25517	8 10 14 6 7	44
8	Ed Weitz/Libby Raus	INSA #309	28482	12 12 7 12 9	52
9	John Briggs/Joseph Briggs	Lincoln #567	25731	3 7 21 17 6	54
10	Bob Ewoldt/Faye Sabata	Lincoln #567	25552	5 13 16 10 10	54
11	Doug Swenson/Karen Swenson	Rocky Mountain #210	28900	17 8 14 11 12	62
12	Larry Briggs/Vicki Albert	Lincoln #567	27372	6 19 12 2 dns	63
13	Bill Brush/Tom Brush	INSA #309	27523	14 17 11 9 14	65
14	Pat Keane/Teresa Alexander	Lincoln #567	24321	7 9 19 8 dns	67
15	Carl Lundstrom/Julie Lundstrom	Rocky Mountain #210	24809	15 11 9 19 15	69
16	Fred Hegel/Ronnie Hegel	Rocky Mountain #210	29535	18 16 18 14 11	77
17	Jack Wagener/Cindy Prucha	Lincoln #567	28882	20 6 10 18 dns	78
18	Mary Ann Rix/Bill Loyd	Wichita #93	25785	10 15 20 20 13	78
19	Jim Lowrie/Beth Wahl	Rocky Mountain #210	28450	19 21 8 16 17	81
20	Robert Hoffmann/P. Pepeliaev	INSA #309	27570	21 23 17 15 18	94
21	John Bohling/Tonja Bohling	Lincoln #567	20197	16 18 dns dns dns	106
22	Bob Bischoff/Kris Caldeira	Rocky Mountain #210	20403	23 20 15 dns dns	106
23	John Layman/Marian Layman	Lincoln #567	21913	dns dns dns 21 16	109
24	Chuck Wahl/Cissie Smith	Lincoln #567	23822	22 22 22 dns dns	124
<b>B Fleet:</b>					
1	Erik Bengtsson/Rich Straebel	Lincoln #567	22810	1 1 2 4 4	11.5
2	Howard Parker/Mason Youngman	Lincoln #567	21604	2 3 6 1 1	12.5
3	Peter Guile/Greg Peterson	INSA #309	25487	4 2 4 2 2	14
4	Charles Culp/Mary Culp	INSA #309	23340	3 5 1 3 3	14.75
5	Brian Drahota/Bill Gustafson	Lincoln #567	21364	6 6 3 5 6	26
6	Ron Silver/Heather Silver	Lincoln #567	22327	5 4 7 dns 5	28
7	Rob Newton/Jessica Newton	Lincoln #567	14895	7 7 5 dns 7	33
<b>Juniors:</b>					
1	Tom Brush/Bill Brush	INSA #309	27523	1	.75
2	Rachel Russell/Jim Russell	Lincoln #567	28881	2	2
3	Joseph Briggs/John Briggs	Lincoln #567	25731	3	3
4	Jessica Newton/Rob Newton	Lincoln #567	14895	4	4

**WANTED**

Boats donated to  
Texas A&M University at Galveston  
contact: Gerard Coleman

Marine Engineering Department  
Texas A&M University at  
Galveston  
200 Seawolf Parkway  
Galveston, TX 77553

office: 409-740-4856  
fax: 409-740-4849  
home: 409-740-9437  
e-mail: coleman@tamug.tamu.edu

## For additional information:

Bill & Sherry Welch      PO Box 2154, St. Pete, Fl, 33731  
SPYC Sailing Secretary      11 Central Ave, St. Pete, Fl, 33701  
St Petersburg Yacht Club web page      www.spyc.org  
Snipe class web page      www.snipe.org

727-381-8255  
727-822-3873

sails@IntNet.net  
spyc.org

## Team Racing

By popular demand, we have added team racing to this regatta, as well as single-handed racing. Each team must have three boats; dig-up your old college team and bring them with you. Practice with your friends, or just show up and we will match you with other snipers already here.

This is sure to be a fun event.



# Dead Of Winter 2000



# Coach's Tips

What Are You Looking At? Upwind and down, your eyes are the most immediate source of critical data. Exercising a rhythm when gathering data will keep all the pertinent information flowing as needed. As you sail upwind check these areas one by one in succession, when you get done start all over again. The actual order is up to you, but discipline yourself to check in on all the areas. Your eyes should be constantly on the move.

## UPWIND

1) Luff of jib, check the telltales and keep them flowing. If you're fast maybe burn a little by pinching just a touch, if your feeling sluggish (the boat that is) then foot just a bit.

2) The Horizon; cross checking the angle of heel with the feel of the boat will keep you going fast. Every boat's taste for heel is different, learn what is fast for yours and maintain it with body weight, steering and sail trim.

3) Water; look out for puffs, lulls, flat water and choppy water. Keeping tabs on this information will allow you to make good tactical decisions and will assist you in making slight adjustments to course as you work your way through the waves.

4) Look Up; the leech of the main, make sure it is trimmed to perfection, this is the throttle, work it.

5) Look In; the boom and traveler setting. This should just be a quick check to make certain all is well.

6) Scan; quick check for other boats, right of way boats are one thing, clear air is another.

7) Leech of Jib; if your boat is set-up so you can see it easily from where you are steering, check it out. A telltale 75% of the way up with a window in the main is very handy for checking if the jib has flow.

## DOWNWIND

1) Luff of Spinnaker; same as the jib, keep it flowing

2) Horizon; check that angle of heel

3) Water; keep looking for puffs, lulls and waves; this time, however, a quick look over your shoulder will help in assessing the best possibility for the next puff.

4) Look Up; check the mainsail, sheet tension and vang tension to make certain you are keeping that top batten parallel to the boom, adjust that vang to do so.

5) Scan; look for other boats and make certain your air is clear.

— The Coach

*Sailweb is an interactive "real-time" tele-coaching service designed for you to access information and techniques about racing sailboats that is pertinent to you. For more information, access [www.sailweb.net](http://www.sailweb.net)*

## 1999 Danish National Championship

July 1-4, Horsens, Denmark

### Skipper/Crew

1. Peter Iversen/Jesper Kristensen
2. Preben Kristensen/Johan Hansen
3. Jonatan Persson/Christine Schultz
4. Thomas Iversen/Andreas Godtfredsen
5. Morten Ullmann/Kim Hyttel
6. Thomas Weber/Brian Willumsen
7. Thomas Rasmussen/Chris Pedersen
8. Henrik Andersen/Peter Sølvér
9. Jesper Larsen/Joan Larsen
10. Søren Andersen/Johan Sædholm
11. Jan Persson/Jane Persson
12. Otto Nielsen/Peter Jacobsen
13. Jakob Sørensen/Søren Adneren
14. Anne Marie Hansen/Jannik Hansen
15. Bent Dahl/Mark Johansen
16. Henning Sørensen/Jakob Frost
17. Søren Thomsen/Andrea Bøje

### Fleet

- Horsens
- Horsens
- Espergærde
- Horsens
- Espergærde
- Espergærde
- Horsens
- Espergærde
- Espergærde
- Horsens
- Espergærde
- Horsens
- Faaborg
- Espergærde
- Horsens
- Faaborg
- Faaborg

## Missouri Valley Championship

On Saturday July 3, 18 Snipes from the Midwest met at Lake Manawa for the 49<sup>th</sup> Annual Missouri Valley Championship. The weather forecast held true, and by the skippers meeting the wind speed had built to 30-35 mph with gust to 35+. In our zeal to get the competitors some races, we set a port triangle, but with the wind and wave conditions as they were, realized the necessity for postponing. After several more postponements, races were cancelled for the day. As a diversion during the afternoon the RC tried to initiate a friendly game of beach volleyball between the "roadies" and the "homies", unfortunately, the same winds that kept the fleet off the lake, kept the volleyball in the woods! That evening we were all treated to a wonderful steak dinner, door prizes and a fireworks display.

At the 8 am skippers meting conditions looked good, with wind speeds around 7-10 mph with flat water. However as luck would have it, by the 8:30 white flag sailors were greeted by a near mirror image of Saturday's conditions. While some boats remained at the dock and other turned back, we finally go the first race off. John and Mary Buckley took the right side and led to the finish. IN the second race, the Buckleys were looking good until that dreaded moment when the mast is under the boat. That allowed the team of Pat Keane and Jon Christensen, coming in from the left, to get the bullet. In the third race, James & Ken Rix, from Wichita, KS, played the right side for the win. As usually happens,

the winners of the regatta, Pat Flood and crew Joan Lappe, did not win a race, but sailed consistently for the top trophy.

We at INSA fleet 309 would like to thank all the crews for their support, not only for this year but all the years gone by. We invite you all to join us next year to help celebrate 50 years of Snipe Racing, good times, and great friendships on Lake Manawa.

—Bob Hoffman

1. Pat Flood/Joan Lappe
2. James/Ken Rix
3. John Sepanski/Chris Stahl
4. Pat Keane/Jon Christensen
5. John/Mary Buckley
6. Ed Weitz/Libby Weitz Raus
7. Bill/Mac Brush
8. Carter/Tami Weitz
9. Bob Recker/Kathlenn Smith
10. Katie/Andy Towles
11. George Rood/Jan Churchill
12. Bill/heather Dunbar
13. Charles/mary Culp
14. Mary Ann Rix/Bill Loyd
15. Glenn/Judy Ruff
16. Harry Crook/Jim O'Brien
17. Dan Stoney/Lisa Hughes
18. Jon/Katie Gondring
19. Rick Scofield/Tom Jetton

# Lillia Snipe

Working together with the world's best sailors, we thought, designed and built...

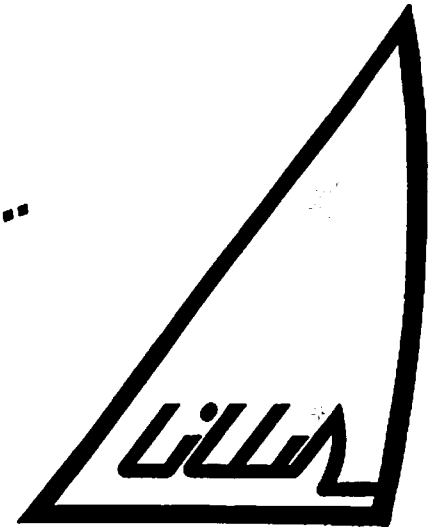

## New Lillia Snipe

- Computer designed hull for the best all-around performance.
- Deck modified with the most comfortable hiking position.
- Deck hardware lay-out thought for more simplicity and access.

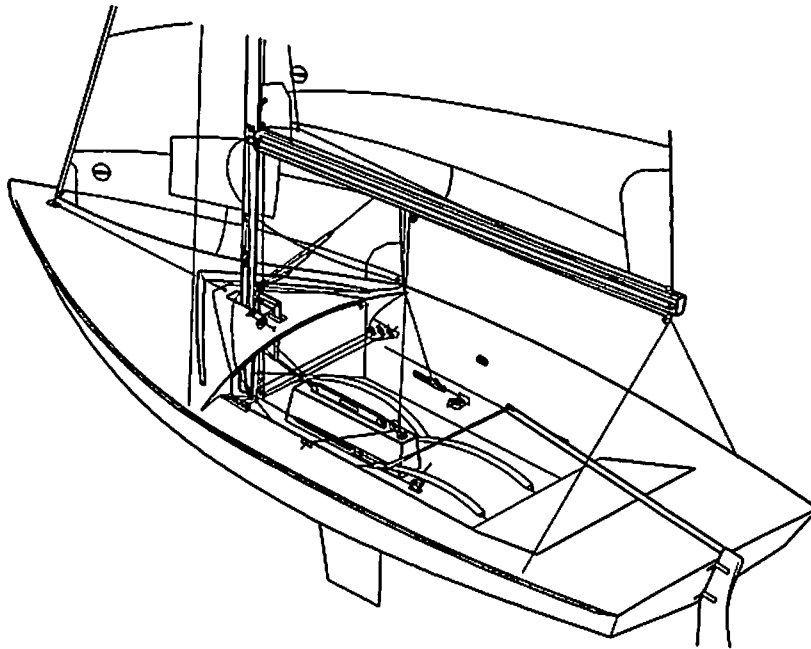

**LILLIA BOATYARD - 22010 Musso - Como - Italy - Phone 0039-344-81223 Fax 0039-344-81568**

**LILLIA SOUTH AMERICA**  
Niteròy - RJ  
Phone - Fax 0055-21-616-2550

**LILLIA NORTH AMERICA**  
190 Hagman Rd. - Winthrop, MA 02152  
d- 617-539-0992 e-617-846-1772  
Fax 617-539-0614