

SNIPE
.....
BULLETIN

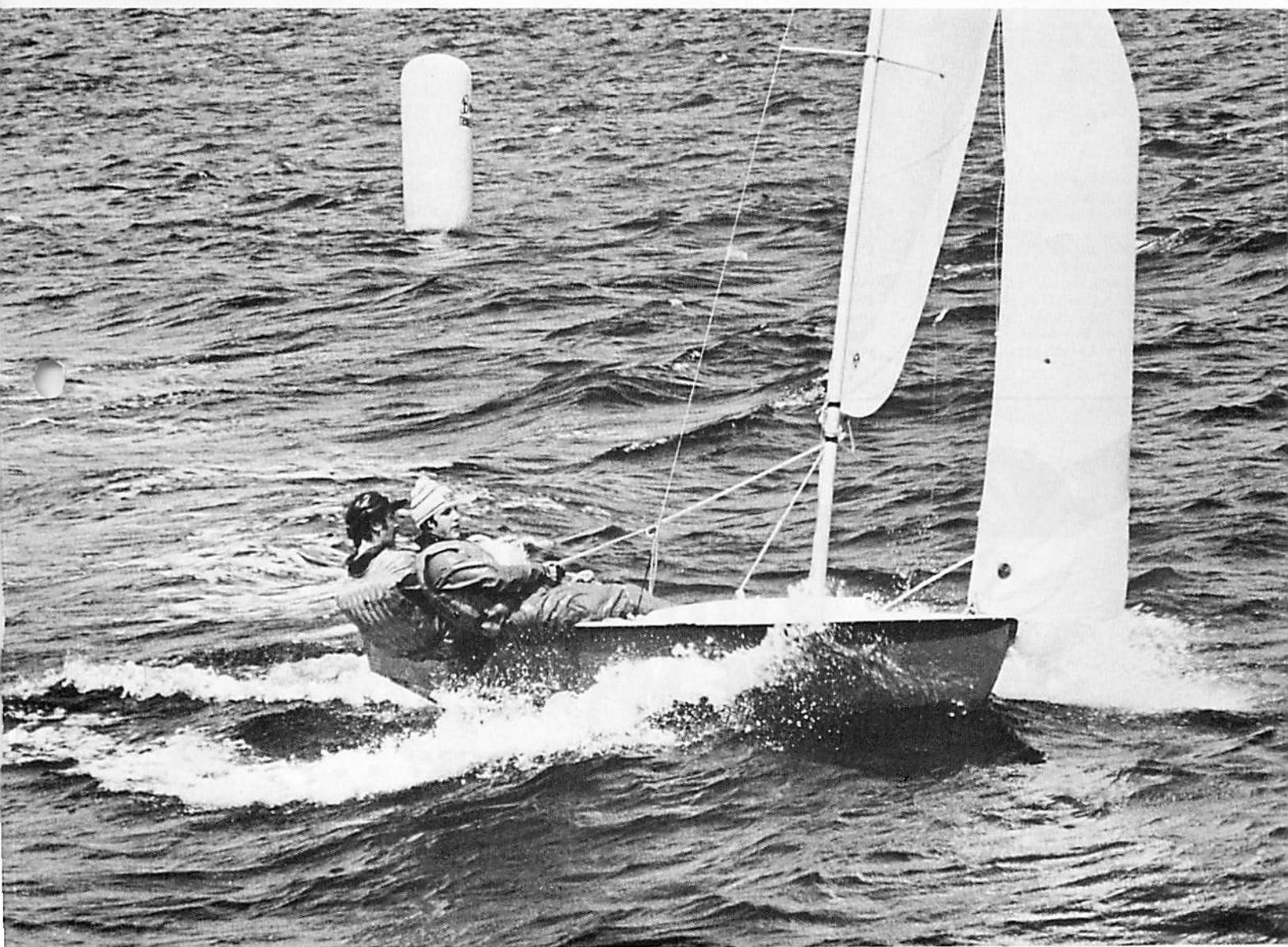

MARCH 1980

Sam Mollet wins another one

Ohio Open Sailed On Turkeyfoot Lake

1979 SNIPE OHIO OPEN STATE CHAMPIONSHIP A Fleet

Boat	Skipper/Crew	Club	Places	Points	Finish
23624	Sam Mollet/Alice	Portage Lakes	3-1-2	8.7	1
19059	Jerry Thompson/Brad	Lake Angelus	1-5-3	15.2	2
20562	Dick Hand/Martha Rizert	Portage Lakes	6-4-1	19.7	3
19793	Lucius Bugbee/Liz	Cuba Lake	4-3-5	23.7	4
21792	Richard Cordell/Jodie	Portage Lakes	5-2-6	24.7	5
19062	Mike Zalzal/Cheryl	Cowan	2-8-4	25.0	6
19393	Leo Murphy/Joe	Cuba Lake	7-6-8	38.7	7
23663	Skip Remter/Buffy Wiodska	Detroit River	10-7-7	42.0	8
19719	Philip Tanski/Laura	Chippewa	8-9-10	45.0	9
18320	Henry Young/Steve Hunter	Portage Lakes	9-10-9	46.0	10
21104	Bill Durbin/Mike Lynch	Portage Lakes	11-dns-dns	51.0	11

B Fleet

Boat	Skipper/Crew	Club	Places	Points	Finish
22350	Erik Witt/Manfred	Indianapolis	1-1-6	11.7	1
16697	Roger Hicks/Kim	Chippewa	4-2-4	19.0	2
18629	Tom Dillingham/B. Fraser	Portage Lakes	2-4-5	21.0	3
9291	William Bees/Cecelia	Chippewa	3-5-3	21.4	4
18627	Vincent Johnson/Bonnie	Portage Lakes	5-6-2	24.7	5
20633	Ted Kersker/Ted Johnson	Portage Lakes	8-7-1	27.6	6
22287	Ken Parke/Jim Herndon	Portage Lakes	6-3-7	30.4	7
16401	Ron Hontert/Elaine Doherty	Portage Lakes	7-8-dnf	41.0	8
16730	Dave Raynor/Jessie	Portage Lakes	dns-dns-dns	45.0	9
13456	Ben Ansley/Maxine	Portage Lakes	dns-dns-dns	45.0	10

The 1979 Snipe Ohio Open State Championship Regatta was hosted by the Portage Lakes Yacht Club September 22-23 on Turkeyfoot Lake at Akron, Ohio. Twenty one Snipes from Ohio, Indiana, Michigan and New York competed.

The winning skipper was Sam Mollet of the host fleet with his wife, Alice, as crew. Sam had previously won in 1979 the Bermuda, New York State and Annapolis regattas. Jerry Thompson finished in second place with Dick Hand, Lucius Bugbee and Dick Cordell taking third, fourth and fifth places.

The "B" Fleet part of the Regatta was won by Eric Witt, of Indianapolis, with his father, Manfred Witt, as crew. He was followed by Roger Hicks, Tom Dillingham, Bill Bees and Vince Johnson who finished second through fifth places. Eric also won the best junior skipper award.

Two races were sailed on Saturday, the first day, on a triangular course with good but puffy winds of 15-18 knots. Life jackets were required by the Race Committee.

In the first race Thompson led at the first mark closely followed by Bugbee and Mollet. Positions in the race often changed, with Bugbee taking the lead in the second lap and Mollet leading for part of the third. Thompson finally won on

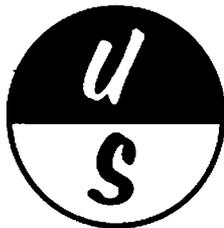

Ullman Sails

WIN THE WORLDS!!!

**What more can we say? . . .
How about . . .**

THE NORTH AMERICANS — 1, 2

THE U.S. NATIONALS

Heinzerling — 1, 3, 4 Jr. Nationals — 1, 2, 3
Crosby — 1, 2 Wells — 1, 2, 3

BE A WINNER IN '80 — BUY ULLMAN

Write or call us at 410 29th St., Newport Beach, CA 92663
(714) 675-6970 — Ask about our winter fleet discounts

the last leg with Mollet and Bugbee taking second and third as Mollet was trying to cover both Thompson and Bugbee.

The fresh, puffy, winds continued in the second race. Mollet and Cordell were first and second at the first mark and they never lost their lead. Bugbee moved from deep in the fleet after the first mark to take third place.

At the end of the first day, the standings showed that Mollet was leading the regatta closely followed by Thompson, Bugbee and Cordell.

The third and last race was held on Sunday in brisk, variable, and shifty winds of 8-12 knots. Thompson jumped to a good lead but lost it on the downwind leg when he went low to follow the wind on the rumb line and the rest of the fleet went high on a broad reach.

For the rest of the race it was Hand and Mollet, with Hand winning, Mollet placing second and Thompson moving back up through the fleet to take third.

Trophies were handmade wire sculptures of a Snipe mounted on walnut bases. Evening dinner was followed by a presentation of a home movie of a previous 1975 Snipe Ohio Open, with Dick Hand, Regatta Chairman, as Master of Ceremonies.

Although the number of yachts participating was not large, as many regattas go, the competition was close and the winds were good, variable and foxy. The Regatta was enjoyed by competitors and guests alike with good fellowship and no protest.

Henry Young



A Fleet and B Champion: Front - Alice Mollet, Manfred Witt, Kim Tompson, Martha Rizert, Liz & Elizabeth Bugbee and Jody Cordel. Back: Sam Mollet, Eric Witt, Jerry Thompson, Dick Hand, Lucius Bugbee and Dick Cordell.



B Fleet - L to R: Front row: Manfred Witt, Kim Hicks, B. Fraser, Cece Bees, Bonnie Johnson, Back row: Eric Witt, Roger Hicks, Tom Dillingham, Bill Bees and Vince Johnson.

District V Regattas — 1980

Lake Ontario Open (Briody Cup),
Cuba Lake Y.C. — June 28-29,
Leo Murphy, 107 N. Clinton St.,
Olean, NY 14760

New York State Open, Chautauqua
Lake Y.C. — June 21-22,
Les Larson, 10 Winding Way,
Lakewood, NY 14750

District V Championship, Newport
Y.C., Rochester — Jrs. July 11, Srs.
July 12-13
Charles Webster, 10 Whippletree
Rd., Fairport, NY 14450

Champagne Regatta — Finger Lakes
Wine Museum Trophy, Keuka Lake
Y.C. — Sept. 20-21
Graham Hoffman, 5738 Co. Rd.
33, RFD 3, Canadaigua, NY 14429

**SUPPORT YOUR
BULLETIN ADVERTISERS!**



FULL DECK TRAILING & MOORING COVER

(3 photos above)
• Can be trailed or used with mast up • Extra reinforcement at all stress points • 5/16" elastic shock cord in hem under rubrail • Heavy duty nylon zipper • Loops for under hull straps

Coated NYLON or 13 oz. CANVAS \$115.00 ppd.

Bainbridge YACHTCRILLIC \$126.00 ppd.

FOOTBALL SHAPE COCKPIT BAG \$7.00 ppd.
• Hangs tied into cockpit, zips closed, clear see-through panel

Satisfaction
Guaranteed
Send check to:

THE SAILORS' TAILOR
191 Bellecrest, Bellbrook, OH 45305
Bob Rowland 513-848-4016

3 COVERS IN 1



**IN STOCK FOR
IMMEDIATE DELIVERY!**



BOTTOM COVER \$112.00 ppd.

• Flannel lined waterproof grey canvas with drainhole
• Fits with shock cord in hem that clings to deck

DAGGERBOARD COVER \$19.00 ppd.

• Flannel lined canvas • Specify size & shape

RUDDER COVER \$14.00 ppd.

• Flannel lined canvas • No zippers or snaps to scratch rudder

OR see us in
Snipe #23333

SNIFE BULLETIN

(USPS 611-500)

SNIFE CLASS

INTERNATIONAL RACING
ASSOCIATION

MARCH 1980
Vol. XXIX No. 3

S.C.I.R.A. OFFICERS

Commodore

Gonzalo E. Diaz
2825 S.W. 92 Place
Miami, Florida 33165

Vice Commodore

Paul F. Festersen
Suite 510
Service Life Building
Omaha, Nebraska 68102

Rear Commodore

Arturo Delgado
Puerto Rico, 6
Madrid 16, Spain

Executive Secretary and Treasurer

Lowry Lamb
Privateer Road
Hixson, Tenn. 37343

RULES COMMITTEE

Chairman: TED A. WELLS
5 Huntington Ave.
Wichita, Kansas 67208

EDITOR

Lowry Lamb

EDITORIAL & BUSINESS OFFICE

Address all correspondence to:
Privateer Road, Hixson, Tennessee
37343, U.S.A.

PUBLICATION INFORMATION

Published monthly by Snipe Class
International Racing Association, In-
corporated, (not for profit).
Forms close on the 1st of the month
preceding publication. Material re-
ceived after that date will not appear
until later month.

Printed in the U.S.A. at Chattanooga,
Tennessee. Second-class postage paid
at Hixson, Tennessee and at addi-
tional mailing offices.

ADVERTISING

Contract rates furnished upon appli-
cation.

SUBSCRIPTION

\$5.00 per year. \$5.00 of the amount
of dues in SCIRA are paid for a year's
subscription to the SNIFE BULLE-
TIN.

CHANGE OF ADDRESS

Notify Snipe BULLETIN of any
changes, both old and new addresses
complete with zip code. Allow a
month to become effective.

THE COMMODORE SAYS

Buzz Lamb and I have been corre-
sponding about the need of introducing
the Snipe in Venezuela in time for the
next Pan American Games in 1983.

We heard that Lorenzo Depascale was
moving to Venezuela but we do not have
his address yet. On the other hand I had
a meeting here in Miami a few days ago
with Mr. José Cristobal Rodriguez who

along with Jaime Osset are getting ready
to build Snipes in Venezuela. The boat
they are going to build is the Bruma
Snipe.

There is another good Snipe sailor in
Venezuela, Serafin Arrojo, that I have not
been able to contact. He is working in
Caracas for Supermercados Cada.

Chuck Loomis reported that Venezuela
planned to have all new Snipes for the
Pan American Games and that everybody
would have to sail the same type of boat
rather than bringing their own. That sure
sounds good!

Gonzalo E. Diaz
SCIRA Commodore

THOUGHTS WHILE SAILING

We recently received a letter from Past
Commodore Svend Rantil. He is now re-
tired and spends his time "messaging around
in boats." He had some nice sentiments
that we thought all Snipe members would
like to read:

"We are listening to the news every
day and hope that the political situation
can be solved without having a war, which
nobody knows when it will stop, and how
big it will be. Thinking of how easy
SCIRA actually could solve their interna-
tional problems, it is a shame that it is
not possible for ordinary people to do the
same. But, of course, they are not sailors,
and have not been in the Snipe Class.
They must have been to another, not-so-
fine school where they do not educate
people so well as in the Snipe Class."

We share his opinion.

Fighting Inflation

Inflation is everywhere. To keep it out
of SCIRA dues — unlike everything else,
they haven't gone up in the last couple of
years — there is only one solution; pay
YOUR dues.

Dues collection, which goes from Jan-
uary to December every year, is complica-
ted by Snipers who don't pay.

Dues are due now. Send \$15.00 to the
SCIRA office, or pay through your fleet
captain. Collect from fleet members who
forgot to pay last year. The skipper who
doesn't pay his fair share of the Class
expenses has his hand in YOUR pocket.

LATE DEVELOPMENTS:

An acting national secretary for Vene-
zuela has been appointed. He is: Jaime
Osset, Colinas da la California, Calle
Tequeteque, Residencias Monterrey, Torre
B, Apartamento 9-B, Caracas, Venezuela.
Anyone with contacts in Venezuela is
urged to help with the formation of the
new fleet.

THE COVER

The winds of March? No, England's
second team at the World Championship,
Paul Mason and Kevin Harvey, practice
heavy weather technique on Sydney Har-
bor last August. Photo by Per and Inga
Gothlin.

THE SCORE

The new year has gotten off to a good
start with 56 numbers being issued in the
first month. Spain got 21 followed by the
U.S.A. with 20. Finland took 10, England
2, Dominican Republic 2 and Portugal 1.
No new fleets were chartered.

Numbered SNIPES — 24153
Chartered Fleets — 760

What do you expect from your sailmaker?

service . . .

For Shore Sails service is as important as winning itself. We'll be at as many regattas as possible, not just the large championships, anxious to help improve your boat's performance. We'll answer any questions you may have and sail with you if you like. We're Snipe sailors too, and you'll feel that in just the little extra effort to make sure you're satisfied with your new Shore sails.

quality . . .

For Shore Sails quality means a check system for seam smoothness, batten pockets, boltroping and grommets. It means each sail is cut from exact mylar patterns so that not only are they smooth, but they are identical to one another. It means choosing only the finest quality cloth, especially for Snipe sails. To you it means you no longer have to worry about anything but winning races.

performance . . .

SHORE SAILS WERE 3rd AND 4th AT THE 1979 NORTH AMERICANS. FOUR OF THE TOP EIGHT USED SHORE SAILS EXCLUSIVELY . . . MORE THAN ANY OTHER SAILMAKER!

Join the Shore team. We're anxious to become your personal sailmaker

Call or write
Greg or Patti Fisher
or look for us
on the
regatta circuit.



SHORE SAILS

330 West Spring Street
Columbus, Ohio 43215
(614) 221-2410

7 Merton St.
Newport, R.I. 02840
(401) 849-7997

Ohio Snipe Sailors Offer Mast Deflection Test Results

Three-year data search reveals comparison of mast types

By Bob Forsman, Dick Hand
And Sam Mollet, PLYC Fleet 110

These Snipe mast static deflection tests were conducted between 1976 and 1979. Results were converted to millimeters for ease of comparison. The apparatus and test description remains feet and inches.

Bob, Dick, and Sam request that results of any similar deflection tests for masts they have not tested: newer Cobra II with solid aluminum colored web, Proctor Alpha minus, Proctor Alpha plus, Needlespar, Bryant, and others, old and new, be sent directly to them, or to the

SCIRA office for forwarding to them.

They leave interpretation of the deflection data to others, along with questions about stiff mast vs bendy mast, low bend, tip bend, sidebend vs aft bend, loose rig vs tight rig etc. Perhaps someone will simplify it all in a handy table form for wind and sea conditions.

(For description of effect of mast bend characteristics on sail shape and performance see the December 1979 issue of Yacht Racing and Cruising.)

OBJECT: Statically Load Different Snipe

Mast Types to Measure Deflection Amounts.

APPARATUS & TEST:

TEST IA – Mast Fore & Aft Deflection: A 50 lb. weight is suspended from each mast at a point 8'-6" from bottom of top mast band (approximately ½ distance between bands) while the mast is supported by saw horses at the top band and at a point 20'-1" below bottom edge of top band.

A small diameter reference string is tightly drawn between two nails (one on

Mast No.	Mast Type and Year	Fore & Aft Deflection – (mm) Test IA Measurement Locations						Test IIA Locations		Side Deflection – (mm) Test IB Measurement Locations						Test IIB Locations	
		1	2	3	4	5	6	T	M	1	2	3	4	5	6	T	M
1	Cobra I 1972	43	70	81	73	52	22	94	16	52	87	100	97	71	29	111	24
2	Cobra I 1972	38	67	76	67	44	22	83	14	51	89	103	95	69	29	106	24
3	Cobra I 1973	46	76	89	79	56	22	N/A		56	90	106	100	68	27	N/A	
4	Eichenlaub 1976	41	67	78	73	51	22	94	17	54	90	110	100	75	35	117	25
5	Eichenlaub 1976	44	71	83	49	54	25	N/A		56	95	110	100	73	32	N/A	
6	Proctor E 1967	29	62	75	70	51	22	N/A		51	89	106	92	70	32	N/A	
7	Proctor E (Similar to No. 6)	29	64	78	70	51	24	76	17	49	86	102	95	68	21	105	25
8	Proctor EX 1968	37	62	76	70	51	24	N/A		49	86	103	95	70	30	N/A	
9	Proctor EX 1969	32	60	70	64	46	21	N/A		48	75	90	84	60	25	N/A	
10	Bruder 1976	48	75	90	84	62	25	N/A		95	167	200	186	135	60	N/A	
11	Wooden 1965	44	76	89	83	60	27	N/A		37	68	81	75	54	25	N/A	
12	Proctor Alpha + Double Taper 1979	43	72	86	79	57	25	85	21	61	107	129	120	86	36	128	34
13	Cobra II Solid Gold Web 1977	65	103	118	107	76	40	140	27	88	146	169	151	110	54	187	45
14	Eichenlaub 1977-No Taper	33	57	68	68	51	24	73		48	86	103	94	68	32	110	

each saw horse). Measurement locations 1, 2, 3, 4, 5, and 6 from bottom of the top band spaced 3 feet apart are inked onto reference string.

Measurements from the top (i.e., back sail groove side) of the mast to the string are recorded for each measurement location, first with the 50 lb. weight suspended from the mast being tested (i.e., measurement L) and then without the 50 lb. weight (i.e., measurement U).

The mast deflections (D) at each measurement point are then determined by subtracting the smaller measured dimension U from the larger measured dimension L.

TEST IB – Mast Side Deflection: This test is the same as above Test IA except the mast is rotated 90 degrees and measurements from top (now side of mast) to reference string are measured, etc.

TEST IIA – Mast Tip Fore & Aft Deflection: A 50 lb. weight is suspended from the mast at the second band from the mast top and a second 23 lb. weight is suspended from the second band at the bottom of the mast while the mast is supported by two saw horses located, one located 5'-7" from bottom of top band (approximate sidestay/forestay intersec-

tion points) and the second saw horse located at the lower edge of the lower top band.

A small diameter reference string is tightly drawn between two nails (one on each saw horse). Measurement location M is inked onto string 11'-2 3/4" from lower edge of top mast band (approximately one half distance between sidestay/forestay intersection points and lower top band). Also a reference block is placed on ground under top mast band centerline for measurement location T.

Measurement from the top (i.e., back sail groove side down) of the mast to the ground reference block at location T and from the reference string to the top of mast at location M, first with the 50 lb. weight suspended from the mast (i.e., measurement L) and then without the 50 lb. weight (i.e., measurement U). The deflection at each point is determined by subtracting the smaller measured dimension L from the larger measured dimension U.

TEST IIB – Mast Tip Side Deflection: This test is the same as the above Test IIB except the mast is rotated 90 degrees and measurements from top (now side of mast) to reference string/block are measured, etc.

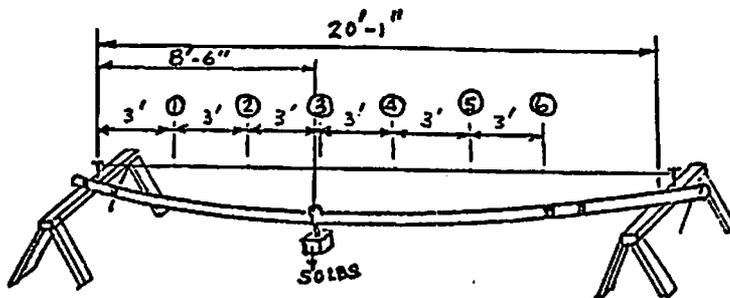

Test IB – Mast Side Deflection

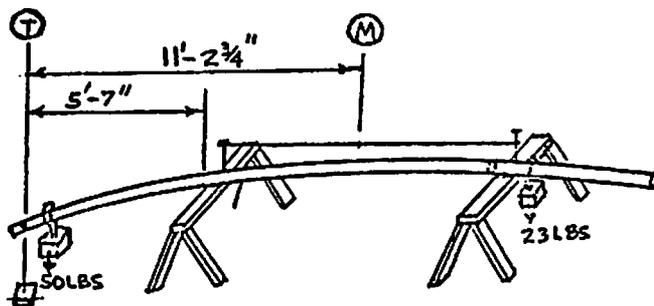

Test IIA & IIB – Mast Tip Deflections (Not to Scale)

NOW! PRINCIPAL SAILING RULES OF NAYRU GRAPHICALLY INTERPRETED

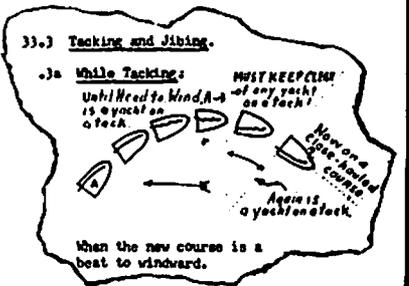

This 15th edition by Fearon D. Moore contains 16 pages of diagrams and explanations of the racing rules. It gives you the basics for 99% of the situations. Send 60c for a single copy or \$7.50 for 20 copies. Include another \$3.00 for the official IYRU-USYRU Rule book, if wanted.

FOR SALE ONLY BY

SCIRA

Privateer Road, Hixson, TN. 37343



Snipe Building Plans

BLUEPRINTS – \$10.00

Revised January 1976

SCIRA

Privateer Road, Hixson, TN 37343

SUPPORT YOUR SNIPE ADVERTISERS

Basic Snipe Sailing Manual

Intended for beginning Sniper, crew, and wives, this excellent manual (6" x 9") is a glossary of nautical terms with a sketch applicable to Snipe; knots with illustrations; handling the boat; tacking; running; reaching; jibing; heave-to; capsize; all simplified rules; thumb nail tactics; check list; important Snipe measurements. A most valuable handbook – still not complicated. \$1.00 per copy – \$8.00 for 10. From SCIRA only.

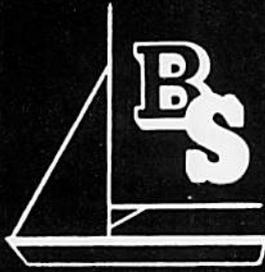

BRYANT SPARS

222 Central Avenue
Buffalo, New York 14206
(716) 893-1100

Look for this in your new spar "THE DIFFERENCE"

Dear Snipe Sailors,

During the past five years Bryant Spars has taken on many large challenges. We've entered two large one-design classes with our spar with a limited amount of research. In those two classes we achieved the status of a high-quality spar builder that is depended on.

In the fall of 1978 we decided to take on our largest challenge and start a Snipe spar from scratch. We looked at many Snipe spars on the market. With all the information we accumulated, the Bryant Spars staff discussed what to do. The results of those conversations is the CAB No. 1. This spar is a combination with a section of 2.49" x 1.94", a constant wall thickness of 0.96 with a side to side taper of 81" from the top.

We gathered together an assortment of mainsails and looked at how they fit our spar. What a surprise we had, that little or no adjustments had to be made to the sail. To you that means your sail should easily adapt to the CAB No. 1. The Bryant Spars staff has available upon request deflections of the CAB No. 1 compared to two spars currently on the market. We've also taken the courtesy of having these deflections available to a variety of Snipe sailmakers for your convenience.

If you have any questions, please call or write Mark Bryant or Andy Fox for more information about the CAB No. 1.

LOOK IN THE BULLETIN FOR MORE INFORMATION TO COME
"THINK SPEED"

Sincerely yours,

Mark Bryant

Wind Gives Up Ghost At Halloween Regatta

No matter what, Hallowe'en Regatta is always special. It is a time to renew friendships, to relax and enjoy sailing, to party too much, to look back over a season of achievements and failures, to remember the funny and the dumb, the gales and the holes, the disasters averted and those not. For 26 years each Hallowe'en has been different in details, but the overriding impression is always: "This is why we're Snipers."

As this is an article to report sailing results, I guess I must mention the racing, but goodness knows there was little enough of that possible for Hallowe'en 1979. Saturday morning dawned clear, warm, and very flat, as the twelve juniors set out for their race.

Our major reason for having a separate junior race is to allow those kids who have no Snipe — or whose parents won't drag two boats — to get a chance to skipper. The value of this was clearly shown as Kevin Guido, who's learned all he knows as crew for the old Master Francis Seavy, managed a clear victory over Marc and Anne Duvoisin who've dominated D-4 juniors for the last few years. (*Ed Note: Who learned all they know from their father Pete, who learned all he knows from when he was a kid crewing for Francis Seavy.*)

Saturday afternoon saw even lighter "winds" as 90 Snipers drifted around two short courses. There was plenty of time to admire the gorgeous fall colors mirrored in the lake, and if you weren't trying to win, it was a lovely afternoon.

Saturday night Matt and Karen Gregory — who claim PYC as their club but whom AYC claims, as we raised them — had most to celebrate as their 2-1 finishes gave them a nice lead over PYC's Bill



Privateer's Matt Gregory, winner along with his sister Karen, of his second Hallowe'en Championship.

Simons with 1 - 6. In the Goblin Division AYC's Bill Hooper and his daughter Cindy had a 5 point lead over PYC's Rob Fowler. After dinner, disco dancing finished off the evening — and most of the participants!

Sunday morning the wind was worse — so there must have been some Saturday after all. A long windward-leeward-windward course saw nearly everyone with a moment of great hope as small fingers of wind picked up first this boat, then that

group, then this one . . . Nonetheless the good skippers won. Matt held on, Greg worked up, and Pete was consistent as ever. In the Goblins, Bill Hooper really cranked it up and Means Davis V had his first moment of glory.

Lunch, hot buttered rum in those now famous mugs, and the arrival of a very nice breeze preceded trophy presentation. Another Hallowe'en is history.

Peggy Davis
AYC Fleet 330

1979 HALLOWEEN REGATTA SPOOK DIVISION — A FLEET (Top 20 of 55 entries)

Boat	Skipper	Club	Places	Points	Finish
21021	Matt Gregory	PYC	2-1-3	8.7	1
23619	Greg Fisher	Columbus,OH	1-7-1	13	2
19091	Pete Duvoisin	PYC	4-3-3	19.4	3
20953	Marc Duvoisin	PYC	2-8-2	20	4
20221	Steve Sudduth	Jacksonville	12-2-2	24	5
19020	Bill Simons	PYC	1-6-9	26.7	6
16104	John Muhlhausen	AYC	3-7-6	30.4	7
21548	John Sinclair	AYC	14-2-4	31	8
20897	John McGowan	Jackson, MS	11-3-5	32.7	9
6995	Francis Seavy	Clearwater	4-9-7	36	10
23423	John Walton	Southfield, MI	6-20-1	37.7	11
19747	Dan Williams	PYC	8-11-4	39	12
23978	Andy Fox	Buffalo, NY	22-1-6	39.7	13
19924	Ken Simons	PYC	3-5-17	39.7	14
17735	Buzz Lamb	PYC	14-4-7	41	15
23036	Bill Snowden	AYC	9-5-10	41	16
19255	Bob Reese	PYC	10-10-5	42	17
23456	Means Davis	AYC	6-6-13	42.4	18
20196	John O'Donnell	AYC	10-8-15	51	19
21508	Fred Bradshaw	AYC	7-17-12	54	20

GOBLINS — B FLEET (Top 20 of 36 entries)

Boat	Skipper	Club	Places	Points	Finish
19918	Bill Hooper	AYC	1-5-1	10	1
20645	Means Davis V	AYC	2-11-4	28	2
18022	Rob Fowler	PYC	5-3-8	29.7	3
12021	Cliff Simmons	Bermuda	16-4-2	33	4
21551	Bruce Hudson	BFSC	10-2-11	36	5
21627	Harvey Griffith	AYC	12-1-12	36	6
19916	Lewis Seabrook	Charleston	3-14-6	37.4	7
12441	Ray Stang	BFSC	7-10-5	39	8
18023	David Lark	BFSC	4-7-22	49	9
22468	Erle Bennett	Memphis	11-21-3	49.7	10
22469	Frank Briggs	AYC	6-13-17	53.7	11
20933	Bill Cobb	AYC	20-9-9	56	12
22000	Rick Brookover	Nashville	24-6-15	62.7	13
22358	Tarasa Davis	AYC	17-12-18	65	14
23069	Ed Hiatt	Valdosta	19-15-13	65	15
21550	Walt Jenison	PYC	21-16-10	65	16
23595	Tran Alfrey	Cincinnati	14-8-26	66	17
22562	Jim Hater	Cincinnati	9-19-23	69	18
17131	Ron Frith	Bermuda	29-18-7	72	19
13524	Tut Campbell	Atlanta	8-26-28	80	20

JUNIOR RACE RESULTS

Boat	Skipper	Club	Finish
6995	Kevin Guido	Clearwater	1
20953	Marc Duvoisin	PYC	2
19437	Mark McCord	PYC	3
19225	Robert Reese	PYC	4
18327	Teddy Turner	AYC	5
20645	Means Davis	AYC	6
22358	Tarasa Davis	AYC	7
21612	Jack Amoss	BFSC	8
11900	Andrew White	Annapolis	9
22699	Scott Durbin	Jacksonville	10
21640	Chris Nord	Princeton	11
20884	Chris Hale	BFSC	12

Gene Soltero Takes Briody Memorial Regatta

Newport Yacht Club was the host for this year's Briody Memorial Regatta. We had a crowd of 20 boats. Some of them came from as far as Texas, Tennessee, Michigan and Massachusetts. The wind on the first day was typical of Newport's

west wind — shifty and puffy. Two boats capsized, but they both finished the race.

The first race was won by Gene Soltero, who came from Texas to warm up for the North Americans. The wind lightened up a bit for the afternoon races but

remained shifty. Both of the afternoon races were won by John Walton, who came from Detroit.

The day's sailing was followed by a steak dinner and an evening of making new friends and trading sailing stories.

At about 11:30 Sunday morning Newport's trusty 11:00 thermal came in, bringing a steady north wind. The two races were won by our own Charlie Webster, bringing him within a point of first place. However, Gene proved that his trip was worthwhile by taking first place overall. Fritz Gram took third place, followed by John Walton, who had a bad finish in the last race because he was over early. Fifth place went to Newport's Chuck Fox.

It was a fun weekend for all, which renewed the spirit of friendly competition.

Laura Dahl
Newport Fleet 103

1979 BRIODY REGATTA (Top 10 of 20 entries)

Skipper	Club	Places	Points	Finish
Gene Soltero	Dallas	1-3-3-2-4	22.4	1
Charlie Webster	Newport	3-5-4-1-1	23.7	2
Fritz Gram	Cuba Lake	4-6-2-4-3	36.4	3
John Walton	Crescent	5-1-1-5-15	41	4
Chuck Fox	Newport	2-10-7-3-12	55.7	5
Norm Dahl	Newport	7-2-9-7-10	60	6
John Kelley	Cottage Park	9-4-5-9-13	63.7	7
George Hock	Onondaga	9-11-16-18-2	71	8
Fred Seedhouse	Newport	11-9-12-6-5	71.7	9
Tersh Bugbee	Cuba Lake	8-8-11-15-6	77.7	10

Gonzo Diaz cops second place trophy

Colyer Overpowers Rivals At Comodoro Rasco Event

Past SCIRA Commodore Bruce Colyer and crew Glenn Sutter won the 1980 Comodoro Rasco Regatta with 1-1-2-(4), scoring only 3 Olympic points; consequently, they had to drink most of "LA BOMBA" while we all sang, a tradition now in this Regatta.

Second was Gonzo Diaz Jr. with crew Ron Russell and third was Bob Russell having a Naval Academy sailing team buddy as crew (tough guys to beat, ask the Old Man!!).

Race Committee headed by Dick and Sally Russell got three races on Saturday afternoon with winds from the Northwest 15 to 25 mph. Sunday only race was in a 10 to 15 from the North.

Coconut Grove Sailing Club Commodore John Brennan presented trophies to winners including Tom McNally from St. Petersburg who won class B. Commodore Brennan also helped with "LA BOMBA" both drinking and singing!

XI ANNUAL COMODORO MANUEL RASCO REGATTA (Top 10 of 16 entries)

Boat	Skipper/Crew	Club	Places	Points	Finish
24042	Bruce Colyer/Glenn Sutter	CRYC	1-1-2-4	3	1
23711	Gonzo Diaz, Jr./Ron Russell	CGSC	5-4-1-1	8	2
19389	Bob Russell	CGSC	8-2-4-2	14	3
21712	Gonzalo Diaz, Sr./R. Lizano	CGSC	2-5-7-3	18.7	4
22292	Pete Melvin	CRYC	dns-3-3-dq	34.4	5
20816	Gaby Bustamante	CGSC	9-8-6-5	35.7	6
20002	Tom McNally	SPYC	6-11-5-8	35.7	7
19723	Mike Brown	CGSC	7-10-9-7	41	8
20688	Richie Silverman	CGSC	10-6-8-dns	41.7	9
23037	David Helmick	CRYC	3-7-dnf-dns	41.7	10

Boat X-Change

All are fully rigged — Some have lots of extras — CALL NOW!

Boat No.	Builder	Material	Trailer	Sails	Location	Price	Phone
15944	Lofland	Glass	no	yes	Lincoln, NE	\$1,050	402-473-1404
20685	Chubasco	Glass	no	yes	Long Island, NY	\$2,500	516-676-4186
16167	Lofland	Glass	yes	yes	Moorestown, NJ	\$ 995	609-234-6318
22594	Duplin	Glass	no	yes	Billerica, MA	\$1,550	617-663-6521
21760	Eichenlaub	Glass	yes	yes	Valdosta, GA	\$2,500	912-559-5411
7796	Home	Wood	no	yes	Murrysville, PA		412-325-2138
16821	Lofland	Glass	no		Cincinnati, OH	\$ 950	513-821-6673
18118	Lemke	Glass	no		Cincinnati, OH	\$ 950	513-232-0135
12884	Gerber	Glass/wood	yes	yes	Atlanta, GA	\$1,000	404-955-1492
14380	Lofland	Glass	yes	yes	Atlanta, GA	\$ 900	404-955-1492
23888	Mueller	Glass	yes	yes	Atlanta, GA	\$2,750	404-955-1492
22002	Verwey	Glass	yes	yes	Atlanta, GA	\$1,700	404-955-1492
19337	Call	Glass	yes	yes	Atlanta, GA	\$1,600	404-955-1492
23036	Phoenix	Glass	yes	yes	Atlanta, GA	\$2,700	404-955-1492
7370	Mills	Wood	yes	yes	Fernandina, FL	\$ 800	904-261-3165
14632	Lofland	Glass	yes		Topeka, KS	\$ 800	913-272-0363
23622	McLaughlin	Glass	yes	yes	Ontario, CAN	\$3,500	519-434-7500
21800	Mueller	Glass	yes	yes	Ontario, CAN	\$1,800	519-434-7500
16182	Home	Glass/ply	yes	yes	Ontario, CAN	\$1,000	519-434-7500
16182	Home	Glass/ply	no	yes	Ontario, CAN	\$ 800	519-434-7500
18015	Chubasco	Glass	no	yes	Chattanooga, TN	\$1,700	615-875-5940
10224	Home	Wood	yes	yes	Waterbury, CT	\$ 900	203-573-8346
23620	McLaughlin	Glass			Springfield, IL		217-529-4089
17236	Chubasco	Glass/wd deck	yes	yes	Oldsmar, FL	\$1,700	813-784-9668
22289	Cyclone	Glass	yes	yes	San Diego, CA	\$3,000	714-582-3317



**SUPPORT YOUR
SNIPE CLASS**



Briody Regatta trophy winners. Skippers in back row, left to right: G. Soltero, C. Webster, F. Gram, J. Walton, C. Fox. Crews in front row: J. Soltero, P. Webster, M. Flynn, H. Fox. (Photo by K. Morton)



Caught in the act. Picture taken at the starting gun shows four boats over early: Dahl, Gram, Soltero and Walton. The committee boat marking the other end of the line is even with the bow of 16699. (Photo by P. Dahl)



Retzhaupt trophy winners, left to right: L. Bugbee, J. Kroeger, F. Gram, G. Hock, T. Whitmeyer. (Photo by P. Dahl)

FAST SNIPES FROM



PHOENIX BOAT CO.

1556 W. 11th Street Long Beach, Ca. 90813
(213) 432-2093

Don't forget to send the Bulletin a complete report and photos on your Snipe regatta. In the overall results be sure to include names of skipper and crew, home club or fleet, places in each race, total points, and standing in fleet.

Scientific Sailboat Racing

Thoroughly revised and updated by Ted Wells and Lowry Lamb. Illustrated with diagrams and photographs. Since it was first published in 1950 and through one revision in 1958, *Scientific Sailboat Racing* has established itself as a classic of its kind for small-boat sailors. Now, it has been thoroughly overhauled to take advantage of the latest developments, particularly in equipment, that have come about in the last twenty years of sailboat design and handling.

From any book store or direct from SCIRA — \$10.95

DODD, MEAD & CO
79 Madison Avenue
New York, N.Y. 10016



A Fleet Winners – In order of finish, left to right (crews kneeling): Henry Davis/Leslie Tucker, Martin Bebb/Amy Person, Doug/Alane Day, Paul/Sig Festersen, Bruce/Irene Hurst, Rick/Tom O'Brien. (Photo by Jackie Stroud)



B Fleet Winners – In order of finish, left to right: Steve Kersey/Ona Festersen, Jack Vermillion/Tim Towle, Phil/Connie Eberhart, Bob/Patsy Congrove. (Photo by Jackie Stroud)

Henry Davis Shines At Sunflower Regatta

The Shawnee Snipe fleet, Topeka, Kansas, held its annual Sunflower regatta, August 25 and 26, under the organization of Rex Tucker, Regatta Chairman, and Tim Edwards, Fleet Captain. In spite of the gasoline shortages, 29 boats competed in the A Fleet and 14 in the B Fleet.

Henry Davis, Omaha, with Leslie Tucker, Topeka, crewing, sailed his brand new 24100 to first-place in the A Fleet for the four-race series. The three Saturday races were sailed in light to medium air with Henry Davis winning the first one; Martin Bebb, Muskogee, the second; and Doug Day, Lake Lotawana, the third.

One of two scheduled Sunday morning races had to be canceled because of a vicious wind and rain storm. When it passed, we had the best air of the weekend and bright Kansas sunshine for the fourth race. The first place finish in it was a duel expertly fought by Paul Festersen, Omaha, and George Croasdale, Lake Weatherby, with Croasdale crossing the line first by inches.

Handsome Snipe silhouette shadow boxes, designed by Shawnee Snipe sailor, Rob James, went to the captains and crews of the top six teams in the A Fleet: Henry Davis/Leslie Tucker, 1st; Martin Bebb/Amy Person, 2nd; Doug/Alane Day, 3rd; Paul/Sig Festersen, 4th; Bruce/Irene Hurst, Tulsa, 5th; and Rick/Tom O'Brien, Council Bluffs, 6th.

The four trophy winners in the B Fleet were: Steve Kersey, Wichita/Ona Festersen, Omaha, 1st; Jack Vermillion/Tim Towle, Topeka, 2nd; Phil/Connie Eberhart, Omaha, 3rd; and Bob/Patsy Congrove, Topeka, 4th. Steve Kersey swept the B Fleet series with a perfect score — four firsts. Kersey, with David Pierce

SUNFLOWER REGATTA					
A FLEET					
(Top 15 of 29 entries)					
Boat	Skipper/Crew	Club	Places	Points	Finish
24100	Henry Davis/Leslie Tucker	INSA	1-6-2-4	22.7	1
20013	Martin Bebb/Amy Person	Sequoyah	4-1-5-8	32	2
23757	Douglas/Alane Day	Lake Lotawana	5-5-1-9	35	3
20875	Paul/Sigrid Festersen	INSA	8-4-9-2	40	4
17151	Bruce/Irene Hurst	Sequoyah	2-3-8-13	41.7	5
20650	Rick/Tom O'Brien	INSA	21-2-4-3	43.7	6
23755	George/Tracy Croasdale	Weatherby	17-7-6-1	47.7	7
22522	Dick/Nancy Goppert	Lake Lotawana	12-8-3-10	53.7	8
22327	Doug/Rita Goppert	Lake Lotawana	9-11-21-5	69	9
19585	Mary Ann Rix/DeAnn Pierce	Wichita	11-14-7-16	72	10
20500	Hans Hagen/Jack Boene	Weatherby	16-17-10-12	79	11
21553	David/Rita Ryan	Shawnee	18-10-22-6	79.7	12
19283	Steve/Mary Snider		22-13-17-7	83	13
21803	John/Joyce Maultsby	Quivira	19-12-12-17	84	14
21097	Phil/Lona Morse	Shawnee	20-15-11-15	85	15

B FLEET					
(Top 8 of 14 entries)					
Boat	Skipper/Crew	Club	Places	Points	Finish
19910	Steve Kersey/Ona Festersen	Wichita	1-1-1-1	0	1
21095	Jack Vermillion/Tim Towle	Shawnee	5-2-6-2	26	2
18444	Phil/Connie Eberhart	INSA	3-4-4-6	31.7	3
21505	Bob/Patsy Congrove	Shawnee	2-10-2-5	32	4
18838	Bob/Dave Larson	Lincoln	4-8-5-4	36	5
14632	Tim Edwards/Diana Stanley	Shawnee	9-9-7-3	47.4	6
21092	Ray Cooley/Smith	Shawnee	12-5-8-7	53	7
13672	Delmar Tucking/Shirley Abney	Shawnee	7-7-10-8	55	8

Crewing, used the eight-boat Junior race Saturday morning as a tune-up by winning first place in it also. Second and third place winners in the Junior race were: Jamie Rix/DeAnn Pierce, Wichita, and Kevin Ruff, Omaha/Rob James, Shawnee.

Saturday's races were capped with the traditional Kansas steak fry at the lake club house with entertainment by the Rip Chords, a barbershop quartet, which includes two members of the Shawnee Snipe fleet, Bill Hamm and Herschel Stroud. The afterglow party, held graciously by Jerry and Ann Palmer in their home, featured Paul and Sig Festersen relating their experiences at the World's

in Nova Scotia, and Henry Davis confiding with the other sailors about his classic use of the compass — not on the lake, but on the highway when he was lost. He stopped his car, walked back to his Snipe, and checked the compass to find out which way was North. It worked.

*Herschel Stroud
Snipe Fleet 597*



Mary Ann Rix, Wichita's fast lady skipper, maneuvering her boat, "Hot Flashes", at the start.



Above: Steve Kersey and Ona Festersen happy with a perfect score – four firsts. Below: A new boat brings out admirers Herschel Stroud and Doug Day even in the rain.



Bruce and Irene Hurst flat and cruising. (Photos by Jackie Stroud)

PHOENIX FIRESTIX



Black Anodized

- Small Diameter Mast
- Octagon Boom Section

PHOENIX BOAT CO.
1556 W. 11th Street
Long Beach, Ca. 90813
(213) 432-2093

CLASSIFIED

Classified ad rates ten cents a word. Minimum charge \$3.00. Ads accepted on a cash basis only. Send remittance for the proper amount.

SCIRA POSTERS Only a few left! 34"x40" on heavy material, these posters are the SCIRA emblem in 5 colors. Every fleet should have one. \$4.75 plus 25 cents handling. SCIRA, Privateer Rd., Hixson, TN 37343.

ACRYLIC SNIPE DRYSAIL COVERS. Yachtacrylic will not rot, mildew, shrink or become brittle. Best cover material available. Outstanding workmanship. No. 1 full deck with 6" skirt for mast up and boom off. Flat type with halyard cockpit lifting bridle. \$99 white, \$103.50 blue. No. 2 Same as No. 1 but has custom looking tapered full skirt for ultimate protection. Zipper at bow for glove like fit. \$139 white, \$144 blue. Shipped UPS ppd. for orders with payment in full. Orders with 50% deposit are shipped balance COD including UPS charge. Contact Chris Rooke @ ROOKE SAILS, 3000 Vantage Dr., Memphis, TN 38131. Phone 901/345-0647.

CHUBASCO 17236, Fiberglass hull, new wood deck, new U/S sails, Cobra mast and boom, Harken blocks, fiberglass rudder, covers and trailer, \$1,700. Gary Muller, 170 Nina Way, Oldsmar, FL 33557. (813) 784-9668.

22289 CYCLONE, one of the last Miami-Built Cyclones. Like new condition, compass, Harkens, 2 suits sails, covers, trailer - \$1,950. Stewart Waugh. Days 800-238-6798. Nights (901) 323-5860.

22815, CHUBASCO. White hull, grey deck, 1st '78 Nationals, end '79 Nationals. Cobra II, North Sails, Richie compass, and all Harken blocks. Many other extras. \$3,000. Mark Reynolds, 2750 Rosecrans St, San Diego, CA 92106 or call DeAnn Wright (714) 582-3317.



We build the fastest Snipes . . . in the world!

6111 Dayton Blvd.
Hixson, Tenn. 37343
(615) 842-4894

MIKE
McLAUGHLIN

REWARD YOUR CREW!

Give gift subscriptions of the BULLETIN to your crew.

PROMOTE SNIPE

Brochures are available to give to prospective Snipe Sailors. Also available in quantity for fleet use. Great for boat shows. Write SCIRA office.

Callison Triumphs In Champagne Competition

Steve Callison, from Severn Sailing Association, took a weekend off from Hobart College and, along with classmate Kathy Bullark, won the lightly attended but thoroughly fantastic Keuka Champagne Regatta.

The regatta was held September 22, 23, 1979, and Keuka Lake was at its finest. The coming of Fall brought the North winds; the whole length of blue water was topped with white caps, and clear skies provided temperatures from the mid thirties in the AM to 65 in PM. Fall colors were starting to put their mark on the hillsides, and the vineyards were ready for harvest.

The fleet had 3 races in planing conditions on Saturday, and 2 races on Sunday in beautiful wind. The boats had numerous fire drills on the screaming reaches of the 7 mile double triangle course. Many comments were heard such as: "I've never sailed so fast."

Steve Callison, superior in the heavy air, won all 3 races Saturday. On Sunday when the wind subsided a bit, he had a

3rd and 2nd to win easily. Graham Hoffman, from KYC, managed 2nd overall, despite tipping over between races on Saturday, the only Snipe capsized of the day. Norm Dahl of Newport was third, and wishes he hadn't been so tired after the second race. A DNS doesn't go well with 3,2,1, and 3. Wolf Goethert, originally from Omaha, now from Rome, NY, had the same problem. He sailed fast (3,2,4) but with a Dns and Dnf finished 4th. George Hock from Onondaga finished fifth. The Hains brothers from Oakville, Canada were 6th overall.

Saturday evening was highlighted by a cocktail party and chicken-steak-corn roast, and all retired early for a 9 AM harbor gun.

An embarrassed regatta chairman (yours truly) explained to Steve that his winning champagne was from California because a big cola company had bought one of our wineries, and they won't give us their past generous allotment. Anyway, congratulations Steve and Kathy.

Next year save the Autumnal equinox time and visit the Finger Lakes of New York. Bring your Snipe to sail at Keuka, and we will supply N.Y.S. wine. (I think!)

*Graham Hoffman
Keuka Fleet 382*

KEUKA CHAMPAGNE REGATTA 1979 (Top 10 of 15 entries)

Boat	Skipper	Club	Places	Points	Finish
19712	Steve Callison	Severn S.A.	1-1-1-3-2	8.7	1
21716	Graham Hoffman	Keuka YC	2-5-3-5-1	28.7	2
22472	Norm Dahl	Newport YC	3-2-dns-1-3	35.4	3
18650	Wolf Goethert	Lake Delta YC	dns-3-dnf-2-4	53.7	4
21458	George Hock	Onondaga YC	4-7-5-8-6	56.7	5
19830	Chris Hains	Oakville YS	8-8-2-7-8	58	6
20444	Bob Wightman	Keuka YC	7-6-dnf-4-5	58.7	7
19175	Bud Booth	Onondaga YC	5-4-4-11-10	59	8
20302	Tom Gougeon	Cowan Lake S.A.	9-9-6-6-7	66.4	9
19450	Bob Buhmaster	Keuka YC	11-10-dnf-10-9	80	10

Throw-out race breaks tie for top position in fleet

Liverpool Fleet Holds Second Annual Open

For the second year running the five always racing Snipes at this north of England club organized a class open meeting with the backing of the club's officers. Although only a one-day event the neighboring Snipe fleet at Budworth came across in strength to boost the turnout figures and take both first and second prize.

Three races were organized for the one day meeting with Gary Lewis in his new Richard Martin Marine boat 23762 taking first position with 3¾ points whilst Mark Townsend, also of Budworth fleet, coming in second at 3¾ points; the difference being in the discard Gary was a point up.

The third boat in was again a Martin

Marine helmed by the builder Richard Martin of Windsford Fleet. Crosby's first Snipe in was Simon Brindle in a British Bryland 21911 whom a few weeks prior had been to Budworth's N/W Snipe Championship and again clocked highest placed Crosby boat.

The Open for 1980 is arranged for October 26th and overseas competition is welcome. Being a one day event one realizes to bring a Snipe from abroad is rather expensive therefore to overcome the problem a letter to the UK National Secretary prior to the date will secure both a Snipe and accommodation.

*J. Broughton
SCIRA UK Sec.*



Sanctioned Snipe Regattas

MARCH 9-11, SCIRA MIDWINTER CHAMPIONSHIP, Clearwater Fleet 46, Francis Seavy, 1840 Stevenson Ave., Clearwater, FL 33515.

MARCH 14-16, DON Q RUM KEG, Miami Fleet 7, Gonzalo Diaz, 2825 S.W. 92 Place, Miami, FL 33165.

MARCH 19-22, BACARDI CUP and GAMBLIN MEMORIAL SERIES, Nassau Fleet 391, Godfrey Kelly, P. O. Box N 1113, Nassau Bahamas.

MARCH 23-26, SOUTH AMERICAN CHAMPIONSHIP, Club Nautico San Isidro, Argentine Fleets, Julio A. Labandeira, Alberdi 415, 1636 Olivos, Buenos Aires, Argentina.

APRIL 1-4, PRINCESS SOFIA TROPHY, Club Maritimo San Antonio de la Playa, c/o Virgilio s/n, C'an Pastilla, Palma de Mallorca, Baleares, Spain.

APRIL 5-7, EUROPEAN CUP OPEN, Club Maritimo San Antonio de la Playa, c/o Virgilio s/n, C'an Pastilla, Palma de Mallorca, Baleares, Spain.

MAY 17-18, REDNECK REGATTA, Magnolia Fleet 604, Zeke Downey, P.O. Box 1970, Jackson, MS 39205.

APRIL 26-27, SNIPE HUNT, Atlanta Barefoot Fleet 726, David Lark, 4455 Shiloh Ct, Kennewick WA 98501.

MAY 10-11, SOUTHERN SNIPE CHAMPIONSHIP, Privateer Fleet 142, Scott Cline, Privateer Rd, Hixson TN 37343.

MAY 17-18, GEORGE E. HOWELL MEMORIAL, Whitewater Valley Fleet 653, Jerry Makela, 221 So 15th, Richmond IN 47374.

JUNE 7-8, RIFF-RAFF, Cowan Lake Fleet 433, John Danks, 1024 Lagorio Ave, Cincinnati, OH 45218.

JUNE 14-15, DISTRICT IV CHAMPIONSHIP, Privateer Fleet 142, Dean Hearn, 4712 Privateer Rd, Hixson, TN 37343.

JUNE 14-15, GOVERNOR'S CUP, Island Bay Fleet 91, Lou Dixon, 12 Bay Ridge, Springfield IL 62707.

JUNE 21-22, NEW YORK STATE OPEN, Chautauqua Fleet 124, Les Larson, 10 Winding Way, Lakewood NY 14750.

JUNE 21-22, WOLVERINE REGATTA, Barton B.C. Fleet 520, John Johns, 1220 W Washington, Ann Arbor, MI 48103.

JUNE 28-29, BRIODY (LAKE ONTARIO OPEN), Cuba Lake Fleet 442, Leo Murphy, 107 Clinton St, Olean, NY 14760.

JUNE 28-29, MICHIGAN STATE OPEN, Grand Rapids Fleet 137, H. Skip Baxter, 111-G Waters Bldg., Grand Rapids, MI 49503.

JULY 11-13, SENIOR DISTRICT III CHAMPIONSHIPS, Green Lake Fleet 129, Andy Zeratsky, Lac Verde Court, Green Lake WI 54941.

JULY 11-13, DISTRICT V JUNIOR and SENIOR CHAMPIONSHIPS, Newport Fleet 103, Charles W. Webster, 10 Whippetree Rd, Fairport NY 14450.

JULY 19-20, JUNIOR DISTRICT III CHAMPIONSHIP, Diamond Lake Fleet 158, Frank Pontious, 1407 Pontiac Rd SE, Grand Rapids, MI 49506.

AUGUST 1-3, OAKVILLE/BERMUDA TEAM RACE, Oakville Fleet 321, Chris Hains, 231 Westdale Rd, Oakville, Ontario, Canada.

AUGUST 2-3, U.S. JUNIOR NATIONAL CHAMPIONSHIP, Carlyle Lake Fleet 705, Ray Szczepanski, 7781 Wooddale, St. Louis, MO 63121.

AUGUST 4-8, U.S. NATIONAL CHAMPIONSHIP, Carlyle Lake Fleet 705, Ray Szczepanski, 7781 Wooddale, St. Louis, MO 63121.

AUGUST 16-23, EUROPEAN CHAMPIONSHIP, Espergaerde Fleet 585, Espergaerde Sejlklub, Strandvejen 167, Postbox 59, 3060 Espergaerde, Denmark.

AUGUST 16-17, ONTARIO OPEN SNIPE CHAMPIONSHIP, Oakville Fleet 321, Chris Hains, 231 Westdale Rd., Oakville, Ontario, Canada.

AUGUST 23-24, EVERGREEN REVITALIZER, Evergreen Fleet 740, Larry Colter, 1203 N. Fell, Bloomington IL 61701.

AUGUST 18-22, CANADIAN NATIONAL CHAMPIONSHIP, Oakville Fleet 321, Chris Hains, 231 Westdale Rd, Oakville, Ontario, Canada.

AUGUST 30-31, ROMSLO'S 30 YEAR JUBILEE, Celebrating 30 years of Snipe sailing for Brynjulf Romslo, SCIRA Norway, Gunnar Kjendlie, Wm. Thranes g. 66 D, Oslo 1, Norway.

SEPTEMBER 6-7, INDIANA OPEN, Indianapolis Fleet 409, Buzz Levinson, 6234 Landborough, Indianapolis IN 46220.

SEPTEMBER 13-14, OAKVILLE ONTARIO - DISTRICT V CHALLENGE TEAM RACE, Keuka Fleet 381, Graham Hoffman, 5738 Co Rd 33, RD 3, Canandaigua NY 14424.

SEPTEMBER 20-21, FINGER LAKES CHAMPAGNE REGATTA, Keuka Fleet 381, Graham Hoffman 5738 Co Rd 33, RD 3, Canandaigua NY 14424.

OCTOBER 4-5, OHIO OPEN/OXFORD INCIDENT-ACCIDENT, Acton Fleet 515, Tran Alfrey, 2258 Shenandoah Dr, Fairfield OH 45014.

DECEMBER 7-14, WESTERN HEMISPHERE CHAMPIONSHIP, Yacht Club Uruguayo Fleet 506, Jose Luis Murguía, Buxareo 1116-301, Montevideo, Uruguay.

Official Pocket Patch



(1/2 actual size)

Red Snipe and white sailboat on light and dark blue background with yellow letters and border. Either on felt or washable cotton twill. Size 3" x 3/4"

SPECIFY MATERIAL when ordering . . . \$2.00

A smaller size 2-1/8" x 2-3/4" for caps, etc., but in twill only \$1.50

Send Payment with Order to

SCIRA

Privateer Road, Hixson, TN. 37343



IT AIN'T EASY, BUT —

**THE SAIL BROKERS,
BACON & ASSOC.
WILL BE MOVED
TO LARGER
QUARTERS**

by Sept. 1, 1979. Brokerage continued on all sizes and types of sails both new and used. Specify sail sizes wanted for listings. Visit or ship to Bacon & Associates, Inc., 112 West St., Annapolis, Md. 21401. Or write as before to Bacon & Associates, Inc., P.O. Box 3150-S, Annapolis, Md 21403. Same phone: (301) 263-4880.

*Support Your
SNIPE CLASS!*

BOAT LUMBER

For Fine Boat Building and Repairs

SITKA SPRUCE MAST & SPAR GRADE

PHILIPPINE MANOGAMY

HONDURAS MANOGAMY

WESTERN RED CEDAR

WHITE CEDAR

OAK - TEAK - CYPRESS

LONG LEAF YELLOW

PINE - ETC.

Fir and Mahogany Plywood for marine use: lengths up to 16 feet. Bruynzeel Marine Plywood, solid Regina Mahogany throughout. Quality unsurpassed. Most sizes in stock.

Ripping and planing to order.

We are specialists in all types and sizes of imported and domestic boat lumbars. We ship anywhere - at surprisingly low prices. Send 10¢ today for valuable manual "How to Select the Right Boat Lumber" plus complete lumber and price list.

M. L. CONDON CO.
BOAT LUMBER SPECIALISTS SINCE 1912
236 Ferris Ave., White Plains, N.Y. 10603
(914) 946-4111



**NORTH SAILS are
CONSISTENTLY
the FASTEST!**



**FIRST (Gold Medal)
1979 PAN AMERICAN GAMES**

European Championship – 1
Spanish Championship – 1, 2, 3
Mid-Winter Championship – 1, 4
U.S. Championship – 2
World Championship – 2, 4, 6
Don Q, Miami – 1, 4
Bacardi Cup, Nassau – 1, 4
Dudley Gamblin, Nassau – 1, 3
North American Championship – 2, 5

Every year more and more skippers choose North Sails to improve their racing performance in fleet, state, and national competition.

NAME _____ TELEPHONE _____

ADDRESS _____
Street City, State, Zip

SHIPPING INSTRUCTIONS _____
Address

Parcel Post _____ Air Freight _____ United Parcel _____ Pick Up _____

Sail Number _____ Red _____ Blue _____ Black _____ Green _____

Main – Light (0-12 mph) 4.2 oz. \$244.00 _____
Medium (0-20 mph) 4.2 oz. _____ *Best All Purpose Sail

Heavy (18-up mph) 4.2 oz. _____
Jib – Lt/Med. (0-20 mph) 3.3 oz. \$156.00 _____ *Best All Purpose Sail

Heavy (12-30 mph) 3.8 oz. _____

Jib Adj. Tack _____ Fixed Tack _____

Mast Type _____ Boom Type _____

Price Includes Numbers, Insignia, Battens, Bag & Jib Window. On orders going to Europe, prices are approximately 10% higher.

CALL COLLECT OR WRITE

1111 Anchorage Lane
San Diego, CA 92106
(714) 224-2424 (USA)

Mercury Yacht Harbour
Hamble
Southampton SO35HR, Hants.
Hamble (042122) 3855
(England)

12-9, Nagai
Yokosuka, Kanagawa-Ken
0468-87-1262 (Japan)

We make more sails that win more races than any other sailmaker in the world.