

Editor—Wm. F. CROSBY • Published monthly by KELLY-READ & Co. INC. Rochester, N.Y. • Chet Miller ASSOCIATE EDITOR

VARALYAY'S "LOOIE POST" AN AID TO SAILORS

By Louis Varalyay

For want of a better name I call it the "Looie Post". There are several variations of it, but the one shown is the most efficient. It is simple to use and is simply a sort of elongated jam cleat. The harder the main sheet pulls, the tighter it jams. When going windward, the post is pulled over to the side to be right under the skipper's hand. When not in use it can be laid flush out of the way. It should be long enough to stick up 1 to 2 inches above the deck but short enough to pass under the deck partners when laid down. We keep it set up fairly tight as it comes in handy to grab in case of a knock down or to brace one's self. In trimming the main sheet, merely pull in as much as needed and jam the sheet into the slot from the back side. In paying out, the process is reversed. The best feature of the gadget is that in a sudden knock down a quick jerk on the main sheet and it will run free to save capsizing. I recommend it

highly to anyone because it is the only main sheet device that works efficiently and allows the main sheet to be secured but freed in an instant, something that can't be done with a cleat which can cause a capsize before you get the line free.

The Looie Post consists of a forked stick that pivots between two pieces of eight-inch angle brass. The post should be about 7/8 inch thick of ash or oak. It is held in place with a 5/16 inch brass bolt soldered to one of the angles to keep it from turning. A wing nut on the other end will adjust the tension. A swivel block is placed about 4 inches forward of the base on the floor boards. This leads the main sheet down from the boom. It should come down nearly vertical for best results and prevent interference with the post. The pictures and drawing give the general idea.

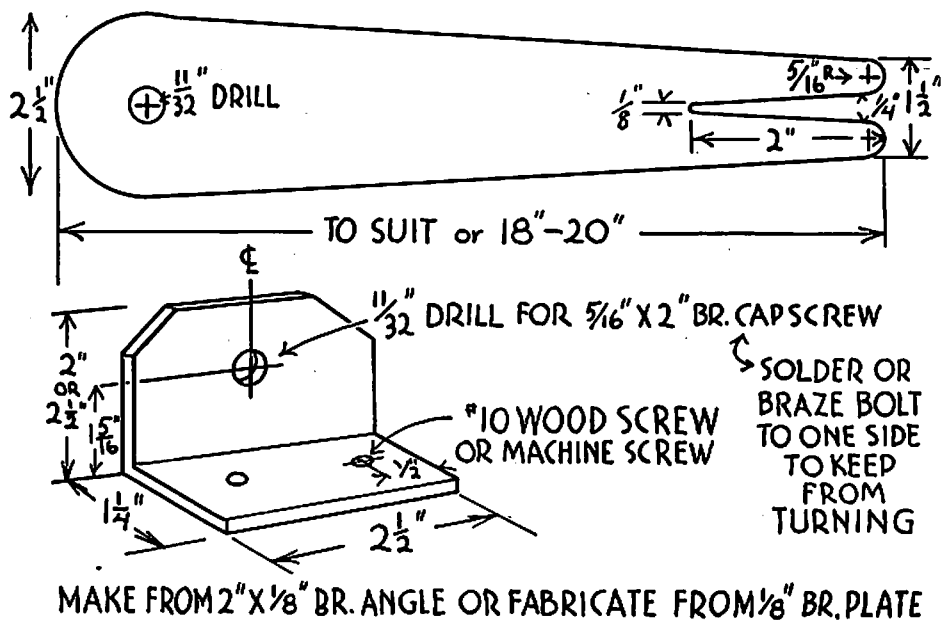
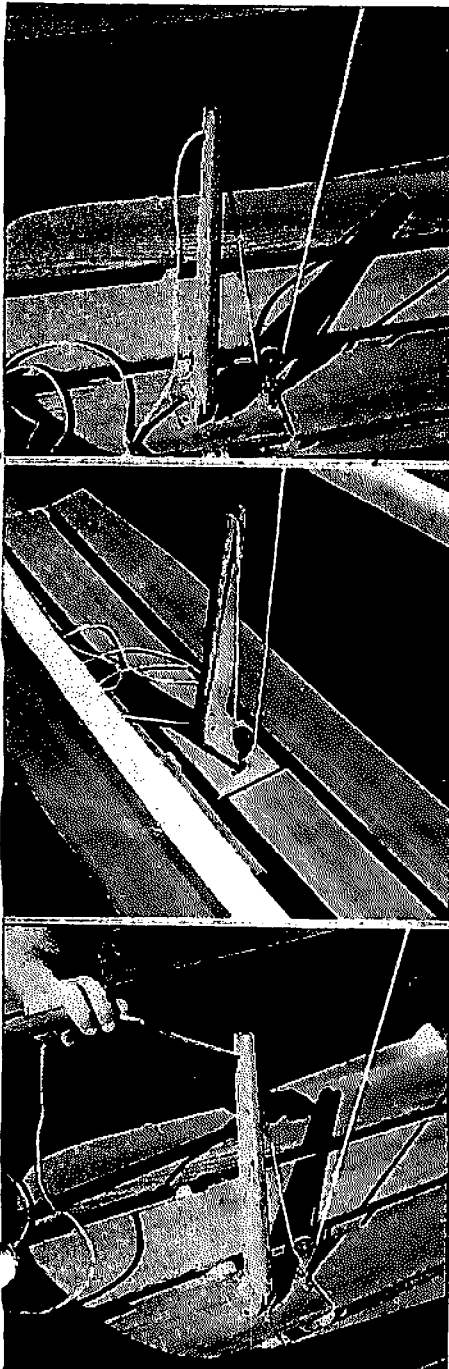

SHORT NEWS ITEMS OF SNIPE FLEETS

All Correspondence, Fleet Reports, Snipe Dues Payments, Etc., Should be Addressed to: William F. Crosby, 522 Stollar Ave., Pelham 65, N. Y.

Newest Snipe fleet to be formed is known as the Lake Parsippany Yacht Club located on the lake of the same name. The charter is number 272. Frank Apgar, RFD, 1, Morris Plains, N. J., is fleet captain. A second new fleet for New Jersey is also being formed at Lake Musconetcong, near Stanhope, N. J. This fleet will comprise five boats to start off with and, probably before this gets in type, the new fleet will be fully formed. Irving Nacht, R. R. 1, Box 35, Stanhope, N. J., is doing the organizing work.

* * * *

Melges Boat Works of Zenra, Wisconsin, near Lake Geneva, has purchased all forms, patterns, etc., from Dunphy Boat Corp., of Oshkosh for Snipes and will proceed with the construction of these boats. Some improvements will be made to bring these new Snipes in line with the latest practices. This company has long been famous for the construction of top-notch inland racing scows and will undoubtedly turn out a top rating Snipe.

* * * *

Howard Elwell, who will be well remembered by skippers who took part in several of the pre-war Snipe regattas, is now located in Minnesota and is probably the only Snipe owner in the state who is a member of the Association. Any other Snipe skippers in the vicinity are requested to contact Howard with the idea of forming a fleet. His address is 102 Clark St., Mankato, Minn.

* * * *

Walter J. Krause of the Sue Island Fleet at Baltimore Md., states that the news may now be officially released that next year they will put up a trophy and hold a regatta to be known as the Middle Atlantic States Championship. Their regatta for this year was held July 3-4 but no results have yet come in.

* * * *

Arch Higman of California brings up a point about measurement. This has come up several times before and should be straightened out here and now. He suggests that where a measurer finds a boat off several points, that the Executive Secretary be sent the data for final approval or disapproval. The rules Committee could then pass on the eligibility of the boat. Actually, it is up to the measurer to approve or disapprove a boat and if he disapproved, the owner may always take it up with the Rules Committee. Trouble is that a lot of measurers do not like to disapprove a boat and in some fleets their

work has been found to be rather careless with the result that things get by that should not. The measurer is the man who examines and measures the boat and he is familiar with what its all about. It is really up to him and if he finds things that cannot pass, he should notify an owner at once so that corrections may be made. The measurer has the final say in the matter as it is his job, the Rules Committee only acting to interpret the restrictions.

* * * *

A non-chartered Snipe fleet is known as the Pasadena Sailing Association (near Baltimore and not in California) with more than enough Snipes to form a regular fleet. Some of the members of the Sue Island Fleet are working on them to get them into active participation.

* * * *

Dick Shearman of the Lake Chautauqua fleet is also a member of the Winter Sports Committee for the Olympics and he has been quietly digging away at the possibility of having Snipes recognized for the next Olympic games. His efforts will probably bear fruit as he reports that he has had quite a few nice letters from various parts of the world and he has at least succeeded in getting the attention of the Olympic Games Committee in the matter of Snipes. With the active backing of the South Americans, Spaniards and other nations, it is almost certain that Snipe will be one of the contestants in the 1952 Olympics.

* * * *

The International Rules Committee, headed by John T. Hayward, is functioning continuously to straighten out matters of measurement and giving decisions on changes that some owners have gone ahead and made without consulting anyone. Bill Craig of the Lake Merritt (Cal.) fleet brought up the question of owners cutting away the after end of centerboard wells so that dagger boards may be tipped forward. Mr. Hayward and his committee ruled that this was not legal. Part of the ruling is as follows; "It may be that the boats you mention have had the trunk cut out merely for the sake of lightness and without any intent or possibility of misplacing the board. Cutting out, even for this purpose, is obviously against the rules and we would suggest that you read Pars. 8, 9, 23 (particularly the last two lines) and Par. 28. The measurer should, of course, compel the owners to fill in these cutouts, but should they, the owners,

wish to contest the measurer's decision, they can resort to the procedure outlined in Par. 24 and appeal to the Rules Committee where a final interpretation will be given. Of course, while the decision is pending, the boats cannot participate in sanctioned regattas and any accrued points would be provisional. It might be several months before such a decision could be completed."

The interesting part of this is that the California boats indicated in the sketch in Bill Craig's letter had the boards tiled so that the bottom was forward. A number of Snipes in the eastern part of the country, had the trunk arranged so that the board tilted in exactly the opposite direction. It is quite evident that somebody is entirely wrong. Actually, either system has been ruled out and trunks must be put in Snipes like the plans call for, so that the board will normally hang vertically.

* * * *

Oak Orchard Yacht Club at Albion, N. Y., has been reorganized and is now back in the active fold once more. The Fleet Captain is A. R. Hoot, R.F.D., Kent, N. Y.

* * * *

Correct your 1948 rule book. Fleet No. 11, the perennial Fleet Captain of the Oshkosh fleet, Harry Lund, has retired and the new Fleet Captain is Roy Biebel, 383 Monroe Ave., Oshkosh, Wis. Harry, past Commodore of SCIRA and long active in Association matters, has decided to become an author in his "old age" and is writing a bang up book on tuning up, fitting out and racing small boats, with particular stress on Snipes, of course. The book will be published in the fall. Roy Biebel, new Fleet Captain, reports ten active boats at the start of the season and more to come. We have a sneaking idea that Harry will be hanging around on race days and will give Roy a helping hand when its needed. Harry is that kind of a guy.

* * * *

Lake Mohawk Fleet is having a terrible time trying to dope out just when it can hold the North Atlantic Coast Championships and no definite dates have as yet been set. Only available date, according to Bob Edmunds, Fleet Captain, will conflict with the Harrison Trophy race late in August. We hope to be able to announce a final decision in the next issue. This trophy, by the way, is one of the oldest in the history of the class and dates back to 1933. It was originally

given by the Arthur D. Crane Co., developers of the beautiful Lake Mohawk area, and has been raced for every year since. (See page 60, 1948 rule book). It is open to one entry from every active fleet located in the waters of Maryland, Delaware, Pennsylvania, New Jersey, New York and the New England States. It has travelled around quite a little but was brought back to its original place of competition last year by Eric Hauschild who went upstate in New York and won it. If your fleet is located within the states mentioned, you should see to it that an entry is made for 1948.

* * * *

In case you didn't know, the cover of the 1948 rule book was designed by Bud Stillmun of the Money Island Fleet. Bud is a commercial artist and did a swell job on the cover.

* * * *

Entry blanks will shortly be sent to all Fleet Captains of U. S. active Snipe fleets for the U. S. National Championships at Corpus Christi, Texas, August 4-8. Requirements are that entries must be members in good standing of SCIRA and their fleet and must have taken part in at least 5 point score races this year in which

at least 5 other Snipes took part. One entry may be sent for each five active boats in a fleet. Entries must be vouched for by the fleet captain and must be sent in duplicate to the sponsoring club, Southwestern Yacht Club, Corpus Christi, Texas, and to the Executive Secretary. Each entry must be accompanied by a \$25.00 entry fee and the total sum so collected will go to the winner to pay his expenses to Spain for the World's Championship. The Texas regatta will be sailed under the 1948 rules of the North American Yacht Racing Union, while the Spanish regatta will be sailed under the rules of the International Yacht Racing Union which are the same as the old NAYRU rules in use last year. Each boat at the Texas regatta will be measured and weighed, sails will also be measured and boats or sails that do not meet class requirements will not be used. The same skipper must sail in all races but crews may be changed. The winning skipper will win the Commodore Heinzlerling National Championship Trophy and the crew of the winning boat will win the Portage Lakes Yacht Club Crew Championship Trophy. In addition, many other prizes will be given by the sponsoring club.

Important Snipe Racing Dates for 1948

The following are some of the important Snipe racing dates for this summer. Not all dates have yet been set but these are the ones that have come in so far;

July 17-18, Lake Wawasee, Indiana.

July 19-20, Canadian National Championships, Armdale Yacht Club, Halifax, Nova Scotia.

July 22-24, Southeastern Championships, Charleston, S. C.

July 21-Aug. 1, Eagle Lake, Mich.

Aug. 4-8, National Championships, Corpus Christi, Texas.

Aug. 7-8, Upper Great Lakes Championship, Gull Lake, Mich.

Aug. 14-15, Long Island Sound Individual Championship, Cedar Point Yacht Club, Westport, Conn.

Aug. 14-15, Lake Lotawana Invitational Championship, Lee's Summit, Missouri.

Aug. 14-15, Diamond Lake, Michigan.

Aug. 21-22, New Jersey State Championships, Beachwood, N. J.

Aug. 29, Harrison Trophy Race, (18 miles) Milford Y. C., Milford, Conn.

Aug. 30, Sept. 7, World's Championship, Palma, Balleric Islands, Spain.

Norge
SAILMAKERS CORP.
Yacht Sails
HAZARD KORÖDLESS YACHT ROPES AND FITTINGS
170 SECOND AVENUE
BROOKLYN 15, NEW YORK, N.Y.
Cable Address: Norgeosol



Soft, water resistant elk leather, hand-sewn—"old shoe" comfort on ship or shore. Patented Top-Sider sole with the squeegee alits, wipes each footstep dry on slippery decks.

Anti-Slip

Soles!



TOP-SIDER MOCCASINS

Men's sizes and half sizes 6 to 12. Women's sizes and half sizes 4 to 9. Brown. Ask to see the label on genuine Top-Siders.

15.75



Designed by a Yachtsman for Yachtsmen

At your dealer or direct
SPERRY TOP-SIDER
14 Main St.
Beacon Falls Conn.

New Small Boat Racing Association formed on Long Island Sound

Having been dissatisfied for some time past with the set up of the regular week end races held on Long Island Sound in the vicinity of Larchmont, members of several of the small boat classes recently formed the Small Boat Racing Association of Long Island Sound. At the initial meeting there were representatives of the Penguin Class, Wood-pussies, Comets, Snipes, and Ghost Classes. Rhodes Bantams are expected to join in and there will also probably be another class for small unclassified boats to race on a handicap basis. One of the chief gripes against the existing system was that the smaller classes didn't cross the starting lines until well after three o'clock in the afternoon with the result that they frequently didn't get back to home mooring until nearly dark. Under the new Association, it is planned to start the first class at one p.m., each race, and have the other classes follow at five minute intervals. If there is sufficient breeze and the weather is good, a second race could be held each day and permit the boats to get home long before the usual time. The Association set up calls for two delegates and an alternate from each class of boats to form the main body of the Association. From these delegates the officers would be elected. There would also be a protest committee comprising one man from each class. Arrangements for a committee and committee boat would be taken up in turn by the various classes racing so that actually no one class would have to do this chore more than two or three times during a season. The Association, at the start will represent about 75 to 100 small boats and it is expected that many more will come in as soon as the news gets around. Races will be held every Saturday, Sunday and holiday with the starting line somewhere in the vicinity of Larchmont-New Rochelle.

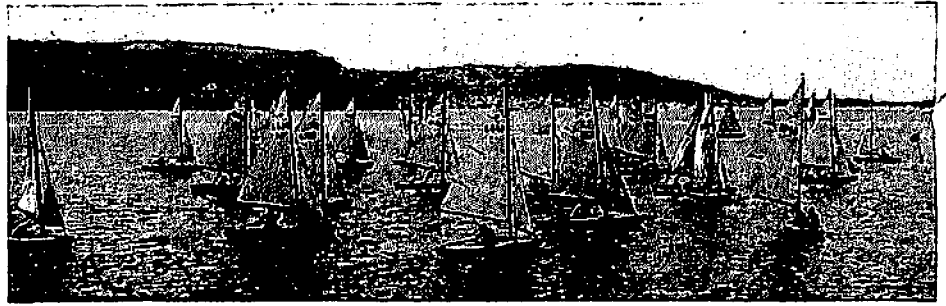

NEWS OF OVERSEAS FLEETS

Newest fleet to be chartered (No. 273) is the Yacht Club Paysandu located in Uruaguay, South America. Five boats make up the original fleet and they plan definitely on sending a boat to the World's Championships in Spain.

* * * *

A resume of the French fleets was recently sent in and we find the following fleets and the number of Snipes in each; St. Nazaire, 27 boats; Benodet, 17 Snipes; Loctudy, 32 Snipes; Paris, 13 Snipes; Rennes, 14 boats; Annecy, 7 Snipes; Leman, 5 Snipes and St. Cast, 6 Snipes. That gives a total of 121 Snipes actively racing in France. Additional fleets are forming in Concarneau, Havre and Arachon.

* * * *

From National Secretary Lasaoa-Dilla of Spain, the following has arrived; "Independently of the Commodore Hub E. Isaacks Trophy, which will be handed over to the winner of the World's Championship," we have as a first prize also a silver plate from His Excellency Generalissimo Franco. Moreover, the various Ministers of State are also sending us plates for the races. We calculate that each person who takes part, will be able to take at least one prize home as a souvenir of the championship. Just previous to the Championship we will hold the Spanish National Championship also on the Bay of Palma".

Snipes starting in Lisbon (Portugal) Sailing Week, 1947. This gives idea of the popularity of these boats in Portugal and through the National Secretary for Portugal another new fleet has just been organized in Portuguese East Africa.

RACING SNIPEs

by
"EMMONS"
with Larsen Egyptian Sails

\$500

EMMONS BREWERTON, N. Y.

NYLON ROPE

New Surplus

Per foot:
5/32" 1 1/2c; 7/32" 3 1/2c;
1/4" 5 1/2c; 11/16" 25c;
15/16" .50

Postpaid U. S.

Per coil:
1/4" \$15 for 360'
5/32" \$8 for 705'
7/32" \$40 for 1500'
15/16" \$113 for 350'
Special*
11/16" \$46 for 325'

FOB Orangeburg, N. Y.

Also: Danforth Anchors, Clocks, Barometers, etc. All surplus, new.

Write:

MAUS DARLING
SAILORS' SURPLUS
Orangeburg, N. Y.

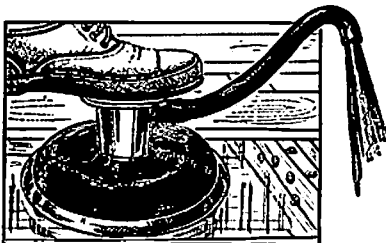

U. S. PAT. NO. 2,368,091

THE AMAZING
STEP-ON-IT
TRADE MARK REG. U. S. PAT. OFF.

BILGE
PUMP

PAT.
PEND.

— PUMPS WITH FOOT — LEAVES HANDS FREE —
PUMPS WITHOUT EFFORT. 3 1/2 GALLONS PER MINUTE.
BRONZE CASTINGS, 5' HOSE. WEIGHT 3 LBS. . \$8.75.
SIMPLE — RUGGED — COMPACT — DURABLE

Aluminum Castings, fresh water use only, weight 2 lbs. \$8.50

SEE YOUR DEALER OR WRITE

HUNT-MILLER CO. 508 ST. PAUL STREET
ROCHESTER 5, N. Y.

Custom Built

DeLuxe Racing Snipes

Nothing Finer Available

GERBER'S BOAT WORKS

689 Minneford Avenue

CITY ISLAND, 64, N. Y., NEW YORK

NATIONAL ONE-DESIGN RACING ASSOCIATION

National Notes New Officers

The Officers for the National One-Design Racing Association for 1948 are:
Commodore: R. D. Rumsey, Fleet 2, Oklahoma City, Oklahoma
Vice-Commodore: Sid Exley, Fleet 21, Long Beach, California
Rear-Commodore: Jorn Christianson, Fleet 10, Milwaukee, Wisconsin
Secretary-Treasurer: E. H. Merrill, Fleet 27, 1232 East Bartlett Street, South Bend, Indiana

All communications regarding official matters should be forwarded to Ed Merrill.

Western Championships

The activities of the Alamitos Beach Fleet 21 were initiated by a five-race Memorial Day series. Glen Walton in "Prowess," No. 476, came out on top of the eighteen starters with Sid Exley's "Glamour Girl," No. 272, second.

On June 19 and 20 Fleet 21 journeyed to meet the Palo Alto Fleet 29 for the Western Championships. "Rhapsody,"

No. 181, took first place for the home fleet by scoring 4289 points. The visitors staged a close race for second, Richard Russell in "Williwae," No. 502, with 3926 points beat out Sid Exley in "Glamour Girl" by the narrow margin of six points. The series was featured by heavy winds and heavy seas which eliminated all but five of fourteen starters in the last race.

Berquist Series

On June 19 and 20, the Eagle Lake Fleet 27 sent four boats to Wolf Lake to meet the Illiana Yacht Club Fleet 8 in the first three races of a new interclub series for a beautiful trophy donated by E. J. and Ed. Berquist. Joe Gornick, in Coamer II, No. 295, gave the Eagle Lake boys quite a lesson by neatly winning all three races. John Makielski, in his new "Sheba," No. 147, lead the Eagle Lake fleet by taking fourth place in the standings. The Illiana fleet hopes to send at least eight boats to Eagle Lake July 31 and August 1 for the second half of the series.

World Championships

The big days for the Nationals this year come July 30 and 31 and August 1, when the Alamitos Bay Fleet 21 plays

hosts to the association. It should be a wonderful series and every fleet should be represented! Send in entries to Fleet Captain John Munholland, 1st National Bank Building, Long Beach, Calif.

Southeastern Championships are scheduled for August 6, 7 and 8 under the auspices of Fleet 3 at Charleston, South Carolina. Entries should be forwarded to Fleet Captain Tom Bennett, 26 Meeting Street, Charleston, S. C.

Michiana Championships are scheduled for the same weekend, August 7 and 8, at Eagle Lake Yacht Club (Fleet 27). For further information, address Fleet Captain John Makielski, Eagle Lake, Edwardsburg, Michigan.

Great Lakes Championships will be held August 14 and 15 at the Leland Yacht Club (Fleet 26), Lake Leelenau, Leland, Michigan. It is a beautiful lake and the plans for the regatta assure a swell time for all. Address request for information and registration to Dr. Richard Waite, 3820 Lawrence Street, Detroit, Michigan.

Malcolm England and Clarence and Fred Downing of the Alamitos Bay fleet have registered boats No. 525 and 526 and Clifford Madson of Illiana Yacht Club, boat No. 527,

William H. Griffin

Yacht Sailmakers

Established 1863

Tel. ESplanade 2-7392



Marine Basin

Foot 26th Avenue

Brooklyn 14, New York

Varalyay

BUILT SNIPE

are the
Boats
to watch
at the
Nationals

Gardena

Calif.

Eddie Williams of Kansas City Wins International Point Championship

SNIPER POINT SCORES FOR SEASON ENDING MARCH 31st, 1948

Score	Boat, Owner, Fleet	Races
1750	No. 5933, E. W. Williams, Missouri Y. C.	15
1745	Rub-a-Dub, J. Stillman, Jr., Money Island Y. C.	17
1735	Up-n-Atom, C. D. Zimmerman, Portage Lakes Y. C.	16
1731	Sinbad, D. R. Simonds, Jr., Winchester B. C.	17
1717	Bozo, Sid Forsay, Northern Y. C., (Nova Scotia)	14
1715	No. 4582, A. A. Wild, Dallas Snipe Fleet	16
1706	Dodger II, E. J. Hauschild, Lake Mohawk Y. C.	18
1705	No. 3752, L. Vanderveide, Green Lake Y. C.	15
1700	Femor 2, F. Rozniacki, Oslo, Norway	10
1695.9	Tiger, Jack Wirt, Miami Y. C.	18
1695.3	No. 4144, Charles Lillin, Sea Cliff Y. C.	13
1687	Wildhoney, Roy Biebel, Jr., Oshkosh Y. C.	12
1684	Ze Carioca, R. Soares de Oliveira, Lisbon N. C.	10
1681	Ducky, Billy Wicker, Southwestern Y. C.	11
1676	6 C's, R. T. Cass, Mile High Boat Ass'n	16
1675	Jinx, Ray Kau'nan, City Island Snipe Fleet	13
1673	Pipoca, Jean R. Maligo, Rio de Janeiro	4
1670	Sad Sac, Elaine Kirschman, Corinthian, San Francisco	7
1663	Kiwi, A. C. Jephson, Southwestern Y. C.	13
1661	Cythere, Albert Steiner, Geneva, Switz.	12
1660.8	Wee Willie, Donald Munson, Jr., Privateer Y. C.	11
1660	Tart, J. T. Hayward, Sequoyah Y. C.	11
1654.3	Chasme II, Chas. Gabor, Lake Mohawk Y. C.	13
1654	Princess, J. and C. Nicholson, City Island	18
1653	Stinger, Johnsen-Billburg, Chicago Corinthian	16
1652	Argyle, Donald MacIvor, unidentified fleet	18
1650	Fancy Nancy, Hjalmar Amundsen, City Island	5
1650	Dipper III, P. H. Greene, Balboa, Cal.	5
1647.9	Rebel, John Montanari, Miami Y. C.	7
1647	Eleanor, W. W. Valentine, Potomac River Fleet	16
1646	Blue Nose II, Don Cochran, Clearwater Y. C.	6
1646	Rogue, Pierre Havre, Lake Merritt, Cal.	9
1637	No. 4193, Dick Carpenter, Sequoyah Y. C., (Okla.)	13
1636	Marilita, Dr. Antonio Santos e Silva, Portugal	10
1635.9	Lady Sandra, Ken Schmid, Chicago Corinthian	18
1635.1	Blue Jay, D. C. Laurer, Sodus Bay	12
1635	Sherry, B. E. Simpkins, Missouri Y. C.	15
1634.5	Gaybu, Ademar Bezerra de Melo, Pernambuco	13
1634.2	Rascal, J. Mc. Hardin, Shelbourne, N. S.	5
1634	Ripple, T. & L. Murphy, Armdale, Nova Scotia	6
1632	No. 3494, George Michel, Jr., Lake Mohawk	17
1632	Shady Too, Garfield-Lundquist, Chataouan Lake	11
1630	Wild Hard, Jack Streeton, Winchester, Mass.	12
1629.8	Thrid, Brooks Applegate, Portage Lakes	14
1629.5	Allegra, Bob Cousar, Privateer Y. C. (Tenn.)	10
1629	Nina, J. Munoz Bustamante, Havana, Cuba	9
1628	Protest II, Lee Short, Sodus Bay, N. Y.	10
1627	Suzabelle, J. Montague, Money Island, N. J.	22
1624	Romar, G. C. Glannou, Topsail Ass'n, Newfoundland	8
1623.3	Little Chic, K. Nicholson, Jr., Money Island	24
1623.3	Hotte Rodde, John Hannafourde, Miami Y. C.	16
1622.2	Elisabeth, Pribeus-Rodrigues, Portugal	10
1622	No. 6607, Oelvro de Sousa-Timos, Portugal	12
1620.8	4 Aces, George Glenn, Nine Mile Pt., N. Y.	20
1620.1	Tommy Jay, T. J. Carroll, Gull Lake	5
1618.5	8-Ball, Ben Moore, Dallas, Texas	14
1618	Spirte, J. M. Raphael, Mile High Boat Ass'n	15
1610	Ewa 2, Conral Lambert, Sequoyah	12
1607	Rocket, Tom Chapman, Beachwood, N. J.	6
1606	Cavort, George Sawyer, Milford, Conn.	12
1602.7	Siri, H. W. Orr, Pernambuco	8
1602	Mazella, R. C. Mewa, Topsail Ass'n, Newfoundland	8
1601	Jane L. III, C. R. Miller, Nine Mile Point	15
1598.5	Mischief, Linda Morse, Green Lake, Wis.	15
1598.4	FBI, Joe Remlin, Cedar Point, Conn.	14
1597	Gremlin II, Don Gray, Jr., Cedar Point	15
1595	Ola, I. Y. Halsey, Three MI Harbor, N. Y.	6
1594	Salpico, Fernando Dentinho, Portugal	8
1593	Storm Along, Raymond Mills, Lake Quassapaug, Conn.	6
1592	Abbu, R. Tomlinson, Portage Lakes	13
1591.1	Maria Luisa, Club Naval de Lisbon, Portugal	10
1591	Sellback, Edward Trunk, Sea Cliff, N. Y.	10
1591	Ruth II, W. E. Holmes, Sodus Bay, N. Y.	10
1590	Sans Souci, van Eykens, Rio de Janeiro	15
1587	No. 5956, Hurh Jamieson, Dallas, Texas	9
1587	Pepper Ann, Dave Walbridge, Gull Lake	5
1582	Santu, J. M. Henry, Sequoyah Y. C.	6
1580	Heathen II, Frank R. Rogan, Wichita, Kansas	14
1578.8	No. 6608, Brites-Dalhado, Portugal	15
1578.1	Xareu, J. Pinho Filho, Rio de Janeiro	16
1575	O-G, Tom Hann, Nine Mile Point	18
1574	Seaweed, Elinor Bergstrom, Sea Cliff	14
1573.4	Dixie Flyer, Dixie Roberts, Privateer Y. C.	15
1573	Voyager, Joe Kates, Havana, Cuba	8
1571	Tally Ho, Emil Sodke, Charleston Y. C.	5
1567	Ann Lee III, Clarence Watson, Wichita, Kans.	15
1564	Cisco, E. de Paiva Samico, Pernambuco	13
1564	Mishap, Robert S. Allen, Potomac River	7
1557.9	No. 4381, John Heskitt, Portage Lakes	15
1557	Sauste, Jose Ponce Pires, Portugal	6
1555.4	Hi 30, W. M. Hannay, Missouri Y. C.	11
1555.1	Dongo II, Gary Hoyt, Beachwood, N. J.	8
1554	Crisplan, John W. Rix, Wichita, Kansas	15
1553.7	No. 6106, Bruce Huston, Sodus Bay	8
1553.5	Mafa, A. Astephen, Northern Y. C. (Nova Scotia)	13
1552	Marinam J. O. Bryden, Northern Y. C.	9
1548	Sea Duce, Robert Cohen, City Island, N. Y.	13
1547	Disord, Jim Kretchner, San Francisco Corinthian	7

"For Those Who Care"

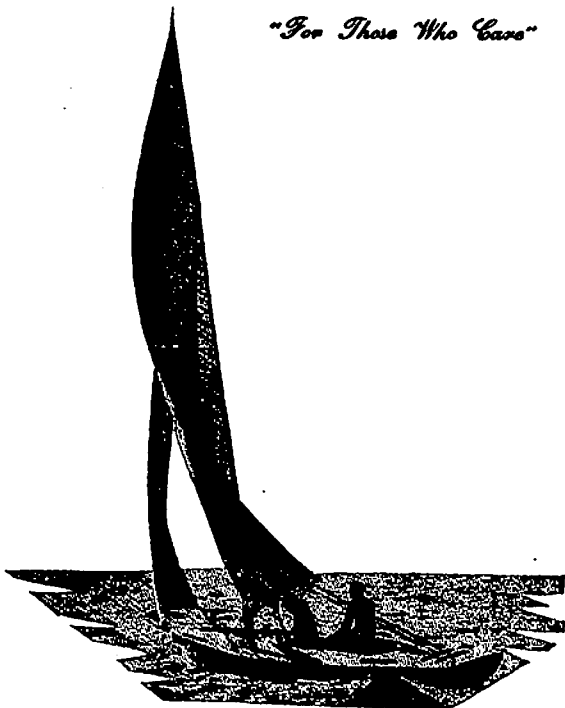

Ira S. Caldwell & Co., Inc.
Yacht Sailmakers
BEAUFORT, S.C.

Snipe Frame Kits

Only \$75.00

Tell Your Friends

Herbert F. Guenin and Associates

Noraton Heights

Connecticut

Custom Built Racing Sails



of the finest imported
Egyptian cotton and Wamsutta

LINCOLN H. FOSTER

181 Main Street

Oshkosh, Wisconsin

1545.4	Dipsy Doodle, John Pyatt, L. Quassapaug, Conn.	16	1431	Hot Rock, Wm. Lundgren, Chicago Corinthian	16
1545	Rafaela, Club Naval de Lisbon, Portugal	10	1430.1	Folache, Vetter, Geneva, Switzerland	12
1544.6	Ninan, N. A. Jacques de Silva, Portugal	10	1430	Spray, T. Giannou, Topsail, Newfoundland	6
1544.5	Foray, J. A. Newman, Winchester, Mass.	6	1426	Marum, Club Nautico Mare Nostrom, Portugal	9
1543.5	Hussy, Jerry Chambers, Chicago Corinthian	16	1425.4	Hardtack, John Liddell, Lake Merritt, Cal.	6
1543	Okay III, John Snow, Armadale, Nova Scotia	6	1425	N Run, Elizabeth Hedburg, Beachwood, N. J.	8
1542.7	No. 4300, J. W. Davis, Dallas, Texas	14	1424	No. 3456, Max King, Balboa, Cal.	5
1542.4	Pipe Dream, Charles Frost, Sea Cliff, N. Y.	14	1423	Suzana, Justan Goncalves, Pernambuco	8
1542.3	Dot, Vincent Logan, Nine Mi. Point, N. Y.	19	1422	Yearling, Gill Zeartsky, Green Lake, Wis.	15
1541	Silk Chik, Mike Anderson, Oshkosh, Wis.	12	1421.6	No. 1009, J. Musselman, Money Island, N. J.	16
1540	No. 4213, Dick Deaver, Balboa, Cal.	5	1421.6	No. 6959, Hiram Upson, Lake Quassapaug, Conn.	9
4225	Good News II, T. A. Wells-Art Lippitt, Wichita	12	1420.2	Noelle, Cann & Gallop, Northern Y. C.	9
1539.8	No Name II, Jack J. Lesemann, Charleston	7	1420	No. 4188, Frank Nelson, Sequoyah	5
1539	No. 4752, Marcia Fite, Sequoyah Y. C. (Okla.)	16	1419	Hiho, Ferris Halsey, Three Mi. Harbor	5
1536	No. 202, George Schwenk, L. Quassapaug, Conn.	16	1418.1	Zephyr, Chas. S. Bills, Potomac River	7
1535	Sandra, W. F. Piper, Missouri Y. C.	15	1418	Sarda, Bernardo Arnoso, Portugal	6
1533	Alibi, Patricia Hurley, Cedar Point, Conn.	16	1415	Comet, Reg. and E. H. Press, Topsail	8
1531.6	No. 5548, Geo. T. Jones, Winchester, Mass.	26	1414.2	Challenge, Jean Blanchard, West. L. I. Sound	6
1531	Sybil-Ann, J. T. Seldorff, Western L. I. Sound	5	1414.1	Jiffy II, Dr. E. F. Moores, Avalon, Newfoundland	9
1530.4	Iluc Norse, Fred Deere, Dallas, Texas	10	1413	Green Hornet, Fred L. Blair, Avalon, Newfoundland	7
1530.38	Shirley Jean, Sid Buka, Mile High Boat Assn	16	1411	Melody, Bob Merwin, Milford, Conn.	12
1530.33	Suao, J. Castel-Branco, Portugal	6	1407.2	Sea Wolf, Ruth Graim, Green Lake, Wis.	15
1528	Rum Lum, Eugene Roberts, Charleston	5	1407	No. 6483, Robert Morris, Winchester, Mass.	6
1527	Escunio, Isaias Quintana, Havana, Cuba	9	1404.4	Thumper, Patsy Leach, Oshkosh, Wis.	9
1525	Shady Lady, Norman Bell, Lake Merritt, Cal.	14	1404.3	Melody Lee, Kel Ehrman, Gull Lake, Mich.	5
1524.8	Phantom, Elton Edoy, Lake Merritt, Cal.	5	1401	Sprite, Arthur Johnson, Avalon, Newfoundland	7
1524.5	Skipper, Pete Leach, Oshkosh, Wis.	8	1400	Kappa, Wm. Parenteau, Sea Cliff, N. Y.	9
1523	No. 5833, Loureico-Oliveira, Portugal	14	1399	Gaivota, A. Cordoso Moreira, Pernambuco	10
1521.5	No. 3741, R. S. Gazzaldi, Dallas, Texas	22	1398	Lucky II, Wm. Errico, City Island	10
1521.5	Fanny Dunker, M. Styversen, Milford, Conn.	11	1393	Con.usion, Calvin L. Duncan, Missouri Y. C.	5
1521	No. 1165, Chas. Rafford, Lake Quassapaug, Conn.	16	1391	No. 5440, Bello Brothers, Lisbon, Portugal	13
1520.5	Rabbitt, Pete Schoonmaker, San Francisco Corinthian	5	1390	No. 964, Harry Widmeier, Jr., Money Island, N. J.	25
1520.1	Hoodwink, B. Sawyer, Beachwood, N. J.	7	1389	Dolphin, Randolph Wilson, Privateer Y. C.	11
1518.7	Cotton, Pete Newell, Lake Merritt, Cal.	14	1383	Savel, Eurico Rosa, Portugal	6
1518	Thunderhead, Geo. Packer, Armadale, Nova Scotia	6	1382.9	Warob, Wm. R. Blakely, Wichita, Kansas	13
1516.8	Gnat, L. W. Greene, Jr., Mile High Boat Ass'n	7	1382.8	Miown Too, Robert Brown, Avalon, Newfoundland	11
1516.2	My Sin, Stanley Stone, Jr., Green Lake, Wis.	15	1382.3	Wing II, W. B. Ingwerson, Mile High Ass'n	14
1515	Blue Horse II, Bruce Jamieson, Dallas, Texas	8	1378	No. 3222, L. Blatterman, Balboa, Cal.	5
1513	No. 5832, Portugal	15	1377	No. 1872, Joe Essick, Jr., Money Island, N. J.	25
1511	Sparkle Plenty, Gerald Smith, Shelbourne, Nova Scotia	5	1377	Scrappy II, Wallace Roworth, Nine Mile Point	20
1510	Skipper, Donna Sandkam, Western L. I. Sound	5	1376.4	No. 3899, Drew Gram, Balboa, Cal.	5
1509	No. 3158, Eddy Gavney, Gull Lake, Mich.	5	1376	Annette II, Billy Doscher, Charleston, S. C.	5
1508.8	Tee Bees, T. E. Burlolizh, Jr., Winchester	24	1375	No. 4279, W. T. Rainey, Sequoyah Y. C.	5
1508.7	Spray, Al Ciecchowski, City Island, N. Y.	10	1370	Wench, David Graham, Cedar Point, Conn.	16
1508.2	Dusty Too, H. Korsnoik, Cedar Point, Conn.	15	1368.5	Eda, Jorge Basilio, Rio de Janeiro	12
1508.1	Buss Lany, Edw. Meyers, City Island	13	1368	No. 2494, Mulhall-Ramey, Sequoyah	7
1505.7	No. 5868, Raymond Bingham, Mile High Boat Ass'n	14	1366	No. 5708, Mary L. Probeck, Portage Lakes	14
1505	Skipper, W. W. Barker, Potomac River	6	1365	Edsu, Ed and Sue Tillman, West. L. I. Sound	5
1504.7	Viking, C. White, Northern Y. C.	7	1363	My Joy, Claude Huguerin, Geneva, Switzerland	12
1504.3	Albran II, Barber, Thierry, Geneva, Switzerland	9	1361.8	Honey, Wade Carruth, Southwestern Y. C.	5
1504.1	Doll, Charles Otto, Chica-o Corinthian	12	1361.6	Halloray, Harold Rensch, Chicago Corinthian	15
1501.1	Slalom V, Victor Larsin, Chautauqua Lake	12	1360.8	Buzzy, Tommy Mayfield, Southwestern Y. C.	8
1504	Draggin' Lady, Dave North, Sea Cliff	7	1360.6	No. 6447, Betty Zinn, Gull Lake	5
1503	Flaan, James Finch, Chicago Corinthian	22	1360.5	No. 3306, John Wilson, Lake Mohawk	21
1501.0	Sea Sharp, Richard Elley, Money Island, N. J.	23	1360	Oui Tu, John Pyatt, Jr., L. Quassapaug, Conn.	9
1501.6	Lady-O, Joseph Thompson, Chicago Corinthian	15	1359	Lulu, Jack McMahon, Cedar Point, Conn.	16
1500	No. 3030, Earl Fetzer, Dallas, Texas	11	1357.6	Var Drom, Hugo Velander, Chicago Corinthian	13
1496	Genie, Jim Cole, Privateer	12	1357	Echo, Arthur Johnson, Avalon, Newfoundland	9
1495.9	Annie-E IV, Belford & Russell, Chautauqua Lake	11	1357	Linda Lou, G. E. Mays, Sequoyah	7
1495	Tolinha II, J. Teixeira Leite, Pernambuco	13	1355.2	Sioux, Joe Kronzer, Jr., Oshkosh, Wis.	10
1494	Samoa, Joe Ilmberger, Chicago Corinthian	17	1355	Foray, A. G. Litchfield, Winchester	11
1492	Jerry L., II, Kaymon J. Luckett, Southwestern Y. C.	10	1345	Belpean, Belfield Carter, Privateer Y. C.	13
1491	Who Cares, Dick Roth, Miami Y. C.	16	1342.4	Rascal, W. G. Layson, Privateer Y. C.	13
1488	Rosi II, Gonzalo Diaz, Havana Cuba	8	1342.2	No. 5545, Lynn C. Dubois, Sodus Bay, N. Y.	12
1487	Jeanette, W. S. Comerford, Topsail, Nova Scotia	8	1342	Jabberwocke, Len Holskin, City Island, N. Y.	9
1483.4	Alin, Fred Rochat, Geneva, Switzerland	12	1339.8	Lucky, Wayne Elliott, Southwestern Y. C.	8
1483	Margie, Freca Herschberger, Missouri Y. C.	15	1339.4	Salome, James T. Snow, Winchester, Mass.	13
1482.6	No. 2090, Donald Bowman, Lake Quassapaug	16	1335	Owha, Jane Rey, San Francisco Corinthian	5
1482.3	No. 1346, Mat Hammond, Lake Mohawk, N. J.	19	1333	Q-T, Jack Hanna, Nine Mile Point, N. Y.	15
1482.2	Patty-Ann IV, Cliff Hine, Chautauqua Lake	11	1330	Hard Tack II, Geo. B. Field, Winchester, Mass.	23
1481.8	Olive Moore II, Lon Clouston, Avalon, Newfoundland	7	1329.7	Youani, Bart V. Sullivan, Winchester, Mass.	18
1481.7	Slopoke, Art Stock, Missouri Y. C.	14	1329.6	No. 270, Richard Torpey, Money Island, N. J.	10
1480	Tigger, J. N. Byers, Potomac River	5	1326	No. 5221, R. Montague, Money Island, N. J.	15
1579	Havoc, Dick Kitz, Oshkosh, Wis.	12	1325	Ibis, Candido B. Toledo, Havana, Cuba	8
1574	Busy Bee, Edwin Kaiser, Mile High Boat Ass'n	14	1323	Clipper, John R. Hayden, Sodus Bay, N. Y.	9
1478	Kabini, Owen Luffy, Privateer Y. C.	14	1320	Idler IX, Dick Shearman, Chautauqua Lake, N. Y.	7
1472	No. 3305, Olin Lenecke, Lake Mohawk, N. J.	18	1318	No. 2901, James Moody, Portage Lakes	8
1471.9	Julie Joan II, Geo. Cartland, Portage Lakes	13	1317.2	Candace, Kenneth Peterson, Nine Mile Point	15
1471.6	Darl, D. Fraser, Northern Y. C.	12	1317.1	Doghouse too, Walter Newcomb, Nine Mile Point	8
1469	Jet, George B. Jost, Avalon, Newfoundland	6	1317	Jay-Gee, C. E. Syderstricker, Potomac River	5
1468	Swanee, R. L. Swanson, Winchester, Mass.	22	1316	Fraidicu II, Soldat, Geneva, Switzerland	10
1467.5	Gipsy, Tony Ferri, Charleston, S. C.	6	1312	Sanzie, Frances Osborne, Privateer Y. C.	10
1467.3	Solano, Muriel Vadersen, Money Island, N. J.	14	1309	R-Go, Richard Barker, Nine Mile Point	20
1466	Whozat, Joe Schrank, Oshkosh, Wis.	12	1307	Gem, Bob Killian, Lake Merritt, Cal.	5
1465.6	Sea Bisquit, Roy Smith, Shelbourne, Nova Scotia	15	1303	Alcedo, Patricia Moore, Money Island, N. J.	20
1465	Gulvinia, Gamo-Rocha, Portugal	12	1298	No. 3707, C. R. Huston, Missouri Y. C.	8
1463	Marmouset, Pierre Jaeger, Geneva, Switz.	12	1295	No. 2618, Pat Coombs, Portage Lakes	9
1463	No. 1171, E. M. Osborne, Three Mi. Harbor	5	1290.8	Sinbad, E. J. H. Laplan, Rio de Janeiro	15
1461.7	Can-do, Harry Allen, Cedar Point, Conn.	15	1290.4	Dunning, Dr. Art Campbell, Missouri Y. C.	7
1461.1	Mackin, Wm. Mackinley, Northern Y. C.	8	1284	Moby Dick, Dwight Westholt, Missouri Y. C.	13
1461	Outlaw, Russell Rydin, Chicago Corinthian	14	1282	Gaviota, Ribero and Coutierho, Portugal	14
1460.6	Jhger, Herb Townsend, Lake Merritt, Cal.	8	1281	Teybo II, Gonzalo Melendez, Havana Cuba	5
1460.4	Albatroz, Menzes-Campanella, Portugal	15	1280.5	Trade Wind, Ed Kaufman, Lake Merritt, Cal.	10
1455	Drizlepuss, Edward Morse, City Island	6	1280.1	Sonorita, Betty Clemons, Milford, Conn.	12
1454	Emmy, Frank W. Halsey, Three Mi. Harbor, N. Y.	6	1276	Wasp, David Whitson, Beachwood, N. J.	6
1453.7	Vida Boa, F. J. Pimentel Duarte, Rio de Janeiro	16	1271	Drippin', Bert Knopf, Milford, Conn.	12
1453.1	PDQ, Jean McCormick, Cedar Point, Conn.	16	1269	No. 5521, J. M. Obert, Money Island, N. J.	16
1452.9	No. 3870, Charlie Williams, Dallas, Texas	12	1266	No. 4274, Russell Doerinker, Lake Mohawk, N. J.	16
1452	Doquinha, D. Fernandes Tinoco, Lisbon, Portugal	10	1254	Delfin, Armano Gordillo, Havana, Cuba	8
1451	Raptured Duck, H. Whittemore, III, L. Quassapaug	10	1250	Wee-One II, Gordon and Tim Kay, Chautauqua Lake	11
1450	Yahudi, Pat Hollowed, Portage Lakes	8	1247	Pinto, Shanahan-Hahr, Chautauqua Lake	12
1449	No. 538, Robert Edmonds, Lake Mohawk	20	1246	Chance, Ed. Chobot, Privateer Y. C.	8
1445	Ballyhoo, Ann Bellinger, Miami	13	1244	Pizit II, Bruce Baldwin, Chautauqua Lake	11
1443	Toy, Mota e Souza, Portugal	9	1242	Myth, Tom Oldroyd, Milford, Conn.	12
1442	Mox-Nix, Wm. M. Ames, Wichita, Kansas	11	1239.6	Ruthie, W. W. Weber, Missouri Y. C.	14
41	Taffy, Milton Taffet, City Island, N. Y.	7	1239.3	Ack-Ack, Gene Henderson, Southwestern Y. C.	6
40.4	Little Red Robert Meyer, Southwestern Y. C.	8	1237.5	Sky Lark, Douglas Campbell, Beachwood	8
1440.3	Reynard, Bruce Roth, Beachwood Y. C.	8	1237	No. 5873, Ann Burns, Sodus Bay, N. Y.	7
1439	Cotton Too, Terry Grew, San Francisco Corinthian	7	1233	Milky Way, A. & D. Kleppner, Western L. I. Sound	17
1434.4	Sunset II, S. J. Rudolph, Jr., Shelbourne, N. S.	5	1229	Jam, Melvin Moller, Winchester, Mass.	5
1434.4	Night Cap, Wm. Archibold, Shelbourne, N. S.	5	1226.6	Tell-Tale II, Griffith-Heston, Lake Chautauqua	11

1226	Almirante, Juan M. Muller, Havana, Cuba.....	9
1220.7	Jane L., Mary Jane Scriggins, Cedar Point.....	16
1220.2	Dunlin, Parker H. Blanchard, Winchester.....	5
1217	Christy, Julio Gardano, Havana, Cuba.....	7
1215	Rondic, Rodney Long, Winchester, Mass.....	19
1207	Yankee Doodle, Earl Kitts, Nine Mile Point.....	6
1201	Michou, Robert Bollon, Geneva, Switzerland.....	10
1200	Moleza, Thomaz und Freire, Rio de Janeiro.....	11
1198	Snekur, Raymond Leclere, Geneva, Switzerland.....	6
1185	Tino, Tiodoro Lopez, Lisbon, Portugal.....	10
1183	Fifinella, Joan Gray, Cedar Point, Conn.....	14
1178	The Foo, T. D. Blamire, Winchester, Mass.....	21
1177	8-Ball, Mary Hough, Chautauqua Lake.....	10
1169	No. 3304, John Steinberg, Lake Mohawk, N. J.....	6
1166	Sylvia II, Harold Radford, Chautauqua Lake.....	12
1162	Zip, Douzlas Kennedy, Chicago Corinthian.....	7
1161	Quest, Walt Kenyon, Lake Merritt, Cal.....	6
1156.8	Pixie, Margaret Hall, Lake Mohawk, N. J.....	5
1156.3	Soneca, Dale and Bastos, Rio de Janeiro.....	15
1141	Phooka, Harold Pyne, Winchester, Mass.....	18
1127	Luxury, Robert Swider, Chicago Corinthian.....	5
1108	Eap II, Les and Ed Powers, Chautauqua Lake.....	12
1107.7	No. 11, Phillip Ratchford, Lake Mohawk.....	8
1107	Dusby, Gustavo Carvalho, Rio de Janeiro.....	16
1106	Pipaqueak, Bill Boyce, Milford, Conn.....	12
1090	No. 1703, Carl Christensen, Lake Mohawk.....	10
1087	Kisco, Marc d'Espine, Geneva, Switzerland.....	6
1086	Aphrodite, C. N. Bristol, Milford, Conn.....	12
1081	Hoi-Toi, Richard Meyers, Milford, Conn.....	10
1069	No. 5854, Gust E. West, Winchester, Mass.....	6
1064	No. 117, Thomas Munro, Lake Mohawk, N. J.....	14
1062	Foot-Loose II, Harold Irwin, Jr., Chautauqua.....	10
1056	Toninha, Calo Sylla, Rio de Janeiro.....	11
1050	Ace, Joan Larson, Winchester, Mass.....	9
1048	Valory II, Stierli, Geneva, Switzerland.....	5
1046	Rainbow, Luc Thudicum, Geneva, Switzerland.....	17
1044	Batuke, Paulo Cesar de Oliveira Gomes, Rio.....	5
1034	Blich-Brak, Jean Trolllet, Geneva, Switzerland.....	7
1022	Perigo, Wm. and Armando Normann, Rio de Janeiro.....	14
1017	Gina, Ludovico & Joao Sommers, Rio de Janeiro.....	7
1011	Minuano, Pereira & Epreira de Souza, Rio.....	9
996	No. 2820, Fairchild & Stevenson, Missouri.....	5
982	No. 3302, Carl Tannert, Lake Mohawk, N. J.....	6
959	Tiririca, Marita Thire, Rio de Janeiro.....	16
957	Chippee, Earl Diener, Winchester, Mass.....	12
927	Simun, Roberto Pompeu, Rio de Janeiro.....	8
926	Corumar, Elmano Araujo, Rio de Janeiro.....	8
913	Junior ? / ? / ? Geneva, Switzerland.....	6
909	Hic-Cup, Tom Lindquist, Chautauqua Lake.....	8
887	Rainbow, Bob and Jean Kinney, Chautauqua Lake.....	7
881	Pancho, F. J. Telles Rudge, Rio de Janeiro.....	6
848	Pan, Carlos Alberto Villanova, Rio de Janeiro.....	12
778	Icautu, Ilse Holck, Rio de Janeiro.....	9
689	No. 6103, Gilberto Tinoco, Rio de Janeiro.....	8
514	Pashah, Luiz Otavio Silva, Rio de Janeiro.....	6

SMOKABILITY
TRADE MARK

30¢ **30¢**

MELLOW AS MOONLIGHT

R. R. TOBIN TOBACCO CO.
408 E. WOODBRIDGE ST., DETROIT, 26, MICHIGAN

SAMPLE ON REQUEST

FOR SALE Snipe No. 4765

Former Long Island Sound Champion Trailer and Mooring plus Joys Bros. sails. Make offer.

GEORGE HARTMANN
Valley Cottage, N. Y.

ORDER YOUR SNIPE PLANS
THROUGH JIB SHEET
\$5 00 per set

This size space
\$2.00 per issue

CHARLES ULMER, INC.

CITY ISLAND 64, N.Y.

Entire Contents Copyright, 1948—Kelly-Read & Co., Rochester 5, N. Y.

ALL SUBSCRIPTIONS TO
JIB SHEET

KELLY-READ & CO., Inc., Publishers
508 ST. PAUL ST.,
ROCHESTER 5, N. Y.

From
JIB SHEET
KELLY-READ & CO., Inc.
508 ST. PAUL ST.,
ROCHESTER 5, N. Y.

Sec. 562, P. L. & R.
U. S. POSTAGE
PAID
ROCHESTER 5, N. Y.
PERMIT No. 256

PLEASE ENTER MY SUBSCRIPTION TO " JIB SHEET " FOR

U.S.A.
1 year \$2.50
2 years 4.50

FOREIGN
1 year \$3.00
2 years 5.00

TO BEGIN WITH THIS ISSUE

NAME _____

ADDRESS _____

CITY _____ ZONE _____

STATE _____

SUPPER ADDRESS (if any) _____

CLASS _____

BOAT NUMBER _____

CLUB _____

BOAT NAME _____

If you have sold your boat, please send us the new owners name and address.

1910

1910

1910

1910

1910

1910

1910

1910

1910

1910

1910

1910

1910

1910

1910

1910

1910

1910

1910