



BULLETIN

February/March 1999



Sobstad
San Diego

2832 Canon St.
San Diego, CA
92106

Telephone
(619) 226-2422
Fax Number
(619) 226-0682

www.sobstad.com
szabo@sobstad.com

“Out of the Box” Tuning Video

Have you ever wondered if you are really setting up your boat the same way as the tuning guide suggests, or thought 'is this what they mean?' as you read the tuning guide. Would you be interested in seeing everything that George Szabo and Eric Wilcox did to get their new snipe #29672 ready for racing?

With the help of Vince Cassalaina, a thorough tuning video was produced that begins with the unwrapping of Snipe number 29672 after shipping and shows how George and Eric:

- added necessary rigging,
- rigged the pole launcher,
- straightened the mast,
- measured and tweaked their spreaders,
- tuned the mast both off and on the water,
- marked and measured the boat for easy duplication of sail settings,
- use the main controls in different wind strengths,
- move the jib lead and jib sheet with changes in the wind and waves,
- play the jib halyard off the wind, and
- roll tack and roll jibe.

Whether you are a new to Snipes or you could use a few tips to improve your racing, we are sure that you will find value in this 30 minute video. You can order your copy from Sobstad or from SCIRA for \$15 plus shipping. All proceeds go to SCIRA. Overseas video formats are also available.

1999 results: 2nd Brazilian Nationals, 1st Florida State Champs, 1st Las Vegas Regatta, 1st SCYA Midwinters



WINTER RACING CIRCUIT

& US Pan Am Trials

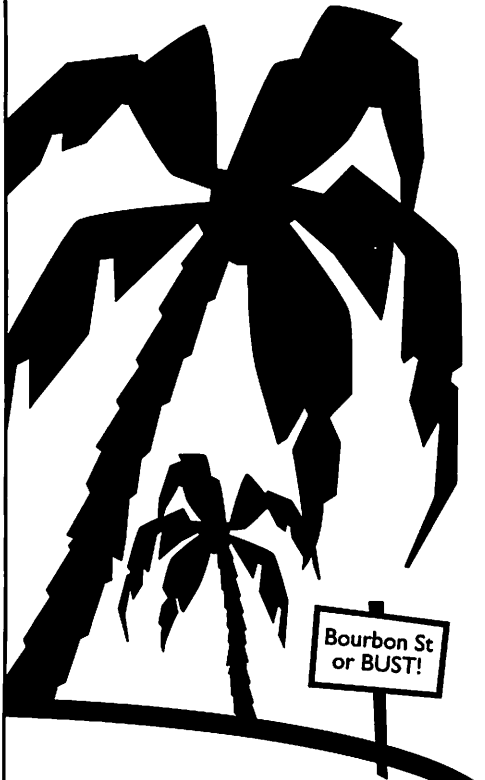

SCIRA Mid-Winter Championship

March 10-11, 5 races

Gulf of Mexico, Clearwater YC, Clearwater FL

Contact: **Bob Foster**, 830 S. Bayway Blvd., Clearwater, FL 33767 phone: 727/447-6000

Don Q Rum Keg

March 13-14, 5 races

Biscayne Bay, Coconut Grove SC, Miami, FL

Contact: **Gonzalo Diaz, Sr.**, 5520 SW 72nd Ave, Miami, FL 33155 phone: 305/667-0492

Bacardi & Gamblin Memorial Series

March 17-20, 2 series of 3 & 5 races

Royal Nassau SC, Nassau, Bahamas

Contact: **Peter Christie**, PO Box N-1628, Nassau, Bahamas fax: 242/326-5642
local housing available

U.S. Pan American Trials

Only open to U.S. Sailors, winner to represent the U.S. in the Pan American Games.

March 23 - 27, 6 races

Lake Pontchartrain, Southern YC, New Orleans, LA

Contact: **Watt Duffy**, 1201 Smith Drive, Metairie, LA 70005 phone 504/833-3919

The Zimmerman Perpetual Trophy, emblematic of the Winter Circuit Championship, will be awarded at the conclusion of the Circuit in Nassau.





Where do you want to go this summer?

FREE DRINK COUPON
Redeemable at 1999 Snipe Nationals
Registration Only! (2 Per Boat)

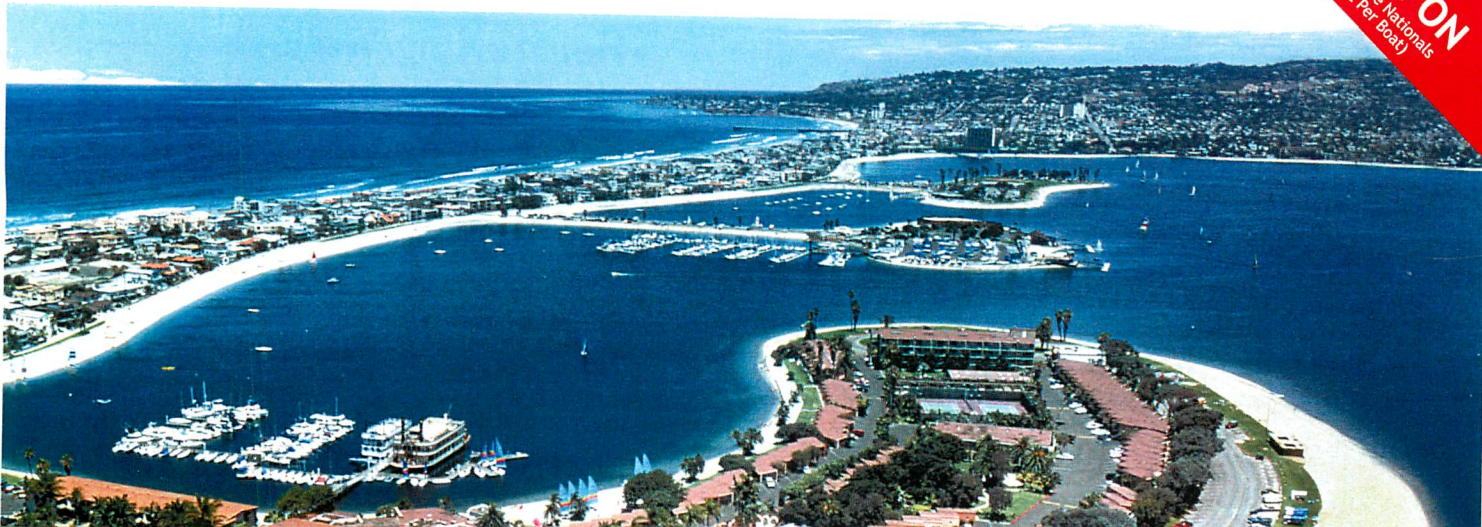

 **FREE COUPON**
Redeemable at 1999 Snipe Nationals
Registration Only! (2 Per Boat)



Mission Bay Yacht Club San Diego, CA

What does San Diego mean to you? We hope it means vacation. We hope it means "road trip." There will be bikes to ride, boards to surf, sun to soak up, steady breeze, and memories forever. Sail in the bay if you want, or try the ocean. Does it sound like Club Med yet? Hope so.
Come for the fun...stay for the regatta!

- **Womens-July 24-25**
- **Juniors- July 24-25**
- **Crosby-July 26-27**
- **Heinzerling/Wells-July 28-30**

- Sat. Pizza/cocktails
- Sun. Trophy & welcome
- Mon. Elms Fish Fry
- Tues. Surf Safari
- Wed. Dinner at SD Zoo
- Thurs. General Meeting/BBQ dinner
- Fri. Trophy dinner

- Stay for the World famous GFU 24 Hour Regatta July 31-August 1
- Info: www.snipe.org or call Regatta Chairman: George Walker, 619-226-4676

The Snipe Bulletin

The Official Publication of the
International Snipe Class



February/March 1999

Volume XVIII No. 2

Editor

Jerelyn W. Biehl

Editorial & Business Office

Address all correspondence to:
1833 Tustin Street, San Diego, CA
92106 USA Phone: (619)224-6998
Fax: (619)224-6997
Electronic mailing list:
snipe-list@snipe.org
Internet address: scira@snipe.org
www.snipe.org

POSTMASTER: Send address changes to
SNIPE BULLETIN, 1833 Tustin Street
San Diego, CA 92106 USA

Printed in the USA in San Diego, CA
by Modern Printing & Mailing

S.C.I.R.A. OFFICERS

Commodore

Lee Griffith
16 Orchard Way
Yardley, PA 19067
Griff27054@aol.com

Vice Commodore

Id Crook
6 John Street, Apt. 1002
Oakville, Ontario
Canada L6K 3T1
edhappy@idirect.com

Rear Commodore

Bertel Bojlesen
497 Livingood Lane
Lake Oswego, OR 97034
bertelb@hevanet.com

Executive Director

Jerelyn W. Biehl
1833 Tustin Street
San Diego, CA 92106
scira@snipe.org

RULES COMMITTEE

Chairman: Brainard Cooper
176 Ridge Avenue
Chattanooga, TN 37404
BCoop@voy.net

Publication Information

SNIPE BULLETIN (ISSN 08996288) is
published 10 times a year for \$10.00 per year
by Snipe Class International Racing
Association, Incorporated (not for profit),
1833 Tustin Street, San Diego, CA 92106
USA. Periodicals postage paid at San Diego, CA.
The Snipe silhouette and the International
Snipe Class crest are Trademarks of the Snipe
Class International Racing Association.

COMMODORES COMMENTS

Be an Ambassador for the Class...

For many parts of the Snipe world, this is the time of year to prepare for another sailing season. This will be a very big year for SCIRA. The 1999 Snipe Class World Championships will be held in Santiago de la Ribera, Spain in September. The Junior World Championships are also being held in Spain during the month of August. The European, South American, and North American Championships are all being scheduled and organized, and regional regatta schedules are being carefully constructed.

Typically, SCIRA governors, fleet captains, and other volunteers conduct key meetings and complete SCIRA business at these major championships and the majority of SCIRA work is accomplished this way. While this works well and will continue, there are also drawbacks. SCIRA governors are also sailors and competitors and there is a regatta schedule going on. The SCIRA meetings are competing for time with the competitive schedule and social events. The result is that there is not always the amount of time we would all want for careful discussion and study of issues and actions at these meetings. This is the reason that much SCIRA Board of Governors business is executed throughout the year on a quarterly agenda of business issues. The SCIRA Board of Governors is, in fact, a "working" board with board motions being brought forward and acted on throughout the year.

This past month, through the hard work and instigation of two past commodores of SCIRA, Buzz Levinson and Terry Timm, a productive SCIRA meeting was held in Atlanta, Georgia. The attendees composed a virtual braintrust of SCIRA past commodores, board members, US district governors, and interested Snipe sailors. Snipe boat builders and sailmakers were also invited to understand their viewpoints and perspective. All attendees devoted a weekend of their time to focus

on the relevant issues facing the Snipe class today (Thankfully it rained all weekend so this group of sailors didn't have to wistfully stare at the beakoning puffs on a sunny Allatoona Lake). The focused agenda covered issues such as boat, blade, and spar standardization; cost of new and used boats; the future of the Snipe Bulletin; restructuring of SCIRA membership and dues; better cooperation with boat builders and sailmakers; and how we can grow membership and promote the class. Based on the success of this meeting, I suggest that this event is repeated every other year and that similar meetings are held on each SCIRA continent with minutes sent to the SCIRA office.

The common theme of the weekend centered around how we can promote the class, grow membership, and continue to thrive in an evolving sailing world. There was much discussion about changing the boat in various ways. This discussion will continue and there are some things which should be done. It became clear, though, that the critical issues facing our future are not with the boat itself. The Snipe is a great boat as it exists today, although we will continue to evolve it slowly and carefully as SCIRA has in the past. SCIRA already has a great product to offer to the sailing world! The issue is how we package it and offer it to new potential customers in a volunteer organization with modest marketing budgets.

As we all watch the new sailing season evolve, I ask all SCIRA members to consider what you will individually do this year to be an ambassador for the Snipe class. We all must do our part to promote and market this great product that we all love. Everyone's ambassadorship will take a different form, but I ask everyone to do something individually to promote the Snipe class this year. Write to the Snipe Bulletin and tell us about it.

As a final teaser on the subject....what exactly are you and your fleet doing for World Snipe Day May 5th?

Commodore Lee Griffith

THE COVER: 1999 Brazilian Nationals with 74 entries, framed by the beautiful scenery of Rio de Janeiro. Hector Echebaster photo.

THE COUNT: 26 numbers were issued this month. 2 to Brazil; 10 to Japan; 4 to Italy; 1 to the US and 9 to Spain.

NUMBERED SNIPES: 29581

CHARTERED FLEETS: 849

SCIRA E-mail Information

Snipe Web Page: www.snipe.org

SCIRA Office: scira@snipe.org

Webmaster Alex Pline: pline@snipe.org

Request to subscribe to Snipe list: majordomo@snipe.org

In the body of the message type: subscribe snipe-list

To unsubscribe: majordomo@snipe.org

In the body of the message type: unsubscribe snipe-list

For information: info@snipe.org

To add a regatta to the web page: schedule@snipe.org

To send a message to the Snipe list: snipe-list@snipe.org

To send a message to the Int. Board: scira-int@snipe.org

To send a message to the US Board: scira-us@snipe.org

50th BRAZILIAN NATIONAL CHAMPIONSHIP

January 24 - 30, 1999

The 50th Brazilian National Championship was hosted by fleet 159 from the Iate Clube do Rio de Janeiro. As traditional the Fernando Avelar Trophy was raced on Sunday, 24 first day of the Championship as a more of "get to know the course" race. Sailing on the Guanabara Bay of the lovely Rio de Janeiro is a privilege, The Sugar Loaf and The Christ, with open arms welcoming all sailors. The winning team was: Leonardo Priolli and Eduardo Neves (the last World Champion crew). 74 Snipes signed up so the organising committee divided the fleet into 4 groups: yellow, white, purple and green. Each group sailed 6 races (one colour group against another) in 3 days, until after a drop race, the first 37 (half of the fleet) were classified as the Gold group and the rest as Silver group.

Day 1: The two first races started with an extremely hot day with winds of 12-15 knots, outgoing tide and high waves. The Race Committee made a very short starting line and several starts had to be made as most of the fleet had an early start. Both races were Olympic course.

Day 2: The day started hotter than ever, very mild winds so the Race Committee waited over 2 hours to start the first race. This time the starting line was longer, but not enough. When the first race started sailors were already tired of waiting. With winds at 8 - 10 knots the Race Committee chose a windward-leeward course. Day 3: Lots of clouds and less heat was the weather of the third day. Winds were good 10 to 12 knots. Both races were a windward-leeward course. The starting line was long enough (sailors comments) only one boat of both races had an OCS. The fish were flying over the Snipes, and Fernando Garrafa the Brazilian measurer "fished" one, and as in the evening the club offered a bar-b-q his dinner was guaranteed.. With these 6 results and a drop race, the fleet was divided into two groups: gold fleet and silver fleet. By now the leading team was: André Fonseca / Rodrigo Duarte followed by Paulo / Ricardo Santos and Ivan Pimentel / Rodrigo Lins.

Day 4: From now on the first start was for the gold fleet with the silver fleet starting 7 minutes later. The course chosen for the first race of the day was the Olympic one as winds were 15 to 18 knots. The tide was strong and many sailors had a certain difficulty in sailing. One of them was Kurt Diemer, the new Brazilian Snipe Constructor, who got to the first mark to realize that his skipper had fallen off the Snipea meter back and he was sailing alone. Ivan Pimentel, winner of the gold fleet of both

races that day, used all his skills and knowledge of being used to sailing in Rio and won the first race with a great advantage over the second. The winners of the silver fleet were: Bruno Motta/Bruno Gauer (a junior team) who won both races too.

Day 5: The 9th race was organised for this day. It was a difficult day for the sailors. The race committee took 2 hours to decide what kind of course, where to put the marks as the winds were not constant. Tempers were high and most of the sailors were starting to get really nervous. Finally the chosen course was the Olympic one and as the wind was mild and with the tide, slowly going out, the race was over in one hour. The winners were: gold fleet Andre Fonseca, silver fleet again Bruno Motta. Day 6 and last day: By this time Andre Fonseca had one point less than Ivan Pimentel so it was going to be The D Day. Nothing worked. First the winds were strong coming from the north-west and which meant having a start against the outgoing tide so the race committee decided to postpone and wait at the club. After over one hour the wind had changed to south-east

the Race Committee went out and so did most of the sailors. As most of the sailors reached the course, the weather changed, winds started to blow strong, over 30 knots. Those who were out on the course went for shelter. Sometime later the wind stopped blowing. With no conditions to sail and no more time, the race committee had no other option and cancelled the race. As some were being brought in by some rescue boats another storm approached. It is the third time in a row that there is a storm and damage to Snipes on the last day of the Nationals. We hope it is not going to become a tradition.

In the evening the Iate Clube do Rio de Janeiro hosted a memorable party, good food, lovely prizes and the best - a dance which went late into the night, everybody having great fun and relaxing after a week of tense races.

--Celia Garrafa

Top Results:

Gold Fleet:

1st Andre Fonseca/ Rodrigo Duarte
2nd Ivan Pimentel/Rodrigo Lins
3rd Paulo Santos/Ricardo Santos
4th Bruno de Amorim/Eduardo Rodrigues
5th Roberto Paradede/Daniel Ortega

Silver Fleet:

1st Bruno Motta/Bruno Gauer
2nd Pablo Furlan/Piero Furlan
3rd Francisco Vianna/Helio de Aquino Jr
1st Roberto Paradede/ Daniel Ortega
2nd Frederico Vasconcellos /Pedro Mascarenhas
3rd Marcos Mascarenhas / Pedro Caldas

Junior :

Master:

1st Paulo Santos/Ricardo Santos
2nd Bibi Juetz/Fernando Krahe
3rd Henrique Motta/Jorge Bueno

Ladies Team:

1st Caroline Bejar/Renata Veiga
2nd Mariana Teixeira/Simone Dani
3rd Vivian Mac Knight/ Nina Morgado

Mixed Team:

Jose Paulo Barcellos/ Amanda Dias
2nd Carlos Chaves / Virginia Almeida
3rd Mario Simoes/Deborah Wilcox

Teen Team:

(born after
1982)

1st Rafael Lima/ Bernardo Mulhbauer
2nd Michel Weber/ Flavio Scherer
3rd Felipe Chaves/ Affonso Chaves Neto



UK News

**The Old Fox
Leslie Lancaster
Retires at 91**

1999 sees the retirement from active Snipe competition of a 91 year old UK member, Leslie Lancaster. Whilst Leslie retains his deep support and interest in the Class, plus, assures all that where and when it becomes necessary his opinion and argument shall still be voiced to both defend and progress SCIRA.. he is far from over the hill.

Holder of many titles in championship racing the one title and nickname sums up this very wily sailor... "The Old Fox". Leslie has served on numerous SCIRA UK committee's, held for three separate terms as Fleet Captain of the Maldon fleet and also undertaken most offices in Maldon Yacht Club, inclusive of Commodore.

Although Leslie talks of retirement and sold his beloved Snipe *Marnie*, it has been noticed on the Maldon Yacht Club notice of 1999 "crews available" there is top of the list the name Leslie Lancaster...

--John Broughton



photo above: Leslie Lancaster with John White, Maldon Fleet Captain. Photo was taken in October 1998 at Leslie's last championship race - the British Snipe South Eastern Championship, hosted by Maldon Yacht Club.



CONGRATULATIONS!



	Bra		Rus
	29112		29106
Bra	1	Rus	
27390		29106	
	2		3

WORLD CHAMPIONSHIP 97
You did it again, again and again!!

Topsailors using Persson Snipe placed:

**1, 2, 3, 4, 5, 6, 7, 8, 10, 11,
13, 14, 15, 16, 17, 18, 19, 20.....**

- **No computer - just experience.**
- **New 98 version - still improving.**
- **Complete snipes or bare hull options.**
- **Masts and equipment:**
 - Proctor "Miracle" Euro (2,3,4 and 6 W.C.)
 - New Proctor "Vectis" (March 98)
 - Sidewinder "Cobra"
 - Sidewinder "Junior" (1 and 5 W.C.)
- **Worldwide distribution and sale.**

<p>Noel Ferreira Phone: +55 - 21 620 1542 Fax: +55 - 21 516 3679 BRASIL</p>	<p>Diego Cuenca Phone: +34 - (9)68 18 32 11 Fax: +34 - (9)68 18 40 91 SPAIN</p>	<p>Masahito Tsuchida Phone: +81 - 3 5380 1218 Fax: +81 - 3 5380 1158 JAPAN</p>
<p>Jack Franco Phone: +1 - 310 767 1032 Fax: +1 - 310 767 1034 USA</p>	<p>Birger Jansen Phone: +47 - 66 84 95 09 Fax: +47 - 66 84 82 62 NORWAY</p>	<p>Gilles Boisaubert Phone: +33 - 1 48 86 68 75 Fax: +33 - 1 48 86 68 75 FRANCE</p>
<p>DESIGN AND PRODUCTION PERSSON MARINE Strandvejen 352 C, DK-3060 Espergærde DENMARK Phone: +45 - 49 17 02 10 Fax: +45 - 49 17 06 20</p>		<p>LICENSE BUILDER Claudio Barbieri CANTIERI NORDEST Phone: +39 - (0) 444 350 667 Fax: +39 - (0) 444 350 667 ITALY</p>

The Strategy of SCIRA Europe

Many people ask me; what will you do as the new SCIRA European Secretary? Good question! I can answer like this: develop the class; bring young people to the Snipe.. but this is basic and obvious!

The first item is to develop SCIRA Europe. Currently rules pertaining to SCIRA Europe don't exist. So, following the plan originally conceived by Antonio Roquette, I have proposed an amended European Statute. This will provide Europe with some administrative rules and guidelines. For example, the election of the European General Secretary, Northern and Southern Secretaries and the other European officers; meeting schedules and other items pertaining to the administration of SCIRA Europe. This work is currently in progress and I hope the new European Statute can be approved at the 1999 Snipe Worlds. There are some rumors that the Europeans seek to divide themselves from the rest of SCIRA. This is absolutely false! We all work together and work well as SCIRA International to keep our Class strong around the world.

The second step is to produce the European calendar. Normal? Not this year! It's the first time that we actually have a European calendar. My goal is to increase the

exchange of regattas between the different countries. Our European Championship is held in even numbered years. What do we do in the odd numbered years? Only a few crews from each country go to the Worlds, but it should be important to find other competitions for competitors for those not attending the Worlds. Currently we have the European Cup and the Northern and Southern European Championships. We must find a way to increase participation at these regattas.

We also have to look at the European Championship. This event must become more important in the sailing world, as we need more attendees, we need better race committees and we need better organization. In the last two European Championships, for example, the race committees didn't follow the SCIRA rules. SCIRA Europe must be very strong to ensure compliance of our rules at championship regattas. We also have a Junior European Championship in which we must also place increased importance.

Today SCIRA is represented in many European countries, but this is not enough. We must increase our strength in important countries like Germany. And we have opportunities in all the countries of Eastern! In many of these countries the Snipe is the ideal boat.

We must market the Snipe through exposi-

tions, advertising and newspapers and promote the Class in Europe from the junior to the National Sailing Federation levels.

So you see, we have a full agenda and we are open to your ideas and input. We have a good team in the European officers; André Callot, Vice Euro Secretary; Pedro Pons, Southern European Secretary; Ola Nygard, Northern European Secretary and Alexei Fomin, Eastern European Secretary. These gentlemen have a wealth of ideas and are ready to work for the Class, so I believe you will be hearing from Europe in the coming year!

Ezio Braga
European General Secretary
braga@galactica.it

The Tradition Continues...

✈ Sails	1st 1997 Gamblin Series/Winter Circuit
✈ Covers	2nd 1997 U.S. National Championships
✈ Masts	3rd 1997 District 6 Championships
✈ Booms	1st U.S. Finisher (3rd Overall) 1996 Western Hemispheres
✈ Rigging	3rd & 4th 1996 U.S. Nationals

Featuring our Mylar Mag2 jib with glued seams, no stitching!

For more information on our sails, please contact us at:

Ullman Sails

410 - 29th Street
Newport Beach, California 92663
Phone - 714/675-6970
Fax - 714/675-6276
Email - ullman@ullmansails.com



SEITECH Launching Dolly

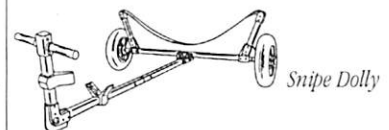

Snipe Dolly

Ideal for launching, moving, and storing your boat. Light, strong, corrosion-proof, maintenance-free. Aluminum frame, engineered plastic joint components, stainless steel fasteners, 3"-wide sling, and pneumatic ATV wheels with plastic rim & Delrin needle bearings. Rolls easily over sandy and rocky beaches.

Comes as a kit. Easy to assemble, no-tool breakdown into 3 pieces. UPS shippable. One year warranty.



*Choose our
16 x 6, 9.5 x
19, or 11 x 22
ATV Wheels.*

We've got a dolly for any dinghy!

SEITECH Marine Products, Inc.

PO Box 514, Portsmouth, RI 02871 USA

Tel: 401-683-6898, Fax: -6897

E-Mail: Sei52@aol.com Web: www.seitech.com



1999 Officers Directory

Flag Officers

Commodore - Lee Griffith, 16 Orchard Way, Yardley, PA 19067 USA, telephone: +215-321-5754, fax: +215-321-5954, e-mail: Griff27054@aol.com

Vice Commodore - Id Crook, 6 John Street, Apt. 1002, Oakville, Ontario, Canada L6K 3T1, telephone: +905-842-7949, fax: +905-842-3953, e-mail: edhappy@idirect.com

Rear Commodore - Bertel Bojlesen, 497 Livingood Lane, Lake Oswego, OR 97034 USA, telephone: +503-699-0998, work/fax: +503-675-8609, e-mail: bertelb@hevanet.com

Past Commodore - Akibumi Shinoda, 6-25 Kamezaki Takane-cho, Handa-City, Aichi, Japan 475, telephone: (h)+81-569-28-4294, fax: +81-566-27-5678, e-mail: Shinoda@toyota-shokki.co.jp

Rules Chairman Emeritus: Dan Williams

Executive Director – SCIRA Office

Mrs. Jerelyn Biehl, 1833 Tustin Street, San Diego, CA 92106, USA, telephone: +619-224-6998, (f)+619-224-6997, e-mail: scira@snipe.org, Web page: www.snipe.org

Board of Governors

Rules Committee Chairman - Brainard Cooper, 176 Ridge Avenue, Chatta nooga, TN 37404 USA, telephone: +423-622-6081, fax: +423-624-0300, e-mail: Bcoop@voy.net

European General Secretary - Ezio Braga, via Bellingeria 3, I21052 Busto Arsizio, Italy, telephone: +39-0331-667-037, fax: +39-0331-620-422, mobile: +39-335-287810, e-mail: Braga@galactica.it

Vice Secretary, Europe - André Callot, Lege Veldkantlaan 30, 2540 Hove, Belgium, telephone: (h) +32-3-455-0231, fax: +32-3-457-8120

Secretary, Southern Europe - Pedro Pons Morales, Paseo del Puerto s/n, 07760 Ciudadela, Menorca, Spain, telephone: (h)+349-71-380853, fax: +349-71-384-330, e-mail: ppons@infotelecom.es

Secretary, Northern Europe - Ola Nygard, Smalgangen 30, N0188 Oslo, Norway, telephone: (h)+47-22-17-8887, fax: +47-22-42-3494, e-mail: ola.nygard@steenstrup.no

Western Hemisphere General Secretary - Don Hackbarth, 2350 Willeo Rill Rd., Marietta, GA, 30062 USA, telephone: (w)+770-395-2800, fax: +770-395-2801, e-mail: snipesgwh@aol.com

Vice Secretary, Western Hemisphere - Celia Garrafa, Rua João de Sousa Dias 983 Apt 101, 04618-003 São Paulo, SP Brazil, telephone: +55-11-533-6291, fax: +55-11-241-9558, e-mail: fgarrafa@tpn.com.br

Treasurer - Member at Large 1998-2000 - Fred Rozelle, 850 N. Oxford Road, Grosse Pointe Woods, MI 48236 USA, telephone: (h)+313-882-3533, fax: +248-362-2903, e-mail: frozelle@bdo.com

Member at Large 1998-2000 - Francisco "Pancho" Jose Agusti, Lincoln 47, 5152 Villa Carlos Paz, Cordoba, Argentina, telephone: +54-541-32-444, fax: +54-541-32-220, e-mail: snipearg@satlink.com

Member at Large 1999-2001 - Birger Jansen, Broveien 44, 1315 Nesoya, Norway, telephone: +47-66-849-509, fax: +47-66-848-262

Member at Large 1998-2000, Terry McSweeney, 26019 Lake Road, Bay Village, Ohio 44140 USA, telephone: (w)+216-241-4420, (h)+216-892-1321, fax: +216-241-4424, tnl@mediaone.net

Member at Large 1998-2000 - Lori Lowe, PO Box N-918, Nassau, Bahamas, telephone: (h)+242-393-1730, (w)+242-322-4782, fax: +242-322-2048, e-mail: lorijim@100jamz.com

Member at Large 1999-2001 - Pedro Lorson, 27 Prospect Avenue, Port Washington, New York, 11050 USA, telephone/fax: (h) 516-944-3964, e-mail: pedrolorson@erols.com

US National Secretary - Jerry Thompson, 916 Palo Verde, Long Beach, CA, 90815 USA, telephone: (h)+562-596-5962, fax: +562-596-1490, e-mail: jtsnipe@usa.net

Non-Voting Board Members

Legal Counsel - Leigh Savage, 1032 North Brys Drive, Grosse Pointe Woods, MI 48236 USA, telephone: (h)+313-884-7929, (w)+810-777-0720, fax: +810-777-0727

ISAF Representative - Per Ole Holm, Oy Haro-Invest Ab, Niittykatu 6 Kakkola, 67100 Finland, telephone: (h)+358-6-831-1442 (apt. in Kakkola), (h)+358-6-728-5013 (summer) (w)+358-6-822-0098, fax: +358-6-822-0112, e-mail: po.holm@pp.kpnet.fi

Vice Chairman, Rules Committee - Giorgio Brezich, via Negrelli 12, Trieste, 34143 Italy, telephone: (h) +39-40-307-955, fax: +39-040-313-257

Secretary, Eastern Europe - Alexei Fomin, UL8 Marta Dom 2/10, Korpus 3, KV 30, Moscow 125083, Russia, telephone/fax: +70-95-924-10-19, e-mail: sail@mol.ru

ARGENTINA: Francisco Jose Agusti, Lincoln 47 5152 Villa Carlos Paz Cordoba, Argentina telephone: +54-541-32-444 fax: +54-541-32-220 e-mail: snipearg@satlink.com

BAHAMAS: Peter Christie, PO Box N1628 Nassau, Bahamas Fax: +242-326-5642 e-mail: bswestbrook@hgchristie.com

BELGIUM: Andre Callot, Lege Veldkantlaan 30 2540 Hove, Belgium telephone: (h)+32-3-455-0231 fax: +32-3-457-8120

BERMUDA: Kevin Blee, PO Box HM1327 Hamilton, HMFx, Bermuda telephone: (h)+441-295-6165 fax: +441-296-8406 e-mail: kevinblee@proserve.bm

BRAZIL: Álvaro Fonseca, Jr., late Clube de Santa Catarina-Veleiros da Ilha Av. Silva Jardim 212, Prainha Florinopolis, SC Brazil, 88020-200 fax: +55-48-282-12-98 e-mail: icsevi@floripa.com.br

CANADA: Id Crook, 6 John Street, Apt. 1002 Oakville, Ontario, Canada L6K 3T1 telephone: (h)+905-842-7949 fax: +905-842-3953 e-mail: edhappy@idirect.com

CHILE: Jorge González, Paris N 824 Santiago, Chile fax: +56-2-638-3440

COLOMBIA: Mariana de Isaza, Diagonal 126A#59-42 Bogota, Colombia telephone: +57-1-253-1212 fax: +57-1-245-1220 e-mail: elytefce@openway.com.co

CUBA: Vicente de la Guardia, Federacion Cubana de Vela Club Nautico Internacional Hemingway Ciudad de Habana, Cuba fax: +537-241-689 e-mail: admin@inder.get.cma.net

DENMARK: Henning Sørensen, P.U. Bruuns Vej 40 DK 5600 Faaborg, Denmark telephone: (h) +45-626-1-8801 (w)+45-626-3-1091 fax: +45-626-3-1607 e-mail: hs@ken.dk

FINLAND: Sampo Valjus, Koskitie 47 B8 FIN90500 Oulu, Finland telephone: (h) +358-8-554-38-35 fax: +358-8-311-22-19 e-mail: sampov@asava.pp.fi

FRANCE: Phillippe Roy, 60 Rue de Longchamp 75116 Paris, France telephone & fax: +33-1-47-27-14-52

GERMANY: Ben Van Cauwenbergh, Rheingau Str. 9 65375 Oestrich-Winkel Germany telephone & fax: +49-6723-1701

INDIA: Dr. M. Gunasheela, Bangalore Sailing Club 45 Central Street Bangalore 560001, India telephone: +91-80-564-210 fax: +91-80-528-3754

ITALY: Ezio Braga, via Bellingeria 3 I21052 Busto Arsizio, Italy telephone: +39-0331-677-037 fax: +39-0331-620-422 e-mail: ezio.braga@galactica.it

JAPAN: Jiro Yamamoto, 902 Neomaimu Tsurumi Riverside 5-11-12 Tsurumi-Chuoh, Tsurumi-Ku Yokohama, Japan 230 telephone/fax: +81-45-507-2856 work fax: +81-45-505-7617 e-mail: yamamoj@eng.tsurumi.nkk.co.jp

NORWAY: Birger Jansen, Broveien 44 1315 Nesoya, Norway telephone/fax: +47-66-849-509

PORTUGAL: Miguel Bunte da Graça, Quinta Grande, 28D 2720 Alfragide, Portugal telephone: +35-11-471-3499 fax: +35-11-471-3503

RUSSIA: Alexei Fomin, UL 8 Marta Dom 2/10 Korpus 3, KV 30 Moscow 125083, Russia telephone/fax: +70-95-924-10-19 home telephone/fax: +70-95-414-8930 e-mail: sail@mol.ru

SPAIN: Ricardo Rubio Vilar, Avenida del Puerto s/n, PO Box 155 30740 San Pedro del Pinatar Murcia, Spain telephone: +34-9-68-18-79-14 fax: +34-9-68-18-40-91 e-mail: snipe@arrakis.es

SWEDEN: Karin Petterssen, Blackevägen 21 S41716 Gothenburg, Sweden telephone: (h)+46-31-508-592 fax: +46-31-137-535 e-mail: scira.sweden@swipnet.se

SWITZERLAND: Arlette Jan, 87 Rue de Lausanne, Attic Geneva CH 1202 Switzerland telephone: +41-22-738-6332 fax: +41-22-734-8877

UNITED STATES: Jerry Thompson, 916 Palo Verde Long Beach, CA 90815 telephone: (h)+562-596-5963 fax: +562-596-1490 e-mail: jtsnipe@usa.net

UNITED KINGDOM: John Love, 8 Pasture Drive Croft, Warrington Cheshire, England WA3 7LH telephone & fax: +44-1925-764-156

URUGUAY: Pedro Garra, Rufino Bauza 2489 11300 Montevideo, Uruguay telephone: +59-82-709-1320 fax: +59-82-916-3315 e-mail: pgarra@chasque.apc.org

International Rules Committee

Rules Committee Chairman - Brainard Cooper, 176 Ridge Avenue, Chatta nooga, TN 37404 USA, telephone: +423-622-6081, fax: +423-624-0300, e-mail: Bcoop@voy.net

Vice Chairman, Rules Committee - Giorgio Brezich, via Negrelli 12, Trieste, 34143 Italy, telephone: (h) +39-40-307-955, fax: +39-040-313-257

Chief Measurer - Hisanao kato, 2-14-1 Komimachi, Komae-city, Japan 201, telephone & fax: +81-03-3489-1057, e-mail: hiskato@ibm.net

Antonio Bari - Via Vittorio Veneto #24, 38100 Trento, Italy. Telephone: +39-461-913001, (f)+39-461-236781, e-mail: bari@tqs.it

Dina Kowalshyn, 125 Severn Drive, Annapolis, MD 21401

Ron Fox, 2131 Tevis Avenue, Long Beach, CA 90815

Johnny MacCall, Arenales 2186, 1640 Buenos Aires, Argentina, telephone: +54-114-792-7152

U.S. Fleets and Fleet Captains

Based on listings in the SCIRA Office as 2/20/99. Please contact the SCIRA Office with corrections.

Note: phone numbers listed are residence.

ALABAMA

Birmingham - #828 - Mike Neilson, 723 Linwood Road, Birmingham, AL, 35222
205-591-8683

CALIFORNIA

Alamitos Bay - #218 - Todd Smith, 24 Via di Roma Walk, Long Beach, CA
90803, 562-433-6686; trsmith@ccgate.hgc.com
Lake Washington - #043 - David Lemoine, 5135 Glide Dr., Davis, CA 95616,
530-792-1505, snipelee@mindspring.com
Mission Bay - #495 - Gavin O'Hare, 4588 W. Pt. Loma Blvd, #A, San Diego, CA
92107, 619-225-0117, go'hare@nalco.com
Newport Harbor - #094 - Steve Kimble, 20582 Pebble Lane, Huntington Beach,
CA 92646, 760-963-4960
Redwood Empire - #654 - Robert Hunt, 901 Alice Avenue, Ukiah, CA 95482,
707-462-7627
San Francisco Bay - #012 - Joe Harvard, 10 Liberty Ship Way, Suite 208,
Sausalito, CA 94965. 415-289-3980, joe@partnersindesign.com

COLORADO

Bow Mar - #640 - Steve Tautz, 4505 W. Wagon Trail, Littleton, CO 80123, 303-
794-0385
Rocky Mountain - #210 - Doug Swenson, 605 East 9th Avenue, Denver, CO
80203, 303-863-0566

CONNECTICUT

Quassapaug - #231 - Shane Erickson, 15 Coventry Lane, Naugatuck, CT 06770,
203-729-1258, serickson@sjassoc.com

FLORIDA

Miami - #007 - Gonzalo Diaz, Sr., 5520 SW 72nd Avenue, Miami, FL 33155,
305-667-0492
St. Petersburg - #801 - Bill Welch, P.O. Box 2154, St. Petersburg, FL 33731,
813-821-0900, sails@intnet.net

GEORGIA

Atlanta - #330 - Doug Cleveland, 700 Babbling Creek Place, Alpharetta, GA
30302
Lake Lanier - #781 - Nancy Gilreath, 8055 Innsbruck Dr., Atlanta, GA 30350,
770-512-0565, ngilreath@kilstock.com

ILLINOIS

Carlyle Lake - #705 - Richard C. Brown, 1520 Woodbridge Crossing Dr.,
Chesterfield, MO 63005, 314-536-2826
Island Bay - #091 - Lou Dixon, 2040 Wiggins, Springfield, IL 62704, 217-793-
3359

INDIANA

Eagle Lake - #145 - Lloyd Ketchum, Jr., 1129 Riverside Drive, South Bend, IN
46616, 219-232-8740
Indianapolis - #409 - Frank Workman, 1179 Westminster Way, Carmel, IN
46033, 317-844-7685

IOWA

Iowa Nebraska - #309 - Peter Festersen, 900 Farnham St., #505, Omaha, NE
68102, 402-346-8187. Pfesteren@accessOmaha.com

KANSAS

Quivera - #121 - Joe Bartels, 161 Lakeshore South, Lake Quivera, KS 66106,
913-268-6370
Wichita - #093 - Mary Ann Rix, 1054 Gretchen Lane, Wichita, KS 67206, 316-
684-6086

LOUISIANA

New Orleans - #116 - Watt Duffy, 1201 Smith Dr., Metairie, LA 70005, 504-833-
3919, TheBunnMan@msn.com

MASSACHUSETTS

Medford - #777 - Chuck D'Antonio, 48 Forest St., #207, Medford, MA 02155,
781-393-6840
Winchester - #077 - Harry Levinson, 3 Sachem Rd., Winchester, MA 01890, 781-
721-9255

MARYLAND

Annapolis - #532 - Alex Pline, 305 Monterey Ave., Annapolis, MD 21401, 410-
263-8457, pline@snipe.org

MICHIGAN

Barton Boat Club - #520 - Matt Heywood, 3237 Homestead Commons Dr. Apt.
4, Ann Arbor, MI 48103. 313-662-7536
Detroit River - #005 - Brad Valka, 20910 Lennon, Harpers Woods, MI 48225.
313-331-7826
Grand Rapids - #137 - Rich Grant, 141 Gleneagle Dr., Rockford, MI 49341, 616-
866-3569
Gull Lake - #190 - Dave Johnson, 1262 Burlington, Hickory Corners, MI 49060,
616-731-5845
Wolf Lake - #141 - John Crookston, Rt. 2 11925 Scotts Pk Rd., Delton MI 49046.
616-671-4303

MISSOURI

Lake Lotawana - #049 - Doug Day, 6719 NW Willowick Lane, Parkville, MO.
64152, 816-746-4899
Kansas City - #824 - Jim Downs, 7525 Arlington, Raytown, MO 64138. 816-
356-5338

MISSISSIPPI

Magnolia - #604 - Joe Buzhardt, 1385 Narrow Gauge Rd., Bolton, MS 39041,
601-852-2238

NEBRASKA

Iowa-Nebraska - #309 - Peter Festersen, 900 Farnham St., #505, Omaha, NE
68102, 402-346-8187. Pfesteren@accessOmaha.com
Lincoln - #567 - Charles Wahl, 307 Taylor Park Dr., Lincoln, NE 68510, 402-
489-5950, cwahl@les.lincoln.ne.us

NEW JERSEY

Barneget Bay - #256 - Dave Applegate, 118 Laurel Avenue, Toms River, NJ
08753, 908-505-1825
Lake Mohawk - #010 - Jeff Urbanski, 63 Woodlawn Rd., Sparta, NJ 07871, 201-
729-3324

NEW YORK

Chautauqua - #124 - Mick Yates, 7 Packard Garden, Lakewood, NY 14750, 716-
763-8736
Cuba Lake - #442 - Leo Murphy, PO Box 66, Cuba, NY 14727, 716-372-2853
Galway - #412 - John Korkosz, 71 Baldwin Rd., Glenville, NY 12302, 518-399-
6597
Newport Yacht Club - #103 - Ted Horvath, 496 Smith Rd., Pittsford, NY 14534,
716-624-2101, tforvath@worldnet.att.net
Onondaga - #018 - E.F. Booth, 7471 Thunderbird Road, Liverpool, NY 13088,
315-457-7751
Sea Cliff - #004 - David Lawson, 76 Wyatt Road, Garden City, NY 11530, 516-
742-2574

OHIO

Acton Lake - #515 - James Hater, 230 Solarama Court, Cincinnati, OH 45238,
513-451-1705
Chippewa - #621 - Dennis Mizerak, 4770 Locust Lane, Brunswick, OH 44212,
330-273-3638
Cleveland - #747 - Mike Delaney, 796 Hoover Rd., Cleveland, OH 44119, 216-
486-1862
Cowan Lake - #433 Bob Whitman, 8323 Old Hickory Dr., Cincinnati, OH 45243
513-793-3771
Hoover - #760 - Bill Clawson, 42 E. Stanton Ave., Columbus, OH 43214
Portage Lakes - #110 - Roger Ream, 679 Market St., Akron, OH 44303, 216-
864-1117



OKLAHOMA

Oklahoma City - #014 - Andy Towles, 611 Joni Deanne Ct., Edmond, OK 73034, 405-359-0128

Sequoyah - #068 - Steve Snider, 1445 Yorkton Ln., Bartlesville, OK 74006, 918-333-6538

OREGON

Willamette - #533 - Jim Lampros, 925 Wilbur Street SE, Salem, OR 97302, 503-364-3982

SOUTH CAROLINA

Charleston - #052 - Steve Burns, 689 Wildwood Drive., Charleston, SC 29412, 803-795-3682

TENNESSEE

Memphis - #407 - W.I. Longworth, 4699 Normandy Avenue, Memphis, TN, 38117, 901-685-1767

Privateer - #142 - Holly Gregory, 7743 Village Way Drive, Hixson, TN 37343, 615-842-5045

TEXAS

Dallas - #001 - Jerry Sams, 1109 Pittsburg Landing, Richardson, TX 75080, 214-783-1314

WASHINGTON

Seattle - #444 - Jim Miller, 15823 27th Ave NE, Seattle, WA 98155. 206-365-5319, jmi4039420@aol.com

WISCONSIN

Green Lake - #129 - Mary Jane Bumby, PO Box 3, Green Lake, WI 54941, 920-294-3300

1999 US Regatta Schedule

as of 2/20/99

call District Governor for those not listed

District 1

May 22-23	Blue/Grey	Island Heights, NJ
June 5-6	Districts/Colonial Cup	Annapolis, MD
June 26-27	Whittemore/St. John	Lake Quassapaug, CT
July 10-11	Winchester Invitational	Winchester, MA
August 14-15	Down Bays	Little Egg Harbor, NJ
August 28-29	Board of Governors	Lake Quassapaug, CT
September 11-12	NJ State Champs	Surf City, NJ
September 17-19	North Americans	Cottage Park, MA
September 25-26	Mystic Lake Open	Medford, MA
October 16-17	Frigid Digit	Annapolis, MD

District 2

March 23-17	US Pan Am Trials	New Orleans, LA
May 29-30	SouthWesterns	Dallas, TX
June 19-20	District Champs	Lincoln, NE
July 3-4	Missouri Valley	Omaha, NE
July 10-11	Norm Tanner	Bow Mar, CO
August 14-15	Rocky Mountain	Grand Lake, CO
September 4-5	2000 Nationals Warm-up	Oklahoma City, OK
September 18-19	Ramel Williams	Lake Lotawana, MO

District 3

June 5-6	Cowan Lake	Cowan Lake, OH
June 12-13	District Champs	Columbus, OH
June 19-20	Barton Pond	Ann Arbor, MI
June 26-27	Governor's Cup	Springfield, IL
July 10-11	Michigan Open	Grand Rapids, MI
July 17-18	Gull Lake Regatta	Gull Lake, MI
September 11-12	Indiana Open	Indianapolis, IN
September 13-16	US Masters	Indianapolis, IN
September 25-26	Carlyle Regatta	Carlyle, IL

District 4

March 10-11	Midwinters	Clearwater, FL
March 13-14	Don Q Rum	Miami, FL
April 17-18	AYC Invitational	Atlanta, GA
May 8-9	Southern	Privateer, TN
May 22-23	District Champs	Lake Lanier, GA
July 31-August 1	Southeastern	Lake Lanier, GA
September 11-12	Florida Jr. Champs	Miami, FL
September 11-12	Battle of Atlanta	Lake Lanier, GA
October 30-31	Halloween	Atlanta, GA
November 27-28	Florida State Champs	St. Pete, FL

District 5

July 10-11	New York State Open	Chataqua, NY
July 24-25	District Champs	Cuba, NY
August 14-15	Briody Regatta	Newport, NY

District 6

March 27-28	Olympic Classes Regatta	Alamitos Bay, CA
April 24-25	Herb Shear Memorial*	Mission Bay, CA
May 29-30	Memorial Day*	Alamitos Bay, CA
July 10-11	District Champs*	Mission Bay, CA
July 31-August 1	24 hour Regatta	Mission Bay, CA
October 2-3	Lake Cachuma*	Santa Barbara, CA
October 30-31	Carolyn Nute Memorial*	Mission Bay, CA
November 20-21	Turkey Day	Alamitos Bay, CA
December 11-12	Hot Rum	Mission Bay

*traveling trophy regatta

District 7

March 7	Midwinter #4a	Richmond, CA
March 13-14	Spring Regatta	St. Francis YC, CA
March 14	Midwinter #4b	Lake Merrit, CA
April 3	Spring Regatta	Richmond, CA
April 17	Flatwater #1	Encinal, CA
May 1	Flatwater #2	Encinal, CA
May 15-16	Spring Regatta	Lake Washington, CA
June 12	Flatwater #3	Encinal, CA
June 19-20	Districts	Clear Lake, CA
July 17	Flatwater #4	Encinal, CA
August 7	Flatwater #5	Encinal, CA
August 14-15	PCCs/Al Morris	Yale Lake, WA
August 28	Flatwater #6	Encinal, CA
September 25-26	Nor Cal Open	Richmond, CA
October 23-24	Fall Classic	St. Francis YC, CA
November 20	Turkey Shoot	Lake Washington, CA

U.S. District Governors

- District 1:** Bob Coyle, 667 Main Street, Apt. 8, Woburn, MA 01801, 781-935-8130
- District 2:** Andy Towles, 611 N. Joni Deanne Ct., Edmond, OK 73034, 405-359-0128
- District 3:** John Sepanski, 102 Greenway Dr., Edwardsville, IL 62025, 618-656-3428, jsepanski@aol.com
- District 4:** John Hill, 1190 Winding Creek Trail, Atlanta, GA 30328, 404-252-8711, jjchill@solrdnet.att.net
- District 5:** John Korkosz, 71 Baldwin Dr., Glenville, NY 12302, 518-399-6598, jrct@aol.com
- District 6:** Jerome Fournier, 6616 Canyon Rim Rd #98, San Diego, CA 92111, 619-268-0925, jromfour@cts.com
- District 7:** Packy Davis, 8 Maple Ave., Atherton, CA 94027, 650-323-5588, Packy3rd@aol.com

SCIRA Major Regatta Schedule

1999 South American Championship

Algarrobo, Chile
Juniors: March 28-31
Seniors: April 1-4

1999 Junior World Championship

Almeria, Spain
August 17-21

1999 Northern European Championship

Harwich, United Kingdom
August 5-8

1999 Pan American Games

Gimli, Manitoba, Canada
July 25-31

1999 World Championship

Santiago de la Ribera, Spain
September 4-12

1999 North American Championship

Cottage Park, Maryland
September 17-19

US Major Regatta Schedule

1999 US Pan American Trials

March 23-27
New Orleans, LA
Lake Ponchartrain, Southern YC

1999 US National Championship

Junior, Women's and Senior
Mission Bay, California
Junior & Women's - July 24-25
Senior - July 26-30
Top 3 qualify for 2000 WH & O in Argentina

1999 US Masters Championship

Indianapolis, Indiana
September 13-16

1999 North American Championship

Cottage Park, Massachusetts
September 17-19

*Top US sailors qualifies for 2000 WH & O in Argentina
Top Jr. sailor qualifies for 2000 WH & O in Argentina*

1999 US District Championship Schedule

District 1: June 5-6 - Annapolis, MD
District 2: June 19-20 - Lincoln, NE
District 3: May 12-13 - Columbus, OH
District 4: May 22-23 - Lake Lanier, GA
District 5: July 24-25 - Cuba Lake, NY
District 6: July 10-11 - Mission Bay, CA
District 7: June 19-20 - Clear Lake, CA

1998 Snipe Champions

Trophy

Trophy	Winner
Masters World Championship	Bibi Juetz /Felipe Vasconcellos, Brazil
Roy Yamaguchi Women's World Championship	Ekaterina Skoudina /Tatiana Lartseva, Russia
European Championship Hayward Western Hemisphere	Aureliano Negrin /David Martin, Spain Eduardo Santambrogio /Gonzo Martinez, Argentina
Mills North American Champion	George Szabo/ Jeff Baker, USA
South American Championship	Ricardo Fabini /Saralegui, Uruguay
Junior European Championship	Gabriel Orfila /Arturo Barranco, Spain
Reichner High Point Trophy	Neil Martin, England

SCIRA National Champions

Argentina	Senior Junior Master Womens	Cristian Noé & E. Ezequiel González Ignacio F. Viñas & Lucas Gómez Julio Labandeira & Verena Zagni Adriana Lischeron & M.Zapia
Bahamas	Senior	Robert Dunkley & Lee McCoy
Bermuda	Senior	Mark Henneberger & Bob Petty
Brazil	Senior	Alexandre Paradedá & F. Fernandes
Canada	Senior	John Jackman & Steve Stewart
Chile	Senior	Sebastián Larrain & Juan Gacte
Colombia	Senior	Felipe Castillo & M.I. Astorquia
Denmark	Senior Junior	Preben Kristensen & Uffe Schmidt Otto Nielsen & Thomas Rasmussen
Finland	Senior	Ville Aalto-Set & Jussi Nevas
Italy	Senior	Gabriele Bernardis & Stefano Pontalti
Japan	Senior Junior Master Womens	J. Shiraishi & K. Sumita Shimada & Kanamori K. Kawakami & S. Omori K. Isobe & Y. Matsuura
Spain	Senior Junior Masters Womens	Aureliano Negrin & David Ruiz Gonzalo Morales & J. de la Cruz Felix Gancedo & Carlos Llamas Blanca Espinosa & R. Fernandez
Sweden	Senior Junior Masters Womens	Patrik Jönsson & Rickard Oberpichers Martin Wigfors & Johan Wigfors Tommy and Christina Sandberg Sofia Watz & Linda Johansson
United States	Senior Junior Masters Womens	George Szabo & Eric Wilcox Steve Hochart & Jonathan Boyd George & Greg Fisher Jennifer Rousmaniere & Barb Evans
United Kingdom	Senior Junior Womens	Tim & Kay Tavinor Phillip Marshall & Anne Gregory Sue Antonelli & Sarah Mees
Uruguay	Senior Junior	Ricardo Fabini & Ignacio Saralegui Pablo Defazio & Diego Stefani

Other International Trophies

Nordic Championship	Thomas Iversen & Schmidt
Bacardi Series	George Szabo & Jeff Baker
Gamblin Series	Shinichi Uchida & Lori Lowe
Zimmerman Trophy	George Szabo/C. Newman/J. Baker
Wiibroe Cup	Thomas Iversen & Nicolas Hansen
Bermuda Int'l Race Week	Lee Griffith & Lisa Griffith
Open Belgian Championship	Preben Kristensen & Offe Schmidt

European Regatta Calendar

April 1-2 Copa de España, Spain
 April 1-2-3 Sanremo, Easter Regatta, Italy
 April 1-4 Trofeo Princesa Sofia, Majorca, Spain
 April 10-11 Brouwershaven, Holland
 April 17-18 Orta, Italy
 April 17-18 Gran Trofeo, Valencia, Spain
 April 24-25 Trieste, Italy
 April 24-25 Horsens, Italy
 April 24-25 Bracciano, Italy

 May 1-2 Le Havre, France
 May 1-2 Monfalcone, Italy
 May 1-2 Majsnipen, Sweden
 May 8-9 Cazaux, France
 May 8-9 Var, Berum, Norway
 May 8-9 Blue Circle, UK
 May 8-9 GUL - Malmo, Sweden
 May 15-16 Cerro, Italy
 May 15-16 Club Nautico, Madrid, Spain
 May 15-16 Trofeo Bahia de Vigo, Spain
 May 21-24 Wibro Cup, Espergaerde, Denmark
 May 21-24 Tampere, Finland
 May 22-24 Lorient, France
 May 29-30 Spring Cup, Asgarstrand, Norway
 May 29-30 Trofeo Diller's, Madrid, Spain

 June 5-6 Le Havre, France
 June 5-6 les Mureaux, France
 June 5-6 Erth Town, UK
 June 12-13 Créteil, France
 June 12-13 Red & Green Cup, Vestfjordens, Norway
 June 12-13 Brenzone, Italy
 June 12-13 Maldon, UK
 June 12-13 Horsens, Denmark
 June 19-20 Talamone, Italy
 June 19-20 Helsinki, Finland
 June 19-20 Caldonazzo, Italy
 June 24-27 Norwegian Nationals
 June 26-27 Créteil, France
 June 26-27 Belgirate, Italy
 June 26-27 Oostershelde, Holland
 June 26-27 Stone, UK
 June 26-28 Trofeo Inauguración, Santiago de la Ribera, Spain

 July 1-4 Danish National Championship
 July 3-4 Luino, Italy
 July 3-4 Broadstairs, UK
 July 9-11 Hagon Regatta, Hanko, Finland
 July 10-11 Italian Masters/Women, Brenzone, Italy
 July 10-11 Wilsonian, UK
 July 10-13 French Open, Lorient, France
 July 15-17 Audierne, France
 July 17-18 Talamone, Italy
 July 17-18 Bellano, Italy
 July 17-18 Ledro, Italy
 July 19-21 Vetternsnipen, Motala, Sweden
 July 22-24 Nordic Championship, Motala, Sweden
 July 26-27 Abersoch, UK
 July 30-Aug 1 French Open, Martigne, France
 July 30-Aug 1 Torri del Benaco, Italy

 August 4-8 North European Open, Harwich, UK
 August 7-8 Claovey, France
 August 7-8 Brouwershaven, Holland
 August 9-10 Claovey, France
 August 17-19 KNS, Norway
 August 21 Open Junior/Ladies, UK
 August 17-21 Junior World, Almeria, Spain
 August 19-22 Finnish Nationals, Kokkola, Finland
 August 21-22 Vestfjordens, Norway
 August 21-22 Lorient, France
 August 21-24 Italian Championship, Rosignano, Italy
 August 28-29 Open Belgian, Brouwershaven, Holland
 August 29-30 Burnham, UK

September 4-5 Lorient, France
 September 4-5 Créteil, France
 September 4-5 Asker, Norway
 September 4-5 Chioggia, Italy
 September 4-5 Pori, Finland
 September 4-11 World Championship, Spain
 September 11-12 Créteil, France
 September 12-13 Masters, Spain
 September 18-19 Créteil, France
 September 18-19 Asgarstrand
 September 18-19 Muggia, Italy
 September 18-19 Budworth, UK
 September 25-26 Cartagena, Spain
 September 25-26 Porto Odesclachi, Italy
 September 25-26 UK

 October 2-3 Berum, Norway
 October 2-3 Chall Le Bour, Belgium
 October 3-4 Castro Vidiales, Spain
 October 8-12 Spanish Nationals, Spain
 October 14-15 Villagarcia, Spain
 October 21-22 Skanderbor, Denmark
 October 23-24 Claovey, Spain
 October 30-31 Ciudadela, Spain
 October 30-Nov 1 Cazaux, France

 December 5-7 Santiago de la Ribera, Spain
 December 5-8 Alicante, Spain

SCIRA National Championships

Argentina	August 14-17	Santiago del Estero
Belgium	August 28-29	Brouwershaven, Holland
Brazil	January 24-30	Rio de Janeiro
Denmark	July 1-4	
France	July 10-13	Lorient
Italy	August 21-24	Rosignano
Norway	June 24-27	Bergen
Spain	October 8-12	
United States	July 24-30	Mission Bay, CA
United Kingdom	August 5-8	Harwich

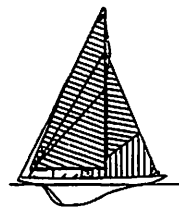

SINGLEMAN'S MODEL BOAT WORKS

ONE DESIGN CLASS HALF HULL
 TROPHIES & AWARDS
 VISIT OUR WEB SITE FOR COLOR PHOTOS,
 PRINTABLE BROCHURE & COMPLETE
 ORDERING INFORMATION.

[HTTP://WWW.AWARDS4SAILING.COM](http://www.awards4sailing.com)
 PHONE/FAX: 518-355-2119

Sailing The Christmas Cracker

I had reason to be in England during most of December 1998 and new I would miss one of our mid-winter regattas on the Richmond Riviera, so I wondered if I could get a ride sailing Snipes in England. I had noticed the English winter regatta reports on the Snipe mail server, so I fired off an email to Richard Lambert the author of the reports and asked if there was any chance they could accommodate me. Richard promptly replied that indeed they could, their Christmas Cracker regatta was December 20th and they were expecting about twelve snipes. I was amazed at how simple this was. Richard and I traded emails a number of times as my departure to England approached and Richard had indeed confirmed a snipe for me. I couldn't believe my good fortune and to top it all off the Snipe was actually a brand new Devoti and I could be the first American to sail one. I was duly impressed.

I stayed in contact with Richard after I arrived in England and got directions to Richards house with instructions to be there by 8:45 am. Everyone I met in England carried a road map of the whole country, as the road system has evolved over centuries and is not exactly intuitive. The route to Richards was not made any easier by the roadwork and detours, but I got there on time. It turns out Richard and his wife Nicky were at the Worlds in San Diego having qualified for the English team. They said what a great time they had in San Diego, and what a great job everyone had done to make them feel welcome. After they loaded their car with all manner of foodstuffs we were off to the regatta. The Blue Circle Sailing Club is located in an industrial area of Kent next to the Thames estuary, very much like our venue at Lake Washington in Sacramento. Richard and Nicky it turns out were one of the main organizers of this event and we arrived first to unload all the food they had prepared for the regatta. For the first time after my arrival in England the sky was blue the sun was out and it was not raining, yeah, but it was cold, the temp must have been hovering around 38 degrees, brrrr. As we waited for the other competitors to show up I helped Richard uncover some of the Snipes kept at the club.

My ride arrived along with Ian, Richard, Phillip and Mr. and Mrs. Marshall. The Marshall's own two Snipes, Ian and Richard usually sail their new Devoti and Phillip and his junior crew sail their Skipper Snipe. I was going to be paired with Richard Marshall in the new Devoti and Ian and Phillip were going to sail their Skipper snipe. We quickly got the boats rigged and we bent on the sails I had brought from the States. I thought it would be cool to have a USA sail number on the lake.

The skippers meeting described the course as sort of "T" shaped with all marks left to port. There were snags down the center of the lake marked with poles with just two gates to pass from one side of the lake to the other. There was a windward leeward leg in the main body of the lake with a reaching leg through the gates to the other side of the lake and back. In all there were about five marks to negotiate to make a lap. We wrote the marks down and taped the sequence into the boat where Richard and I could both see it. I had so many layers of clothes on I felt like a penguin, with about the same dexterity and mobility. We hopped in the boat and took off for the start area. After we had convinced ourselves we could go upwind and downwind in the 12 knots of breeze, I made a mental note of the new names for various items in the boat i.e. centreplate for daggerboard and kicker for the vang.

We had what was for me a great start about a third of the way down the line from the favored committee boat end, going fast with clear air to weather. There had been plenty of heated conversations at the start we had managed to avoid. Richard took over the tactical chores while I settled down in the unfamiliar Devoti and concentrated on driving the boat as fast as I

could. We rounded the top mark in fourth place right behind Richard and Nicky Lambert. Our first few mark roundings were a little sketchy, nearly capsizing rounding the bottom mark when the mainsheet cleated. Thankfully Richard kept the boat right side up and I made a concerted effort to keep the mainsheet out of the cam cleat. After the first lap was complete I confirmed with Richard we were finishing, he said no we have four more laps to go. What! you have to be kidding was my response. Four more laps I repeated incredulously. Oh my god this was going to be a long day. The fleet gradually divided up into a distinct "A" and "B" fleet with Richard and I bringing up the tail end of the "A" fleet with a growing gap to the "B" fleet. Mercifully the Race committee shortened the race to three laps and Richard and I finished a respectable fourth in the Snipe fleet.

What followed would turn into a pattern repeated after every race. We would all sail back to the dock, furl the sails, march into the club house and have a hot cup of tea, very civilized and very British. Considering how cold it was I was not complaining, the hot tea warmed me up. Mr. and Mrs. Marshall were encouraging, they told us our tacking improved as the race wore on, they had been observing our efforts from the cozy confines of their warm car parked next to the lake.

After another race committee briefing where they explained the new course, shortened by one mark and a couple marks left to starboard, we left the dock for race two. The wind had picked up to about 14-15 knots so we made a few upwind sail adjustments. We were in good shape about a quarter of the way down the line with twenty seconds to go when we found ourselves being hailed to come up by a boat fast approaching from leeward and clear astern. We accelerated and bore off into a gap to leeward then came back up onto the wind as the gun went off and we had another good start. It was chaos at the top mark, we approached on the starboard tack layline ready to round to port then realized we needed to round to starboard, oops! We dodged the first two boats that rounded and bore off in front of us, starboard we cried, as we bore off to make the mark with the rest of the fleet on port scrambling to give us room. I think we rounded in third or maybe fourth, but we were subsequently rolled by boats in the passing lane on the way to the bottom mark. We were now planing on the reaching legs, I was amazed at how quickly the Devoti planed, certainly not in my McLaughlin back home with similar wind strength and crew weight. We had a terrific race with another Snipe for fifth place, we would position on what seemed like every leg. The racing was much closer in this race with no discernable separation into an "A" or "B" fleet. Richard was terrific he always managed to keep us in clear air and out of trouble upwind. Praise the Lord the race committee had again shortened the race after three laps and we were coming into the last bottom mark right on the tail of our opponent. We had a great rounding and were going fast on the beat to the finish. We traded tacks with our opponent and gradually we got ahead and managed to hold them off to take fifth in the Snipe fleet. The Devoti was impressive upwind too.

Back to the docks and the club house for more hot tea and the hearty lunch prepared by Richard and Nicky. We had jacket potatoes slathered with your choice of cheese, beans or chili, yum. It was way too much for me I was only able to demolish about half of my more than generous portion.

The third and final race of the day turned out to be a bust and we took it as our throw out. After fouling out not once but twice in basic port starboard infractions it was obvious I was getting tired. The blue skies were suddenly replaced by menacing black clouds and the wind suddenly picked up to a solid 20 knots and I was not

having any fun. The reaches were now very exciting but the spray coming off the bow was like someone throwing buckets of ice water in your face, capsizing was NOT an option. With my aversion to the mainsheet cam cleat I was having trouble holding onto the mainsheet with only one ratchet block taking the load, I told Richard I had reached my threshold. I know Richard could easily have carried on, but he gamely called it a day too and we headed for the dock and a jump on getting the boat out of the water and packed away. Putting the boat away on its very trick dolly-trailer combination was a snap. The trailer itself never has to be put in the water to launch or retrieve the Snipe, you simply roll the dolly on and off the trailer. The Snipe lives on the dolly which is locked into the trailer for towing, very slick item.

After a hot shower we all retired to tell our war stories in the club house with of course more hot tea. The hospitality of the Blue Circle Sailing Club was second to none, they repeatedly refused to let me pay for anything like registration, any of the numerous cups of tea or lunch. Ian and Richard Marshall refused to accept any fee for chartering their new Devoti, just think of it as a Christmas present, they said. Thanks guys I had a terrific time sailing with you all, it was fun and I would like to extend an invitation to any of you and the Snipe community in general to sail with us in San Francisco if you ever find yourselves in the neighborhood.

—Joe Harvard #26615
Snipe Fleet 12

Your #1 Bird House!

- *Go-Fast Main & Jib Sheets!
- *Pole Launcher Kits
- *Custom Jib cars & plates
featuring **RONSTAN'S**
Compact SMART RATCHET
for 5/16" line. *Small & Light!*



- *Sea Sure gudgeons & pintles
- *Aigle & Douglas Gill boots
- *Henri Lloyd & Gill dinghy
sailing suits
- *Full Service Rigging Shop
- *Snipe Experienced Staff!

Sailing Supply

2822 Canon St

San Diego, Ca. 92106

1-800-532-3831

SAILING_SUPPLY@msn.com

*We'll Ship Anywhere in the
U.S.A., Next Day Service.*

XXX Comodoro Rasco Regatta

Miami, Florida

Peter Commette sailing Saturday with Brian Kamilar and Sunday with daughter Sheehan won the XXX ANNUAL COMODORO RASCO REGATTA. Ernesto Rodriguez with crew Naomy Basto were the runner up. Kay Voss and Jane Snedaker won the AICARDI FLEET with Bergie and Beto Montarroyos in second place. We had two boats from out of town, Matt and Laura Bryant that took THIRD overall and Jim Richter with crew Cindy Weatherby.

We sailed 3 races on Saturday with Easterly Winds 10 to 15 and 2 races on Sunday with Southeasterly Winds 10 to 12. What can I say? Biscayne Bay at its best!! The Weather had been specially ordered for this Regatta!

The Race Committee did an excellent job with Windward Leeward Courses and moving the weather mark with every windshift. We thank Race Committee Chairman Jack King and the dedicated Club Members and friends that helped, among them Garie Blackwell, Jeanne Buntun, Marge Sherman, Davis Tompkins, Will Bourne, Jr., Sharon Terenzio, Vicky Rosenbloom, Heather Wulkan and Bruce Schneider.

All, including members of the Race Committee, enjoyed Saturday night LASAGNA dinner by Carmen Diaz. Thanks for coming!

Our Coconut Grove Sailing Club Commodore Bill Beavers presented trophies for the first and second skippers and crews both for



the Rasco and the Aircardi (Blue Fleet). After trophy presentation, the traditional LA BOMBA took place with the winners drinking from LA BOMBA while the sailors sang LA BOMBA VA, LA BOMBA VA!! And they drank it all!!

Photo above: Standing from left to right: Jane Snedaker, CGSC Commodore Bill Beavers, Kay Voss, CGSC Vice Commodore Stuart Sorg, Peter & Sheehan Commete, Race Committee chairman Jack King. Front, left to right; Beto Montarroyos & children, Bergie Montarroyos and Naomy Bastos.

—Gonzalo Diaz, Sr.
Miami Fleet 007

CGSC, Coconut Grove, Florida, Feb 6 - 7

Pos	Sail#	Helmsman	Crew	Club	Race 1	Race 2	Race 3	Race 4	Race 5	TotPts	Position
1	29114	Peter Commette	Sheehan Commette	LYC	2	2	0.75	2	0.75	7.50	1
2	27363	Ernesto Rodriguez	Naomy Basto	Miami 7	3	4	3	0.75	2	12.75	2
3	29373	Matt Bryant	Laura Bryant	SPYC	4	3	6	6	3	22.00	3
4	24776	Kevin Downey	Cristi Stroud	CGSC	7	8	2	3	6	26.00	4
5	28812	Gonzo Diaz	Pavel Naranjo	CGSC	5	6	7	7	5	30.00	5
6	28814	Gonzalo Diaz, Sr	Chris Armstrong	CGSC	8	5	9	5	4	31.00	6
7	28810	Augie Diaz	Andrew Blom	CGSC	0.75	0.75	4	18DNC	18DNC	41.50	7
8	28672	James "Jim" Richter	Cindy Weatherby	SPYC	10	7	5	8	13DNF	43.00	8
9	27364	Carr Moody	Rick Jarchow	LYC	6	17DNF	18DNC	4	7	52.00	9
10	26900	Kay Voss	Jane Snedaker	CGSC B	12	12	14	9	8	55.00	10
11	24995	Bergie Montarroyos	Beto Montarroyos	CGSC B	11	9	10	12	15OCS	57.00	11
12	22851	Pam Kelly	Michael VandeKreeke	CRYC	9	11	8	14DNF	18DNC	60.00	12
13	25058	Robin Baker	Janet Plitt	PBSC B	13	14	11	16OCS	9	63.00	13
14	28791	Jim Janda	Connie Moore	Miami 7	14	13	15	11	11	64.00	14
15	28694	Linda Wennerstrom		KBYC	15	10	13	18DNC	18DNC	74.00	15
16	25374	John Uchino		Miami 7 B	18DNC	18DNC	18DNC	10	10	74.00	16
17	23391	Fernando DeCardenas	Carlos DeCardenas	CGSC B	17	16	12	18DNC	18DNC	81.00	17
18	26486	Jay/AJ Chen/Suarez	AJ/Jay Suarez/Chen	CRYC B	16	15	16	18DNC	18DNC	83.00	18

1999 DEAD OF WINTER REGATTA

And Crewless in St. Pete

The first Snipe event of the New Year was graced with good breezes, hopefully a positive omen for the coming year for all Snipe regattas! The festivities began with the annual fireworks party aboard the Welch's boat on New Year's Eve. The evening was cool, keeping the partiers, headcount about 50, inside watching sailing videos, catching up with each other and merry making in general. But at midnight, we all crowded onto the upper and aft decks to watch the fireworks display provided by the City of St. Pete, just for us! Most of the revelers were gone by one a.m., some in anticipation of the Third Annual Competition for The Captain Bligh Admiration Cup, the single handed Snipe regatta aptly named "Crewless in St. Pete".

New Year's day dawned with light breeze, make that very light breeze, which is just perfect for single-handing your Snipe. There is quite a bit to do in a Snipe on short courses, when you have to manage it all alone. It does get busy! Twelve Capt. Blighs made it out to the course to start the race. Several others elected to use the day to practice for the real thing, and many others arrived just in time for the noon skipper's meeting (this is not the sort of regatta you rush into at early hours) but not in time to get rigged and splashed for the races. The dirty dozen who lined up for the first start included seven locals, one Canadian competitor, two Japanese competitors, one Viking, and one more Lone Ranger from out of town, Captain Bligh JibeTech. Last year's Champion, local Captain Klotz, took race one, sporting ten year old sails that appeared brown compared with the other solo sailor's gleaming whites. Captain Uchida, the 1997 Champ, made it across eighth, still getting to know his charter boat. However, Captain Pimental, quite familiar with his vessel, finished second, with his crew for DOW standing by in the photo boat complimenting his well executed roundings and tactical decisions. Local Captain Welch finished third, followed by The Viking. Race two was captured handily by Capt. Pimental, with Capt. Klotz taking a second, and Capt. Uchida finishing third, followed by a very determined Viking. Race three saw a change of characters. Capt. Pimental, perhaps wanting to give his crew a taste of the single handed experience, or perhaps just wanting to catch his breath, invited Capt. Carol Newman Cronin to take his vessel for the third race. She swapped places with him without hesitation, and went on to have a dandy pin end start, and to win the race quite handily. The Viking, beginning to get used to this crewless stuff, took second, and Captain Sawada, just beginning to get the hang of his chartered boat, grabbed third. Capt. Klotz slipped across the line in fourth. The last race saw the original cast back at the helm, fully rested, after a ride in the photo boat. Captain Sawada, now fully familiar with his chartered craft, took the number one position at the finish, The Viking snagged another second, with Capt. Klotz of the brown sails finishing third. Captain Pimental collected a fourth place after his rest in the Whaler, which was good enough to win him the High Honor of the 1999 Captain Bligh Admiration Cup, which he will gladly share with Co-Captain, Carol Cronin! Trophies were awarded later in the day at the famous New Year's Day party, hosted by Matt and Laura Bryant.

Saturday, Jan. 2, 1999, began as a perfect day for sailing on Tampa Bay and stayed that way. In spite of a general recall to start off the day, three good races were completed, with the breeze building slightly throughout the day, giving the photos boat some nice photo opportunities on the reaches. The Pimental/Cronin team started off hot with two firsts. The Norwegian team of Birger Jansen and Liv Ulveie looked very strong with two seconds, as did the Canadian entry of Kneulman/

Brown, with two third places. The Japanese team of Uchida/Oka showed promise with two fourths. The last race of the day went to Birger Jansen, with Andy and Carol taking a fifth, Dirk Kneulman nailing second, and Shinichi Uchida earning third; at the end of the first day of racing the standings were Jansen, Pimental, Kneulman, and Uchida, with the Plines and the Bixbys tied for fifth position. Spirits were good after a great day of racing, and the fleet retired to the St. Petersburg Yacht Club for cocktails and dinner.

Day two of racing began rather slowly with light air, and a postponement to give the competitors time to get to the starting area in the light conditions. The breeze picked up as the last of the boats to make it out to the course, and two more races were completed in good time and with good wind. The trophy places didn't change in

spite of two more races, and the tie between the Plines and Bixbys was settled in the Bixby's favor. Boats were packed up, trophies were awarded, and good-byes were exchanged until next time, which for many of us will be the Midwinter Circuit. Hope to see you all there!

Now is the time to make your plans for DOW 2000!!! Come to St. Pete and sail the first Snipe regatta of the century, of the millennia! Watch the Snipe Class Web site and the Bulletin for details. We plan to make this a big one, and hope that YOU will join us! Come early for a little Florida sunshine (with any luck) and to participate in a one-of-a-kind Snipe event, "Crewless in St. Pete"! Some great parties are now in the planning stages. There will be a hefty discount for early registration, and local housing will be at a premium, so register early!

—Bill & Sherry Welch
Fleet 801



photo above: Winning "crewless" skipper, Andrew Pimental, makes a perfect tack - singlehanded. Sherry Welch photo.



**Our Covers Are Expensive
...so they can cost less!**

Sure our covers may cost more, but they last longer! So your cost per year of use is actually less than cheap imitations.

3 in 1 Cover		
Polyester Army Duck	\$270 ppd
Acrylic - White	\$266 ppd
Acrylic - Colors	\$281 ppd
(Also available in Skirted Style.)		
Bottom Cover	\$259 ppd
Flannel lined waterproof grey canvas with drain hole.		
Football Cockpit Bag	\$18 ppd
Hangs in cockpit and zips closed.		
Daggerboard Cover	\$46 ppd
Flannel lined canvas.		
Specify size and shape.		
Rudder Cover		
Flannel lined canvas	\$37 ppd
Nylon shell, foam lined	\$51 ppd

- Fabrics finished to our specifications
- Strongest possible flat-felled (Levi) seams
- More reinforcements than other brands
- 5/16" shock cord in hem & tie down points
- Designed for competitive sailors by multi-class National Champion Bob Rowland
- Manufacturing & stocking Snipe covers since 1972

INVEST IN THE BEST... Covers by The Sailors' Tailor

Send check or Money order to :

The Sailors' Tailor

191-SN Bellecrest, Bellbrook, OH 45305

Visa/MC orders call Sandy Rowland: (937) 862-7781
OR see Bob, Sandy or Scott in Snipes 26746 & 26303

Lillia Snipe

Working together with the world's best sailors, we thought, designed and built...

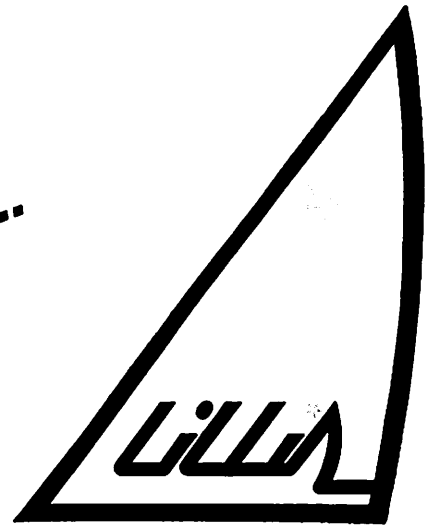

New Lillia Snipe

Computer designed hull for the best all-around performance.

Deck modified with the most comfortable hiking position.

Deck hardware lay-out thought for more simplicity and access.

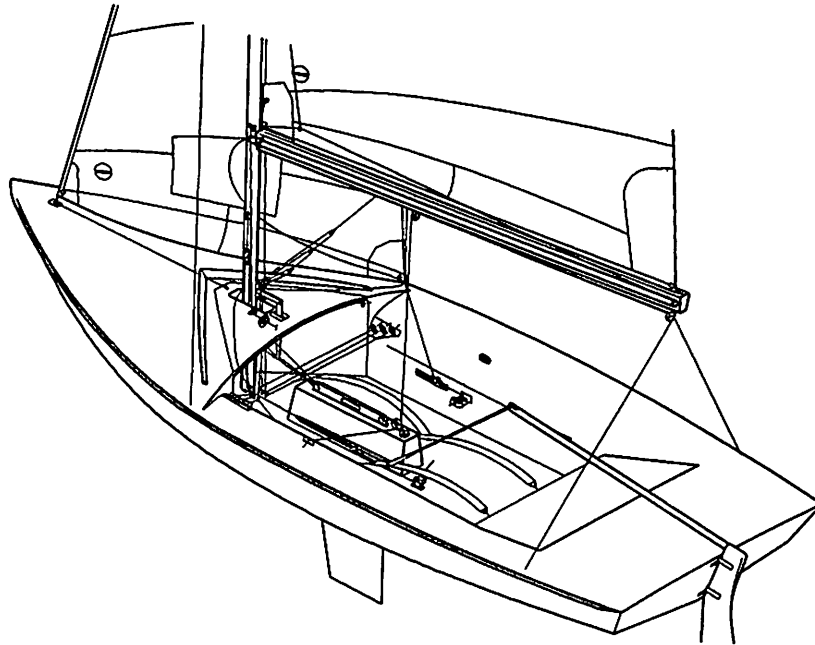

Always ready to sail, always ready to start.

LILLIA BOATYARD - 22010 Musso - Como - Italy - Phone 0039-344-81223 Fax 0039-344-81568

LILLIA SOUTH AMERICA

Niteròy - RJ

Phone - Fax 0055-21-616-2550

LILLIA NORTH AMERICA

190 Hagman Rd. - Winthrop, MA 02152

d- 617-539-0992 e-617-846-1772

Fax 617-539-0614

Halloween Regattas Were Scary For Our Competition.

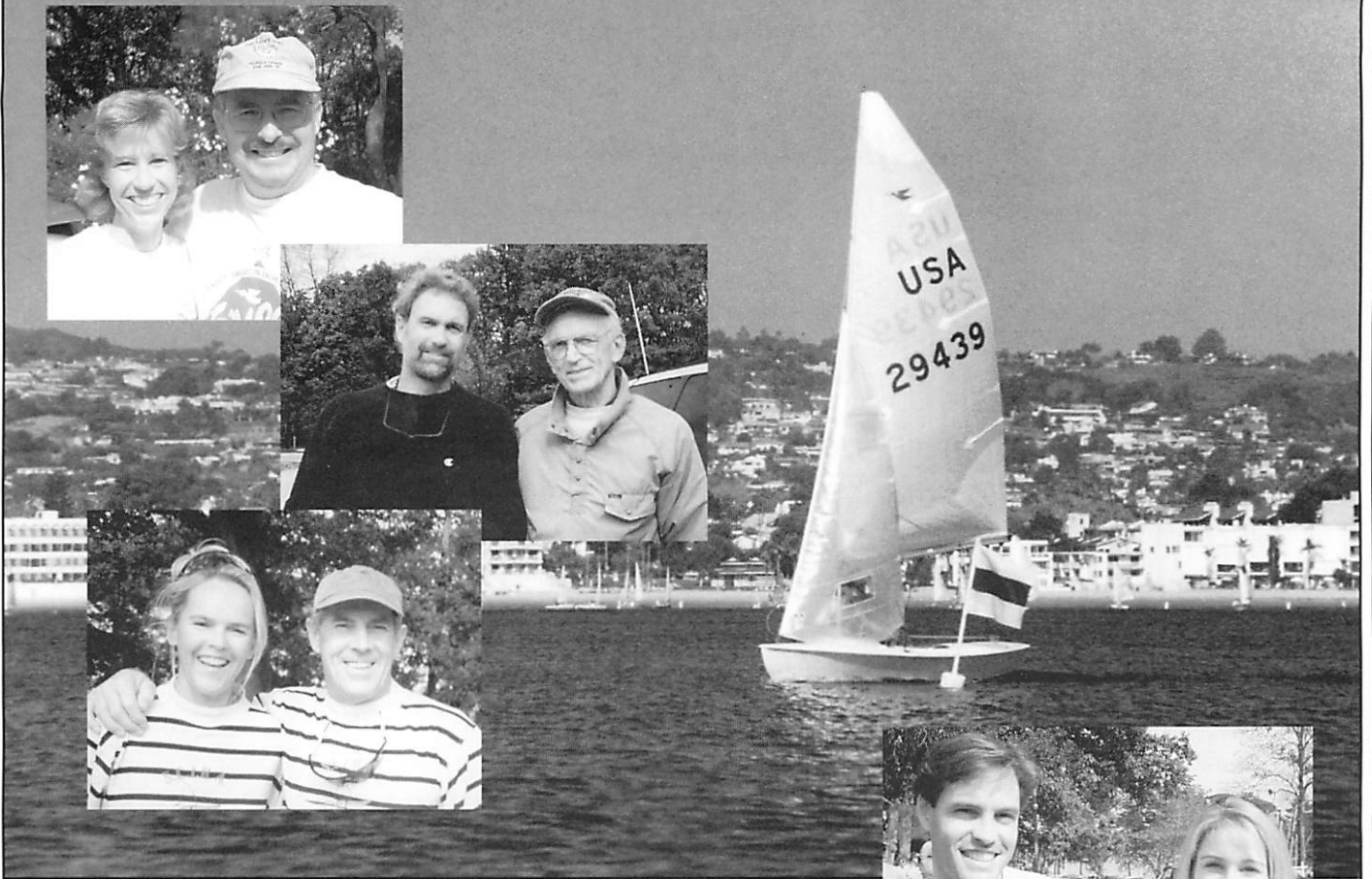

These faces may not look very threatening, but when they took to the race courses on Halloween with North Sails on their teams, the competition took cover and was nowhere to be seen!

Large photo: Gene and Tami Ratliff round the mark en route to winning the 1998 Carolyn Nute Regatta at Mission Bay, CA

Insets (top to bottom):

Scotty and Cindy Cline - 2nd at the Atlanta Halloween Regatta

George and Greg Fisher - U. S. Masters National Champions in Atlanta

Birger Jansen and Liv Ulueie - 1st U. S. Masters Nationals in Atlanta

John, Leslie (and Maxwell) Irvine - 1st Atlanta Halloween Regatta.

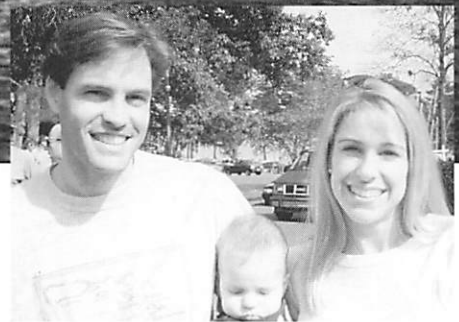

www.northsailsod.com



No. 1 in One Design

North Sails One-Design West Chris Snow, Vince Brun 1111 Anchorage Lane • San Diego, CA 92106

PH: (619) 226-1415 FX: (619) 224-7018 chris@od.northsails.com

North Sails One-Design Central Greg Fisher 484 E. Johnstown Rd • Gahanna, OH 43230

PH: (614) 418-9410 FX: (614) 418-9411 greg@od.northsails.com

On the Circuit Representatives: East Coast Henry Filter (410) 643-1486; Northern California Bart Hackworth (510) 522-5373;

Southern California Doug Hart (619) 421-2745