



August/September 1999



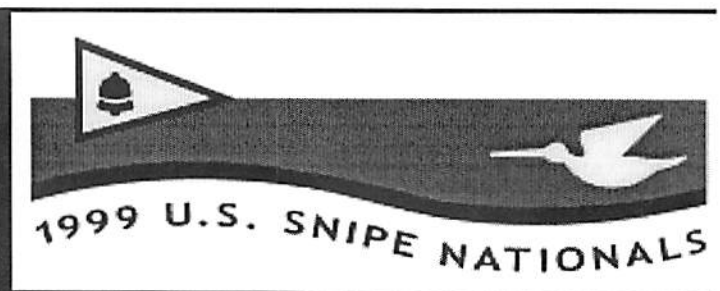

Photo collage from US Nationals:
 Top: Proud Dad Keith Dodson shares the Wells Trophy with crew/daughters Kaley and Corey. Doug DeSouza and Jerry Thompson look on.
 Right: US Junior National Champs Lauren Maxam and Brian Haines.
 Below: In contrast to the Bulletin cover and ocean venue, the Bay offered it's challenges; fleets of kayaks and pleasure craft!



Around the Snipe World

ADDRESS CHANGE
 Birger Jansen
 Norwegian National Secretary
 Fürstlia 27A
 1367 Snarøya, Norway
 phone & fax: +67-11-07-11
 mobile: +97-48-44-80

SEITECH Launching Dolly

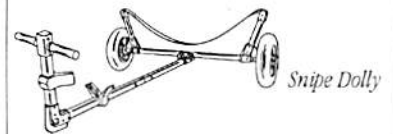

Ideal for launching, moving, and storing your boat. Light, strong, corrosion-proof, maintenance-free. Aluminum frame, engineered plastic joint components, stainless steel fasteners, 3"-wide sling, and pneumatic ATV wheels with plastic rim & Delrin needle bearings. Rolls easily over sandy and rocky beaches.

Comes as a kit. Easy to assemble, no-tool breakdown into 3 pieces. UPS shippable. One year warranty.



We've got a dolly for any dinghy!

SEITECH Marine Products, Inc.
 PO Box 514, Portsmouth, RI 02871 USA
 Tel: 401-683-6898, Fax: -6897
 E-Mail: Sei52@aol.com Web: www.seitech.com

US Women's Nationals

The Champion's Viewpoint

Last year, my arm had to be almost twisted off to attend Women's Nationals. After several lackluster all women's regatta experiences in college and beyond, I just couldn't believe it would be much fun. Fortunately, several people twisted hard enough to get me there so I could find out how wrong I was, and this year, I couldn't wait to send in my entry form.

If you measure success in quantity, the 1999 Women's Nationals would have to be called almost twice as successful as last year's. 22 boats made the starting line, a big jump from the 12 boats that attended the first two events in '97 and '98. Most of the credit for this incredible growth goes to the local Mission Bay Snipe women—especially spark plug Carolyn Brown, who located boats, persuaded skippers to steer and crews to point them in the right direction, and even made last minute airport pickups for stressed out competitors.

If you measure success in quality, however, the increase over last year would be even more noticeable. From a floundering flock of Snipes trying to stay out of each other's way, we have developed into real acers, vying for a spot on the line and trading tacks to line up for the next puff. This growth in ability can also be traced back to the local fleet's efforts; after two women's regatta/clinics this spring, a large portion of the fleet was tuned up to an almost audible pitch. Perhaps as a result, there were a few raised voices, a few "Protest" calls heard. But discussions afterward were animated and honest, equally supportive of those still on the steep side of the learning curve and those who had risen to the top more quickly than expected.

Mission Bay also turns out to be an ideal spot to race with a light team; you actually get to hike hard in the big 10 knot puffs. And skippers, significant others, and other interested parties could second guess every tack and gybe from the yacht club porch, margaritas in hand, since the weather mark was usually only a few boatlengths away.

My 1998 teammate Jerelyn Biehl decided to steer herself this time around, so I took full advantage of Lisa Pline's pregnancy and borrowed her crew, Sherry Eldridge. Skippering against a former teammate added a special dimension to the experience. Side by side on a run on Sunday, Jerelyn called over, "Hey, share that puff!" as Sherry and I began to slide by to leeward. "I would," I responded. "But you hogged the last one." Jerelyn and her sister DeAnn won the first

Comments from Junior/Senior sailors at the Nationals

"I thought that the Snipe Jr/Sr Nationals was a great regatta. I had never really sailed a Snipe before, but I really enjoyed it. I liked skippering, and thought it was a great experience."

Melanie Roberts, 14

"I liked it, I had fun with Rick Merriman. I learned to feather in the puffs and other little things. I had fun sailing a Snipe. My Dad would have been yelling at me so Rick was calm and a good crew. I asked Rick what he thought (about tactics) then I added my thoughts and came up with my solution. I want to keep doing the Jr/Sr until I'm ready for the Jr/Jr."

Tyler Sinks, 10

"I had a great time sailing with Tyler Sinks in the Jr/Sr nationals and I think that the other crews had just as good a time with their skippers. It is a great way to get the juniors out in a Snipe when they are not quite ready for a Jr/Jr regatta. I would encourage everyone to give it a try and help build the future of the Snipe Class."

Rick Merriman, crew

"Warm water, light breeze - it was summer sailing at its best. Switching roles was a lesson in patience (for both of us) and an opportunity for father-son bonding. Thanks for a great regatta!"

Charles Heimler, crew

"Everyone there was really good and it was hard but fun to sail because the courses taxed your ability. I liked the pizza!"

Graham Heimler, 13

"The Jr/Sr Nationals are a great idea. It gives the younger kids a chance to learn a lot about the boat and experience the fun of skippering at the Snipe Nationals. It's fun for all! I hadn't crewed in a Snipe in about 30 years!"

Mark Reynolds, crew

"This race gave many kids that would normally be crews the chance to drive. It's a great opportunity to learn a whole lot about Snipes and about sailing in general. It's kinda odd seeing some of the best sailors in the world at the mercy of 11 year old Cameron. It's like taking your hero out sailing."

Connor Herron, 14

"Since Scott, Sean and I have only been in Snipes since October, we were somewhat inexperienced. We realized when we started to sail with the group it was designed for younger skippers, but we had fun anyway! Most likely Scott will do Jr/Jr next year as he gains more experience and confidence with a crew."

Steve and Scott Adams

"I was a little intimidated having Doug Hart crew for me, but after the first race, I realized we were a team sailing together and he wasn't analyzing my every move. It was awesome sailing with such a great sailor!"

Piet Van Os, 16

"After winning this coveted event last year, Cameron and I realized that we would have stiffer competition this year. Preparation last year was easy - we only had to fill water-balloons. This year was more difficult - we expected to be attacked the first day with water balloons and squirt guns so we decided to work on our defensive strategy. The super soaker was key."

George Szabo, crew

Junior Nationals

	<i>Skipper/crew</i>	<i>Sail #</i>	<i>Fleet</i>	<i>Finishes</i>
1.	Brian Haines/Lauren Maxam	22815	Mission Bay	4-2-1-1-3
2.	Chris Wright/Ian Schneider	27569	Mission Bay	3-3-4-4-4
3.	Dustin Kays/Sean Adams	25071	Atlanta	5-5-3-3-5
4.	Matt Megla/Jonathan Boyd	27377	Mission Bay	cnf-6-dsq-2-1
5.	Brian Lake/Jennifer Warnock	28854	Mission Bay	2-cnf-ret-7-2
6.	Jonathan/Stefanie Carroll	25395	Mission Bay	6-10-2-5-12
7.	Tyler McKay/Karen Richards	29166	Mission Bay	7-4-9-8-11
8.	Brian Janney/Bud McKay	8686	Mission Bay	8-8-8-6-13
9.	Jarrel Price/Colin Johannessen	28468	Quassapaug	12-11-5-11-8
10.	Rachel Senturia/Darin Jarrasevich	29248	Mission Bay	9-9-7-cnf-10
11.	Clayton Dixon/Clay Burnup	29014	Atlanta	11-ret-10-12-9
12.	Lauren Bernsen/Tedd White	28333	Mission Bay	13-cnf-cnf-14-7
13.	Chris Clevenger/Stephen Swarth	23753	Alamitos Bay	cnf-13-11-15-14
14.	Matt Stine/J. Montgomery	29109	Mission Bay	dsq-7-dsq-p40-6
15.	John Bell/Michael Oliver	28107	Alamitos Bay	14-15-12-13-15
16.	Katy/Clay Towles	29808	Oklahoma City	15-14-13-16-16

Junior/Senior

1.	Piet VanOs/Doug Hart	29314	Mission Bay	2-1-1-1-1
2.	Tyler Sinks/Rick Merriman	28687	Mission Bay	1-3-2-2-3
3.	Cameron Biehl/G. Szabo/M. Reynolds	29672	Mission Bay	4-2-3-3-2
4.	Graham/Sean Biehl	29104	Mission Bay	3-5-4-4-6
5.	Melanie Roberts/Packy Davis	28215	Mission Bay	cnf-4-cnf-7-5
6.	Alex/Paul Levinson	26462	Indianapolis	6-7-8-9-7
7.	Scott/Steve Adams	25434	Atlanta	ret-6-cnf-6-8
8.	Joel/Cliff Wright	28108	Seattle	ret-8-7-8-9
9.	Connor Herron/Russell Oiring	28858	Mission Bay	dnc-dnc-dnc-5-4
10.	Graham/Charles Heimler	28447	San Francisco	7-9-9-10-10

Wells Series

1. Keith/Kaley Dodson	17235	Alamitos Bay	3-6-(14)-1-6-2	17.75
2. Jim Elms/Stacey Szabo	29537	Mission Bay	1-(15)-15-7-3-1	26.5
3. Pedro Lorson/Watt Duffy	28044	Sea Cliff	7-9-1-8-4-(22)	28.75
4. Steve Stewart/Michael Kelly	29108	Mission Bay	5-(18)-11-2-9-4	31
5. Brian Haines/Lauren Maxam	22815	Mission Bay	11-1-(16)-5-5-112	33.75
6. John Tagliamonte/Debbie Bennett	29311	San Francisco	2-5-6-14-(30)-7	34
7. John MacRea/Barbara Evans	26451	Winchester	(15)-7-10-4-8-8	37
8. Rick Arneson/Chris Wright	27569	Mission Bay	13-2-3-17-2-(19)	37
9. Sean/Jerelyn Biehl	29104	Mission Bay	8-4-2-(31)-10-14	38
10. Gonzo Diaz/Graham Biehl	28812	Miami	4-(44)-5-15-12-3	39
11. Gonzalo Diaz/Ana Fernandez	29914	Miami	18-10-(24)-10-1-6	44.75
12. George Walker/Theresa O'Dea	28369	Mission Bay	(29)-16-8-6-18-5	53
13. Kevin Dumain/Ros Corper	28409	Alamitos Bay	19-21-4-3-19-(37)	57
14. Gregg Morton/Janett Krefling	25080	Mission Bay	(34)-17-7-13-7-17	61
15. Paul Cronin/Michele Munroe	29592	Narragansett Bay	9-(29)-9-22-16-9	65
16. Tom Nute/Julie Mitchell	27522	Mission Bay	6-(22)-18-12-17-20	73
17. Dustin Kays/Sean Adams	25071	Atlanta	12-13-(22)-18-20-10	73
18. Don Hackbarth/Clayton Dixon	29014	Atlanta	20-8-19-(33)-11-16	74
19. Bob Bowden/Joanne O'Dea	28223	Mission Bay	(32)-14-12-16-24-18	84
20. Cliff Browning/Parker Shinn	29540	Indianapolis	(23)-19-20-11-22-21	93
21. Dave/Lorraine Schibler	29240	Mission Bay	(31)-3-27-24-14-26	94
22. Bertel/Nicolas Bojlesen	27668	Willamette	25-(35)-23-9-15-24	96
23. Russell Oiring/Connor Herron	28858	Mission Bay	14-27-13-20-(33)-32	106
24. Andrew Pontious/Robbie Gales	26843	San Francisco	17-24-26-27-13-(35)	107
25. Bob Coyle/Mary Buckley	24695	Medford	16-23-(35)-25-21-27	112
26. Greg/Kristin Mylett	29008	Cleveland	10-36-25-21-(42)-23	115
27. Joe Harvard/Katherine Neville	26615	San Francisco	(45)-11-31-29-25-25	121
28. Bob Jackman/Julia Lundquist	29250	Mission Bay	22-20-21-30-(37)-34	127
29. Nick Wilder/Megan Houseweart	29242	Mission Bay	27-21-28-(38)-23-31	130
30. Steve Keckler/Susie Decker	27238		30-(42)-29-19-29-30	137
31. Jonathan & Stefanie Carroll	25395	Mission Bay	26-32-32-35-(40)-13	138
32. Rob Pinkel/Sabrina Simpson	23965	Mission Bay	28-28-(37)-32-36-15	135
33. John/Maggie Manderson	28065	Barneget Bay	21-31-(33)-28-27-33	140
34. Vince Casalaina/Grace Fang	28856	San Francisco	38-37-36-34-(44)-11	156
35. Neil Bogue/Perri Lynch	25912	Seattle	36-33-(40)-26-26-36	157
36. Andy & Katy Towles	29808	Oklahoma City	39-(41)-17-37-28-41	162
37. Jarrel Price/Colin Johannessen	25413	Quassapaug	33-25-(41)-41-38-38	175
38. Jorge/Shelly Suarez	23753	Alamitos Bay	41-26-38-39-31-(51)	175
39. Dave/Barbara Carroll	28224	Mission Bay	42-38-(46)-23-46-29	178
40. Kent Sisk/Julie Muyco	27928	Mission Bay	46-30-30-(ocs)-35-47	188
41. Paul/Alex Levinson	26462	Indianapolis	cnf-34-34-36-(dnc)-dnc	195
42. Martin Bebb/Carole Veir	25517	Oklahoma City	37-(48)-45-42-32-42	198
43. Bob/Joseph Panza	25714	Quassapaug	53-49-(54)-44-34-28	208
44. Ava Moore/JVGilmour	25992	San Francisco	(49)-39-44-40-47-40	210
45. Cliff/Joel Wright	28108	Seattle	40-45-43-47-43-(49)	218
46. Gary Derrick/Clay Towles	23277	Oklahoma City	43-40-(50)-46-45-48	220
47. Todd Smith/Kathy Black	29316	Alamitos Bay	35-(dnc)-48-48-49-43	223
48. Shawn/Diane Zabriskie	26995	Seattle	(51)-47-39-50-48-46	230
49. Ralph Swanson/Marta Wallace	29999	Winchester	44-(53)-51-49-41-50	235
50. Jim Miller/Mindy Koblenzer	26832	Seattle	(52)-52-42-51-39-52	236
51. Steve/Scott Adams	25434	Atlanta	50-51-47-52-(53)-39	239
52. Charles/Elizabeth Heimler	28447	San Francisco	48-46-52-(53)-51-44	241
53. Jim/Tim MacKenzie	26460	Rocky Mountain	(ocs)-43-cnff-43-52-45	243
54. Fred/Ronnie Hegel	29535	Rocky Mountain	47-50-(53)-45-50-53	245
55. Jim Lampros/Dave Patterson	24106	Willamette	54-54-55-54-54-(dnc)	271

Women's - continued

escaping to the favored left side, which eventually gave us our second win of the day and secured our overall lead.

Two top ten finishes on Sunday sewed up first place for us, but second place was a tough battle right to the end with only 4.5 points separating second through fifth. Two local boats (Jerelyn Biehl/DeAnn Reynolds and Aine McLean/Lynn Sinks) started the regatta off well, but in the end the east coast teams (Pam Kelly/Michele Bustamante and Joni Palmer/Joyce Ferguson) crept back into second and third overall.

Organizers for next year's Oklahoma City Nationals were so excited by the '99 Women's Nationals that they have already arranged free housing for the participants in the 2000 event, so one less arm twist will be needed to increase fleet numbers once again. Come for the learning and stay for the fun... For those of us used to riding in the front of the boat and making the best of a skipper's mistakes, there is nothing quite so satisfying as stepping into the back--and making your own.

—Carol Newman Cronin



50th UK Snipe Nationals and 1st North Europeans

Twenty-six competitors entered the 50th anniversary UK Snipe Nationals which this year incorporated the 1st North European Open Snipe Championship. The event, which ran from 4-8 August, was hosted by Harwich Town Sailing Club and racing took place in Dovercourt Bay. Competitors from France, Italy and Spain joined the 23 British entrants.

The first race started cleanly in a slight breeze and former UK National Champions Matthew Smith and Matthew Baldwin got clear ahead at the windward mark. They demonstrated that despite a long absence from Snipe sailing, they had lost none of their tactical acumen as they covered to edge out Niccolo Belloni and Luigi Beducci of Italy at the finish. Chris Surrige and Peter Wolstenholme sailed confidently to claim third over the windward-leeward course.

In the second race, Olympic course 'O' was set and as the sea breeze filled in, Belloni and Beducci made no mistake to win despite a strong challenge from Maxim Romain and Stephan Mircich of France. Another former champion, Neil Martin, sailing with Giles Herrick, took third.

Saturday began and remained windless and despite several attempts to start a race, the competitors endured a six-hour wait before returning to shore, both races eventually being abandoned.

The race committee decided to add an extra race to Sunday's schedule and finally the wind blew in a range from 3 to force 5. A windward-leeward course was set for the fourth race and in the competitors' eagerness to start well, two general recalls were sounded. In the three attempts to provide a clean start,

the race committee, mindful of the tight schedule, quickly went through their collection of penalty flags. When the black flag was hoisted, common sense finally prevailed. Reigning champion Tim and Kay Tavinor used their vast experience at the highest level to make a perfect start. Once clear, they steadily increased their advantage and won ahead of Iain and Richard Marshall to post a Devoti Snipe 1-2. Belloni and Beducci's third underlined their metronomic consistency throughout the wind range.

The wind blew strongest for the fifth race which suited Alan Williams and Liz Crouch who revel in heavy weather. They led for a lap before eventually being overhauled by Martin and Herrick, whose victory put the six-time champion in a strong position overall. Tavinor took second and Belloni was third as Williams and Crouch slipped eventually to a well earned fourth.

The final race was won by Belloni and Beducci whose early lead was sufficient to enable the Milan-based pair to apply a loose cover over Tavinor. A strong finish by Mark and Sue Antonelli - despite an earlier capsize which kinked their mast - earned them a third which elevated them to overall sixth place. Belloni and Beducci took overall victory in the North European Championship and the Tavinors secured back-to-back UK Nationals titles by virtue of a better discard over Martin and Herrick.

The event was magnificently organised by Blue Circle SC Snipe Fleet Captain Liz Crouch whose energy and imagination ensured a memorable regatta for everyone who took part.

—Richard Lambert

Ladies and Junior Snipe Nationals at Blue Circle

A gentle breeze and pleasant sunshine greeted the 18 competitors who took part in the Snipe UK Ladies and UK Junior National Championships at Blue Circle SC on July 24. Race Officer Derrick Crouch set Olympic 'O' courses for each of the four races. The event was supported by Snipe builder Devoti Sailing Ltd who generously donated prizes for every competitor.

The ladies event was particularly close throughout. In the first race, Liz Crouch and Anne Gregory were adjudged over the line and this enabled Debbie Love and Diana Gregory to open up a lead which they held to the finish. Crouch took advantage of a poor start from Sue Antonelli and Jo Lloyd and held her off to take second.

Antonelli's performances steadily improved but in the second race she could do nothing about Love's upwind speed. She fended off Crouch's challenge to take second, and Janet Hoy and Dawn Stevens closed in to take fourth. The positions remained the same for the third race, but in the fourth, Antonelli finally got to grips with her borrowed boat to power to the gun. Love and Gregory's second was enough to secure their first Snipe Ladies Nationals title.

In the Junior event, new pairing Philip Marshall and Duncan Read warmed up nicely for their impending trip to Spain for the Junior Worlds next month with four straight wins. Nick Lett and Phil Shepherd got close in the third race but Marshall had too much upwind speed. Further back they were promising performances from Chris Rebbeck and Brandon Hawkes of Broadstairs SC, but they couldn't find a way past Alex Francis and Dean Munday in mid fleet. Graham Hoy and James Denniss showed plenty of promise in their first ever Junior Nationals and will be a force in years to come. Each helm received a brand new tiller extension and every competitor was presented with a sports drink bottle courtesy of Devoti Sailing Ltd.

—Richard Lambert

Overall North European Championship Results:

1st	ITA 29365	N Belloni & L Beducci	(Milan)	6.50
2nd	GBR 29611	T & K Tavinor	(Maldon YC)	11.75
3rd	GBR 27106	N Martin & G Herrick	(Budworth SC)	12.75
4th	GBR 29501	I & R Marshall	(Maldon YC)	19.00

Overall Ladies Results:

1st	GBR 27098	Debbie Love and Diana Gregory	(BudworthSC)	2.25
2nd	GBR 28384	Sue Antonelli and Jo Lloyd	(LittletonSC)	4.75
3rd	GBR 20557	Liz Crouch and Anne Gregory	(Blue CircleSC)	8.00
4th	GBR 29408	Janet Hoy and Dawn Stevens	(MaldonYC)	12.00

Overall Junior Results:

1st	GBR 29501	Phil Marshall and Duncan Read	(MaldonYC)	2.25
2nd	GBR 23980	Nick Lett and Phil Shepherd	(Blue CircleSC)	6.00
3rd	GBR 24705	Alex Francis and Dean Munday	(Blue CircleSC)	8.00
4th	GBR 27330	Chris Rebbeck and Brandon Hawkes	(BroadstairsSC)	12.00
5th	GBR 22471	Graham Hoy and James Denniss	(MaldonYC)	14.00

Ideas for Increasing Jib Longevity

Recent discussions on the internet Snipe list of jib cloth weight and durability have led several readers to give ideas of lengthening the life of a Snipe jib. Following are 2 excerpts for your reading pleasure.

I have always felt that the snipe jib has a tough life, and that we are often responsible for its failure. When we prepare to round the leeward mark, do we tighten the jib halyard without sufficiently easing the jib sheet? If the jib sheet is not eased, the foot of the jib is stretched and the material becomes fatigued. How about backing the jib while sailing before the start. If the leech gets caught on the pole while getting pulled around, fatigue occurs again. And enough can never be said about unnecessary luffing, whether it be at a dock or during a squall.

--Craig Leweck

The following are classic jib life shortening maneuvers, in approximate order of seriousness:

Capsize

Another reason to avoid flipping over: no jib should be expected to look the same after it has been dragged through the water and then flogged.

Flogging

Jib flogging is at times unavoidable (see item #1), but it can be seriously reduced. On the dock, put the jib up last/take it down first, and if you have to stay put for too long, double the middle of the luff back around the headstay. This will save not only your jib but your ears.

Approaching the starting line, crews should ease the jib only enough to luff the forward half of the sail. This depowers the sail without flogging the leech, since it is relatively stationary. And it also reduces the chances of the sheets twisting into a fantastic knot just in time for the starting gun.

3. Easing the main out into the jib leech

4. Backing the jib against the spreader

5. Backing the jib against the pole

These three items are less serious but more common, and all will quickly trash the leech (usually the first thing to go). And unlike the first two items, they are completely avoidable. Ask crews to ease the jib before easing the main, and always look up when backing the jib to avoid sharp turns.

Jib longevity is something we should work on, but like fleet building, most of it starts at a very local level.

—Carol Newman Cronin
Fleet 017, Narragansett Bay, RI

Ontario Open and Canadian Championships

Snipers from both the United States and Canada gathered in Oakville, Ontario, August 7-8 for the Ontario Open and Canadian Championships. On Saturday we had a light easterly with a building swell. The first race was won by Bill and Kristen Kelley. Then second was a runaway victory by John Mcallister and his son. Following the racing the competitors drank from the infamous Green Can, and enjoyed a wonderfully cooked meal. That evening, last years winners John Jackman and Steve Stewart decided to visit several of the towns local drinking establishments, and were not to be found when Sunday's racing began. It was their loss because from about 9:00 am onwards the wind gradually built from a light 2-5 knots to a fresh 15-18 knots. The race committee managed to squeeze in two races before the wind started hitting 30 knots. Ian Brown sailing with crew Monique Gaylor won both races to win the regatta, and regain his title of Canadian Champion.

Top finishers were as follows:

- 1) Ian Brown / Monique Gaylor
- 2) Lee Sackett / Grant Glass
- 3) Bill Kelley / Kristen Kelley

The Tradition Continues...

➤ Sails	1st 1997 Gamblin Series/Winter Circuit
➤ Covers	2nd 1997 U.S. National Championships
➤ Masts	3rd 1997 District 6 Championships
➤ Booms	1st U.S. Finisher (3rd Overall) 1996 Western Hemispheres
➤ Rigging	3rd & 4th 1996 U.S. Nationals

Featuring our Mylar Mag2 jib with glued seams, no stitching!

For more information on our sails, please contact us at:

Ullman Sails

410 - 29th Street
Newport Beach, California 92663
Phone - 714/675-6970
Fax - 714/675-6276
Email - ullman@ullmansails.com



District 6 Champs

Preview for Nationals

With the 1999 U.S. Nationals only two weeks away, the host Mission Bay Fleet 495 was holding the District 6 Championships on July 10 & 11 as the final tune up for both racers and race committee. The creative concept of having both bay and ocean racing as part of the Nationals was going to be put to the test for the first time at the Districts.

No one was holding their breath more than National's Regatta Chairman George Walker. "We designed the Nationals format because we believed it would give us the best chance of having a well attended event." The concept has had its detractors. Many felt that the lake-like course inside Mission Bay was too small, and that premier events like the Districts and Nationals deserve the open water, ocean course that exists off the shores of Mission Beach. Was it tradition speaking, or common sense?

After over a year of planning for the '99 Nationals, it was time to put the "if we build it they will come" concept to the test for the Districts. As registration closed, a healthy 40 boats were on the list, indicating to all that the varied course plan may just well be giving the people what they want. "District sailors know that this ocean course can have lighter, shifter winds than inside the bay, plus you have to contend with the kelp, possible seasickness and the longer sail out," says Walker. "We are very optimistic that by alternating course locations, we will be giving everyone enough of what they want without giving them too much of what they may not want."

Saturday had the fleet head out to the ocean course, site of the 1997 World Championships, for the first three races of the District Championships. Having not sailed on the course since winning the last race of the

Worlds, locals Craig and Lisa Leweck started the day with another win, and continued on with a 3-2.

The story of the day was the "bad race." Except for the Lewecks, everyone seemed to have one. After Team Tillson and Team Merriman posted a 2-3 respectively in race 1, they got gobbled up in race 2 with a 12-14 respectively. This is what the ocean course is famous for: humbling the heroes. By the end of the day, most of the top teams were already scoring with a drop race, and hoping for more consistent sailing on Sunday in the bay.

Course location in the bay depends on wind direction, and Sunday's westerly direction had the RC place the course at the north end. The right side of the course is marked by a long beach, which extends to windward until it curves to the left to form a cove. The weather mark is placed near the top of the cove, and the shifts provided on this course make it the most exciting place to sail on the bay. Racing at the north end of the bay is not for the faint of heart. Mistakes are magnified. You hesitate, you lose.

Team Leweck was feeling the heat in the first race. They rounded the first weather mark in the top three, but went on to jibe their way out of the top ten on the run. Finally finding form near the end of the race, they crawled back to sixth. However Team Merriman, known for their bay skills, had won the race, which put them 1.25 ahead on points (counting the drop race).

Merriman's reign was short lived as Team Leweck would rattle off a 1-1 in the final two races to secure their place as the 1999 District Champions. The format had worked, wherein both ocean racing and bay racing provided a great District championship, and would surely provide plenty of excitement for all those coming out to the Nationals.

—Craig Leweck

Skipper/Crew	Sail #	Finishes	Total
1. Craig/Lisa Leweck	29197	1-3-2-(6)-1-1	7.25
2. Rick/Carol Merriman	29222	3-(15)-1-1-4-2	10.5
3. George Szabo/Brian Janney	29672	(11)-1-8-2-7-4	21.75
4. Dave/Barbie Tillson	29112	2-12-3-4-(18)-7	28
5. Mike Lenkeit/Gus Wirth	28686	4-2-10-(15)-6-9	31
6. Chris Snow/Carol Cronins	29151	6-8-4-11-11-(17)	40
7. Doug Hart/Jeff Baker	29314	5-7-12-16-(23)-6	46
8. Jim Grubbs/Ruth Pauling	28446	9-16-6-(21)-5-11	47
9. Ken/Julie Redler	29315	(15)-11-14-12-14-3	54
10. Gavin/Holly O'Hare	29016	13-6-19-8-9-(22)	55
11. Carolyn Brown/Eric Krebs	28955	(23)-4-13-rdr-2-23	55
12. Gonzo Diaz/Graham Biehl	28812	8-9-7-23-(24)-14	61
13. Marc Barra/Lauren Maxam	8672	12-20-5-7-19-(30)	63
14. Don Bedford/Laura Nottoli	29013	7-14-18-13-(21)-13	65
15. Jerry Thompson/Parker Shinn	24702	14-19-25-(cnf)-3-10	71
16. Jerome Fournier/Julie Calvert	28679	(25)-17-11-14-8-24	74
17. Rick Ameson/Chris Wright	27569	22-5-15-18-15-(dnc)	75
18. John Jackman/Steve Stewart	29108	16-(21)-20-10-20-18	84
19. George/Ellen	28369	19-(30)-26-5-25-16	91
20. Jack/Abby Bateman	28333	18-22-9-22-(32)-20	91
21. Tom/Laurel O'Neill	28678	10-24-17-17-26-(dnc)	94
22. Chuck Sinks/Andrea Nilsen	28687	(dnc)-dnc-dnc-3-16-5	104
23. Bob Bowden/Joanne O'Dea	28223	17-(27)-21-26-22-19	105
24. Sean/Jerelyn Biehl	29104	(dnc)-cnf-22-25-10-21	109
25. Bill/Sherry Campbell	27377	(dnc)-dnc-dnc-9-13-8	110
26. Russell Oiring/Connor Herron	28858	29-28-14-19-(30)-15	115
27. Nick Wilden/Megan Houseweart	29242	26-33-(dnc)-cnf-17-21	126
28. Jack Franco/Bridget Shear	29702	20-10-16-(ocs)-dnc-dnc	126
29. Bob Jackman/Julie Lundstrom	29250	24-18-28-28-28-(31)	127
30. Tyler McKay/Tanner Marsh	29166	33-13-23-32-(dnf)-27	128
31. Vince Casalaina/Grace Fang	28856	28-29-27-(ocs)-27-25	136
32. Jonathan/Stefanie Carroll	25395	27-26-(dnf)-27-28-32	140
33. Kent Sisk/Julie	27928	30-25-(dnc)-33-31-26	145
34. Shawn/Debbie Bennett	26104	21-dnf-dnc-(dsq)-12-dnc	151
35. Joe Harvard/Katherine Neville	26615	34-34-29-29-(35)-229	155
36. Ken Manzoni/Heather McDonald	20332	(cnf)-36-31-30-34-28	159
37. Dave/Barbara Carroll	28224	(cnf)-31-32-31-33-33	160
38. Ava Moore/Terry White	25992	31-35-30-35-(37)-35	166
39. Jorge/Shelly Suarez	23753	32-37-33-(dnf)-36-34	172
40. Charles/Elizabeth Heimler	28447	dnf-32-(dnc)-dnc-dnc-dnc	189

Lillia Snipe

Working together with the world's best sailors, we thought, designed and built...

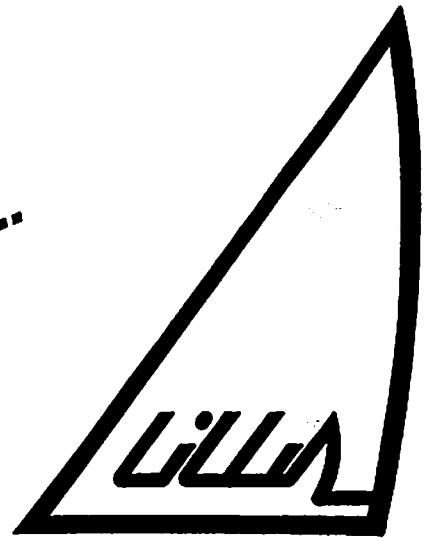

New Lillia Snipe

- Computer designed hull for the best all-around performance.
- Deck modified with the most comfortable hiking position.
- Deck hardware lay-out thought for more simplicity and access.

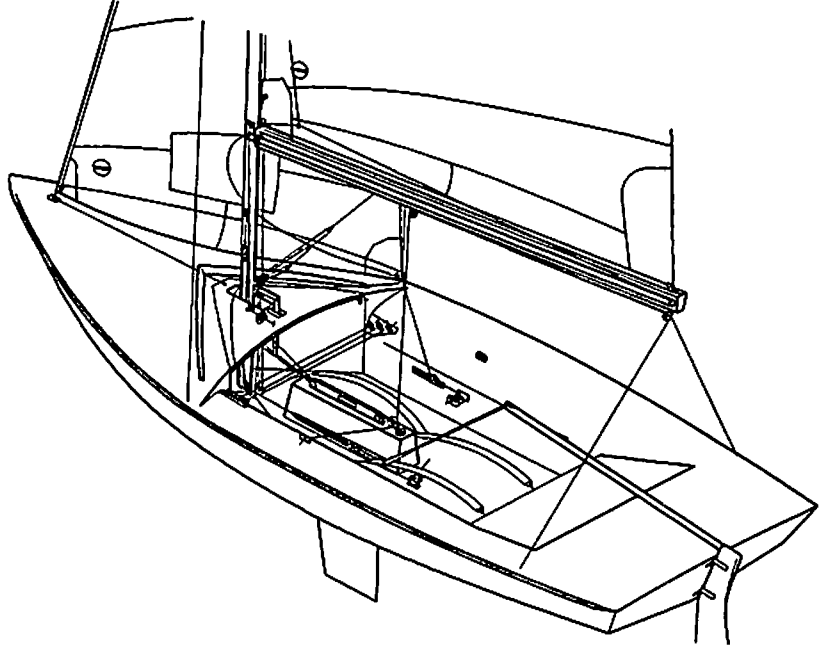

LILLIA BOATYARD - 22010 Musso - Como - Italy - Phone 0039-344-81223 Fax 0039-344-81568

LILLIA SOUTH AMERICA
Niterói - RJ
Phone - Fax 0055-21-616-2550

LILLIA NORTH AMERICA
190 Hagman Rd. - Winthrop, MA 02152
d- 617-539-0992 e-617-846-1772
Fax 617-539-0614