

***SNIPE***  
.....  
***BULLETIN***

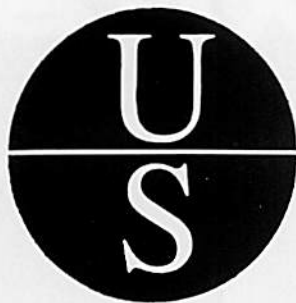

**AUGUST 1986**



# Ullman Sails Winning World Wide

## '85 RESULTS

1st Canadian Nationals	2nd US Nationals
1st Bahamian Nationals	3,4,5 World Championships
1st Spanish Championships	1st Wells Nationals
1st Norwegian Championships	1,2,3,4 Pacific Coast Championships
1st Scandanavian Championships	1st Southern
1,2,3,4 Masters Championships	1st Van Wesley Trophy
1st Junior Nationals	

## '86 RESULTS

1st Midwinters—5 Firsts  
1st Bacardi  
2nd Gamblin  
1st Overall Nassau  
1st '86 Midwinters West

## Make an investment in Performance.

Write or call Jeff Lenhart or Dave Ullman at:

ULLMAN SAILS, 410 29th St., Newport Beach, CA 92663, (714) 675-6970

Ullman Atlanta (404) 945-0788

Ullman Texas (214) 741-2364

Ullman East (516) 922-3422

Call for  
our full color  
catalog.

**PERFORMANCE  
EQUIPMENT  
FOR  
PERFORMANCE  
SAILORS**



Dinghy Spars & Hardware

Servo Cleats

Marlow

Yale

Henri Lloyd

O'Neill Wetsuits

Harken

Penguin

Holt Allen

Imhoff

Dry Suits

Lawrie Smith

Extra Sport

Lirakis Harnesses

Boots & Gloves

Warm Wear



**INTERNATIONAL  
SAILING PRODUCTS, Inc.**

ISP Annapolis Ltd.

318 Sixth St.

Annapolis, MD 21403

301-269-6160

ISP West

412 29th St.

Newport Beach, CA 92663

714-673-5774

Telex: 333091 ISP WEST



Order Toll Free

800-645-7676

In California

800-321-3137

ISP Inc.

P.O. Box 355

Oyster Bay, NY 11771

516-922-5182

Telex: 361007 INTSAIL

# The Fine Art Of Small Lake Sailing

*Part III — patience to adjust to varying wind directions and strengths is a virtue of the successful 'pond' sailor.*

*Craig Leweck, 1986 Zimmerman trophy winner, is also an expert on small lakes, having spent two seasons in District III's Lake Country before returning to California last year.*

by Craig Leweck

The fact that the conditions are anything but steady is the big reason why positions can change so quickly. As the breeze direction is fluctuating, the velocity that the breeze holds is also constantly in a state of fluctuation. While only some of the top sailors seem to consistently be on top of most of the shifts, it only takes a good set of eyes to see where the most breeze is.

During the drifting start of the last race of the Columbus Open in 1985, a huge veer left many of us at the now unfavored port end with only seconds to go. Those at the weather end gave no return address as they moved away with the new breeze and its superior angle. Now in the deep teens with the fleet densely packed around us, we decided to wait for the breeze to come to us since there were no axis lanes to get over to the right. As the wind became more solid over the lake, it backed to essentially its original direction. Those who started near us but slid over to the right were now way behind us and we only had to catch the 15 boats who jumped away with the original puff. No big deal, eh.

Well, as the fleet spread themselves out across the lake, we committed ourselves to the left for a couple of reasons. It was still real light so to tack was a fairly slow maneuver. We had felt good about the left side before this had all happened and we still thought that the wind was going to keep coming out of this one small bay on the left. Also, all the leaders had stayed to the right and were not showing anything great beyond what they initially received.

If the breeze were to mature and become solid, it was going to come in from a side and be strongest at that point. The port tack was now the closer tack to the mark, and those on port on our side were pointing a touch higher than those in the middle of the course. It was a calculated risk that we had made by digging into one side, but we had so often learned that aggressive tactics during these flukey moments quite

often paid huge dividends. That is, if we are right.

We had positioned ourselves just underneath the port tack layline which was just over a hundred yards away from the weather mark. We had been going fairly well and had worked up to about ninth place. No one was farther left than we were. As we had slowly manipulated our boat up this first leg, a fair pod of ripples were working their way out of our cove. We were going to look like gods if we pulled this recovery off, and there was no reason for another breeze to pull the right in ahead of us. As we got more hints of this new breeze, we moved more players behind us as we drifted along in about sixth.

There was definitely a lot more breeze to come from the left, but we were now cracked out a bit as we honed in on the mark. As Bob Rowland, who was directly behind us (also on port) tacked to starboard to go for the breeze, we questioned his thinking. When easily laying the mark, he tacks to a course that is now taking him away from the flag just so he can get more wind. Though we were still coasting along in glassy water with some serious ripples

in our weather side, we felt the angle that it would take to get it was too severe. We also were quite pleased on how we were doing on the boats to the right, and we were not about to risk what we had gained. I guess he felt that the chance of losing boats was small in light of the opportunity to make the big gainer.

As he now tacked to port in the new breeze, he was well back on our weather hip. At least that is where he started. He soon zoomed by us and the rest of the fleet to led at the weather mark. We rounded in about fifth after learning this huge lesson about going for the breeze.



We used this knowledge for the rest of the race to eventually lead the fleet. How did we finally end up? Fourth, because we thought the wind was going to come off the right shore for the last weather leg. It didn't, so the first three boats behind us got by as they capitalized as we had on the ripples that kept coming out of that one cove on the left. So much for newly learned lessons being certified in cement.

The time that I have spent sailing in the small lakes has definitely benefited my sailing on the whole. The opportunity to compete against many of the classes' established sailors who have sailed exclusively in the ponds has taught me a great deal about short course tactics and shift predicting. With this year's nationals being held at Chautauqua Lake, we definitely are going to experience some of these small lake type conditions. So remember — a good memory, a patient attitude and a penchant for abuse will hopefully bring good fortune your way as you oppose this fickle opponent, the small lake.

## 3 COVERS IN 1

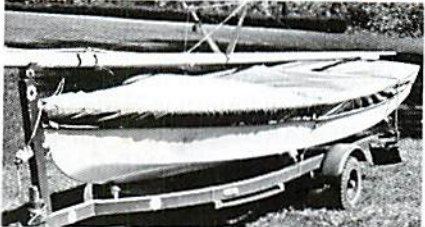

### IN STOCK FOR IMMEDIATE DELIVERY!

**FULL DECK TRAILING & MOORING COVER**  
(3 photos above)

- Can be trailed or used with mast up
- Extra reinforcement at all stress points
- 5/16" elastic shock cord in hem under rubrail
- Heavy duty nylon zipper
- Loops for under hull straps

CANVAS or NYLON or POLYESTER \$158<sup>00</sup> ppd.  
YACHTCRILLIC White \$164<sup>00</sup> ppd., Color \$176<sup>00</sup> ppd.

**FOOTBALL SHAPE COCKPIT BAG** \$12<sup>00</sup> ppd.  
• Hangs tied into cockpit, zips closed, clear see-through panel

**BOTTOM COVER** \$157<sup>00</sup> ppd.  
• Flannel lined waterproof grey canvas with drainhole  
• Fits with shock cord in hem that clings to deck

**DAGGERBOARD COVER** \$26.00 ppd.  
• Flannel lined canvas • Specify size & shape

**RUDDER COVER**  
• Flannel lined canvas \$21<sup>00</sup> ppd.  
• Foam lined nylon \$31<sup>00</sup> ppd.

**Satisfaction Guaranteed**  
Send check to:

**THE SAILORS' TAILOR**  
191 Bellecrest, Bellbrook, OH 45305  
Bob Rowland 513-848-4016

OR see Bob, Sandy, or Scott  
in Snipe No. 26303 & No. 24272.

# SNIFE BULLETIN

(USPS 611-500)

SNIFE CLASS  
INTERNATIONAL RACING  
ASSOCIATION

AUGUST 1986

Volume XXXV No. 8

## S.C.I.R.A OFFICERS

### Commodore

Wayne Soares  
P.O. Box 327  
Devonshire 4  
Bermuda

### Vice Commodore

Jerry Thompson  
79 - 63rd Place  
Long Beach, California 90803

### Rear Commodore

Per-Ole Holm  
OY Auto-Haro AB, PL 22 PB  
67101 Kokkola 10, Finland

### Executive Secretary/Treasurer

Lowry Lamb  
Privateer Road  
Hixson, Tennessee 37343

## RULES COMMITTEE

Chairman: Dan N. Williams  
MacLellan Building  
Chattanooga, TN 37402, USA

## EDITOR

Lowry Lamb

## EDITORIAL & BUSINESS OFFICE

Address all correspondence to:  
Privateer Road, Hixson, Tennessee  
37343, U.S.A.

TELEX: 5106013329 SCIRA

## PUBLICATION INFORMATION

Published monthly by Snipe Class International Racing Association, Incorporated, (not for profit).

Forms close on the 1st of the month preceding publication. Material received after that date will not appear until later month.

Printed in the U.S.A. at Chattanooga, Tennessee. Second-class postage paid at Hixson, Tennessee and at additional mailing offices.

## ADVERTISING

Contract rates furnished upon application.

## SUBSCRIPTION

\$8.00 per year. \$8.00 of the amount of dues in SCIRA are paid for a year's subscription to the SNIFE BULLETIN.

## CHANGE OF ADDRESS

Notify Snipe BULLETIN of any changes, both old and new addresses complete with zip code. Allow a month to become effective.

## Yachting Classes Named For Pan Am Games

The Pan American Yachting Organization (PAYO) and PAX/Indianapolis, Inc. announced May 2 the yachting classes that will participate in the 1987 Pan American Games.

The yachting venue is to be Michigan City, Indiana.

The classes so designated are Laser, Division II sailboard (to be selected), Snipe, Lightning, Star and Soling. There will be a separate event for men and women in the sailboard class. A full team will consist of 13 sailors.

This seven-event plan was adopted by the PAYO Executive Committee at a meeting in January, but not announced pending a request for reconsideration from the J/24 class. The request was given careful consideration by the five-member PAYO Executive Committee, which by majority vote adopted the original plan without change.

The members of the PAYO Executive Committee are: Denis Clemence (Brazil), Eduardo Rodriguez Game (Ecuador), Charles Kober (USA), Robert Sloane (Mexico), and Robin Tattersall (British Virgin Islands).

Contact: Sam Merrick, Secretary General for PAYO, 401 N. Street SW, Washington, DC 20024. (202) 554-4979.

## Afterguard '86 Beckons Former Collegiate Sailors

The Inter-Collegiate Yacht Racing Association invites former college sailors to Afterguard '86, a regatta aimed at reviving The Afterguard, a group founded in the late 1940s for former collegiate sailors. The regatta is scheduled for the Charles River Basin, Boston, MA, September 6-7, 1986.

Goals of The Afterguard include competition and fellowship, as well as improvement in college sailing, service as race administrators and judges, fund raising, etc.

Advance registration is required for the regatta. For information write: ICYRA AFTERGUARD '86, c/o White, 228 Claude St., Annapolis, MD 21401. Tel (301) 263-0743.

## LETTERS

Buzz:

...Northeasterns at Buffalo Canoe Club (see report) were bedeviled by light air and fog for most of the weekend, but five races were completed. Matt and Lisa Fisher won with Steve Callison and Andrea Tomaselli



Snipes, shown racing in Argentina during the 1985 World Championship, will be one of six classes in the 1987 Pan Am Games. Racing will be on Lake Michigan near Michigan City, Indiana. Buzz Lamb photo.

second, and Fred and Jan Rozelle third. Tom Allen Sr., tailed too! There were 29 boats. My results not so good 14-15-20-NS (over early)-22, and when I mess up as in race five it is really good — pole lost on run, fouled boat on run, hit mark — had been sixth at the top of second weather leg. C'est la vie!

Chris Hains  
F.C. Oakville Fleet 321

Dear Buzz:

... We are registering Scott Hughes' boat as a wedding present to him. He recently became the Democratic nominee for congress from his district.

Sigrid Festersen  
Iowa-Nebraska Fleet 309

Editor's Note: The Snipe BULLETIN doesn't usually make political endorsements — but this is an exception. Vote for Hughes!

## THE COVER

Summertime and the Snipe van! Time to go to a regatta! David Cox photo.

## THE SCORE

Five numbers were issued this month and all went to Brazil. Fleet Charter 799 went to Ocean City, Maryland. This is another fleet where the Annapolis fleet assisted. Congratulations to all the new members and the best of luck to the fleet.

Numbered SNIPES — 26656  
Chartered Fleets — 799

# What A Year!

Shore Sails' customers dominate the SCIRA National and North American Championships!

## 1985 SCIRA NATIONALS

Heinzerling	3,4,5	Six out of top ten
Wells		Seven out of top ten
Crosby		Five out of top ten
Junior		3rd

## 1985 NORTH AMERICANS

1st, 3rd — first in every race, more sails in the top ten than any other sailmaker!

That's not all . . . Look at these results!

1985 District I — 1,3	1985 District II — 2,4,6
1985 District III — 1,2,3,4	1985 District IV — 1,4
1985 Southernns — 2,3,5,7	1985 Atlantic Coasts — 1,2,5,6
1985 Northeasterns — 2,3,4,5	1985 Bermuda Race Week — 2
1985 Midwinters — 2	

Let us add you to the list in 1986! Consider us your personal sailmakers!

Call or write  
Greg Fisher, Bertie Gerling or Chris Varvarosky

**WE WILL  
HELP YOU  
WIN.**



# SHORE SAILS

330 West Spring Street  
Columbus, Ohio 43215  
(614) 221-2410

Other lofts in: Huntington, NY; Traverse City, MI; Aichi, Japan; St. Thomas, U.S. Virgin Islands; Newport, RI; Point Pleasant Beach, NJ; Winooski, VT; Annapolis, MD; Cleveland, OH; Houston, TX; Seattle, WA; Portland, ME.



"A" Fleet top 10, skippers from left: Greg Fisher, Tom Craig, Matt Fisher, Scott Cline, Matt Gregory, Bill Simons, Brent McKenzie, Dave Pritchard, Hal Gilreath, Steve Callison. Crews: Jennifer Gordon, Ann Denes, Lisa Fisher, Alan Carscaddon, Holly Gregory, Sherry Simons, Sharon McKenzie, Mike Lenkeit, Shawn Burke, Patricia Fowler.

## McKenzies Are Tops At Southern

Brent and Sharon McKenzie, Lake Lanier, GA, are 1986 Snipe Southern Champions, continuing a winning streak begun at the Redneck the week before. Lookout District IV!

Consistency was the key. Brent and Sharon finished 3-4-5, four points ahead of Hal Gilreath and Shawn Burke, who finished 10-2-4, in the 42 boat "A" fleet. Matt and Lisa Fisher, Hoover, Lake, OH, Steve Callison and Patricia Fowler, Newport, NY, and defending champions Dave Pritchard and Mike Lenkeit of Lake Lanier, rounded out the top five places.

Chickamauga Lake, setting for the traditional Mother's Day weekend regatta, sponsored by Chattanooga's Privateer Fleet 142, featured the usual winds; 8 to 12 and tricky, for the two Saturday races. Sunday was also traditional, ending in a drifter, mercifully shortened by R.C. chairman Spike Carscaddon.

Conversation on Friday night centered on doubts of launching the boats in the lake shrunken by a prolonged drought. But on



"B" Fleet, from left, rear: Ken Haney, Jane Woolley, Mike Hackbarth. Front: Lyn Haney, Rand Woolley, Don Hackbarth. Not present Chris and Mary Varvarosky, and Bruce McPhee and Jim Henderson.

Saturday morning the puddle dredged under the hoist was big enough to accommodate a Snipe, and boats could be launched from the ramp in the usual manner.

Juniors had as much wind as they could stand, when a southerly blew up on Satur-

day morning with gusty winds of 15 to 18. Racing was close, with Mike Lenkeit, Lake Lanier, edging out local favorite Alan Carscaddon.

Kathy and Jeannie Bronaugh are 1986 Southern Snipe Women's Champions, by a boat length over Jane Woolley and

### SOUTHERN SNIPE CHAMPIONSHIP Stars — A Fleet (Top 30 of 42 Entries)

Boat	Skipper/Crew	Club	Places	Points	Finish
25840	Brent McKenzie/Sharon McKenzie	Lake Lanier	3-4-5	12	1
25848	Hal Gilreath/Shawn Burke	AYC	10-2-4	16	2
23621	Matt Fisher/Lisa Fisher	Hoover	2-1-14	16.75	3
24608	Steve Callison/Patricia Fowler	Newport, NY	1-8-11	19.75	4
25951	David Pritchard/Mike Lenkeit	Lake Lanier	4-18-2	24	5
21212	Tom Craig/Anne Denes	Privateer	16-5-3	24	6
16109	Greg Fisher/Jennifer Gordon	Hoover	8-16-1	24.75	7
25321	Bill Simons/Sherry Simons	Privateer	12-7-7	26	8
26026	Matt Gregory/Holly Gregory	Privateer	9-3-15	27	9
24093	Scott Cline/Alan Carscaddon	Privateer	7-13-12	32	10
25735	John Walton/Ann Walton	Detroit	18-10-6	34	11
26309	Steve Burke/Linda Leeds	Lake Lanier	5-20-9	34	12
25434	Ed Craig/Yvonne Craig	Privateer	13-12-10	35	13
25888	James Evans/Amy DiGozzaldi	Hoover	6-14-18	38	14
25007	Tom Smith/Beth Smith	Lake Lanier	30-6-19	55	15
26100	Woody Norwood/Kat Munson	AYC	21-28-8	57	16
23619	Rob Spring/Joyce Spring	Mission Bay	11-9-nf	59	17
19091	Pete Duvoisin/Jeanne Duvoisin	Privateer	17-17-30	64	18
16104	John Muhlhausen/Kitza Muhlhausen	AYC	15-17-23	65	19
24122	Bill Hooper/Velda Hooper	AYC	26-22-20	68	20
24442	Buzz Lamb/Marge Lamb	Privateer	14-32-22	68	21
24264	Frank Pontious/Marilyn Pontious	AYC	22-35-13	70	22
24676	Jess Coburn/Taylor Grimsley	AYC	20-19-32	71	23
26995	Francis Seavy/Linda Duvoisin	Clearwater	25-25-25	75	24
25872	Paul Gillis/M.J. Gillis	AYC	23-26-26	75	25
23751	Tom Payne/Tom Schroeder	Lake Lanier	19-ns-17	78	26
26105	Ray Burke/Robb Ostrom	Lake Lanier	27-36-16	79	27
25125	Rob Fowler/Bruce Carscaddon	Privateer	39-11-29	79	28
24747	Dan Williams/Louise Cash	Privateer	24-23-34	81	29
26488	John Fry/Karin Fry	Annapolis	28-15-nf	82	30
24742	Ken Simons/Mark Garrett	Privateer	34-29-21	84	31
24699	John K. Ruff/John D. Ruff	AYC	32-24-28	84	32
23663	Skip Remter/Scott McCormack	Barefoot	29-30-31	90	33
24680	Bob Dean/Liane Dean	Clearwater	31-38-24	93	34
26306	Clay Hudgins/Carol Mammoser	Lake Lanier	35-21-27	93	35

### Bars — B Fleet

*24142	Mike Hackbarth/Don Hackbarth	AYC	1-3-1	4.75	1
26336	Chris Varvarosky/Mary Varvarosky	Hoover	3-2-2	7	2
21101	Jane Woolley/Rand Woolley	Privateer	2-1-5	7.75	3
24698	Bruce McPhee/Jim Henderson	Privateer	5-4-3	12	4
21794	Ken Haney/Lyn Haney	AYC	4-5-4	13	5

Juniors: 1. Mike Lenkeit, Lake Lanier; 2. Alan Carscaddon, PYC; 3. Mike Hackbarth, AYC.

Ladies: 1. Kathy Bronaugh, PYC; 2. Jane Woolley, PYC; 3. Patricia Fowler, PYC

\* Top Junior in the 1986 Southern: Mike Hackbarth, AYC.

Sherry Simons. This new feature race was sailed at the same time, and on the same course as the junior race.

Mike and Don Hackbarth, Atlanta Yacht Club, finished first in the "B" fleet, two and a quarter points ahead of Chris and Mary Varvarosky, Hoover, OH, in second. Local heroine Jane Woolley, with her son Rand as crew, was third after a hard drift in the last race. Bruce McPhee and Jim Henderson, of Privateer, and Ken and Lyn Haney, of Atlanta Barefoot, completed the trophy winners for the second division.

Mike Hackbarth also received the trophy for the top finishing junior skipper in the regatta.

Rob Fowler oversaw the steak dinner, and PYC Fleet Captain Tom Craig (who lost a tie-breaker for fifth place) was responsible for the LOUD music. Great fun. Y'all come back next year, Y'hear?

Marge Lamb  
Privateer Fleet 142

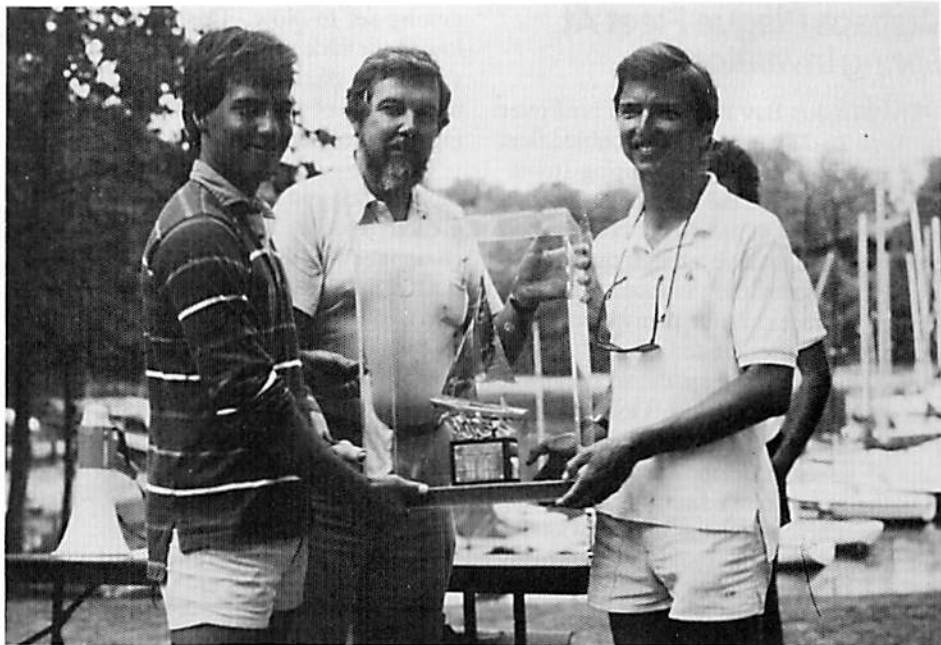

Brainard Cooper, center, presents the Van Wesley Trophy to crew Mike Lenkeit, and skipper Dave Pritchard.

## Dave Pritchard Wins Van Wesley Trophy

The Van Wesley Trophy, emblematic of the high point championship of District IV, was presented to Dave Pritchard and Mike Lenkeit at the Southern Snipe Championship May 11. Dave scored first place

finishes in the 1985 Southern, District IV Championship, and Hallowe'en Regatta.

The trophy, owned jointly by SCIRA and Privateer Yacht Club, is a memorial to Van Wesley, member of Fleet 142.



# TERMINAL VELOCITY

*velocity: 1. quickness of motion. 2. time rate of linear motion in a given direction.*

*We at Ulmer/Kolius cut sails with one goal in mind; to make your Snipe win races. Not only do we understand sails; we understand Snipes. Ulmer/Kolius sail designers have made a science of shaping Snipe sails for maximum speed in all conditions. You already know what our sails can do for big grand prix boats, now we turn our attention to Snipes.*

*Ulmer/Kolius has developed a new line of sails designed specifically to meet the performance demands of racing Snipes.*

*The sailmakers at the Ulmer/Kolius lofts have tested hundreds of different lots of dacron to determine the material best suited to give your Snipe a competitive edge. Our Snipe mainsail is made of 4.4 oz. dacron, the jib 3.3 oz. cloth. Both main and jib have state of the art radial corner*

*patches. Radial corner patches reduce wrinkles as well as reducing bulk which allows faster tacking.*

*We've studied Snipes so thoroughly that what we've learned could fill a book, so we wrote one, the comprehensive Snipe tuning guide. The tuning guide is presented with every suit of Ulmer/Kolius Snipe sails. Shoot for terminal velocity, Ulmer/Kolius sails.*

**THERE ISN'T  
A BOAT IN  
THE WORLD  
WE CAN'T  
MAKE  
FASTER.**



Please call Chris Snow at (301) 757-7575  
Ulmer/Kolius Maryland, 1610 Whitehall Road, Annapolis, Maryland 21401

## Mishaps Plague Fleet At Spring Invitational

The Mission Bay fleet played host over the April 26-27 weekend to a troubled fleet of 25 boats for the annual Spring Invitational. The tone for the regatta was set early on as many of the west coast's best sailors seemed to have a tough time avoiding bad breaks as they worked their way through the races. While many blamed the accidents on the United States' recent troubles in world politics, the scenario was all too familiar for the locals as they knew this weekend was going to be another regatta to go down in the record books.

As the racers moved out to the starting area, they noted that the breeze was farther west than normal and it was already

getting set to blow. This wind angle allowed the race committee to take full advantage of the length of the bay, much to the dismay of the sailors who were hoping to save themselves for the party.

This, however, was a small concern to Jack Franco and Renee Vesterby who had greater troubles to face. While the race committee was in the countdown sequence for the first race, Tom Nute (who was on port) got his mast tangled up with Franco's which resulted in the ultimate destruction of Jack's mainsail (he was able to borrow another to finish the series). Since it was Nute's spreader that did the damage, a topic of discussion was whether the venerable Nute was experimenting with the long spreaders.

A multiple windward-leeward course

was the call for much of the weekend, and for the first race Steve Bloemeke with crew Scott Lindley and the Craig Leweck/Lisa Manzer team took advantage of the heavily port favored line and port tack course to lead the fleet in that order.

While the crew weight of Bloemeke-Lindley favored them upwind in the extremely puffy 12-18 knot conditions, Leweck was able to gain enough offwind to keep the contest close. Bloemeke let the race get away after mistakenly rounding an improper windward mark, slipping to seventh while allowing Leweck to win with Keith Dodson/Karen Krull in second and Robb Walker/Rowena Carlson in third.

The breeze had established itself as a challenge by the second race, but it was not too overwhelming for Ray Treppa who took over the course for the win. Keith Dodson slid in again for second with Jeff Lenhart and Ramona Lampe claiming third.

Sailing among this top group was Steve Bloemeke until the last leeward leg, where he and Lindley did a crash capsized during one of the day's puffs. Despite the lack of survival suits being worn by the crew, they both miraculously endured the incident. It was just before the start of the third race that their mission was completed, as they had to drift down to Vacation Island (ap-

### SPRING INVITATIONAL (Top 10 of 25 Entries)

Skipper/Crew	Places	Points	Finish
Jeff Lenhart/Ramona Lampe	5-3-1-4-1	13.5	1
Craig Leweck/Lisa Manzer	1-7-7-2-2	18.75	2
Keith Dodson/Karen Krull	2-2-9-3-6	22	3
Robb Walker/Rowena Carlson	3-4-5-7-4	23	4
Ray Treppa/Big Person	13-1-3-8-9	33.75	5
MarkButler/Karen Butler	9-9-11-11-5	45	6
Andy Barnes/Marsha Rohan	8-dnf-8-6-3	48	7
Sean Biehl/Jerelyn Biehl	6-12-13-9-12	52	8
Steve Bloemeke/Scott Lindley	7-dnf-6-1-dns	54.75	9
Donald Krebs/Chuck Sinks	20-15-6-2-dnf	62	10

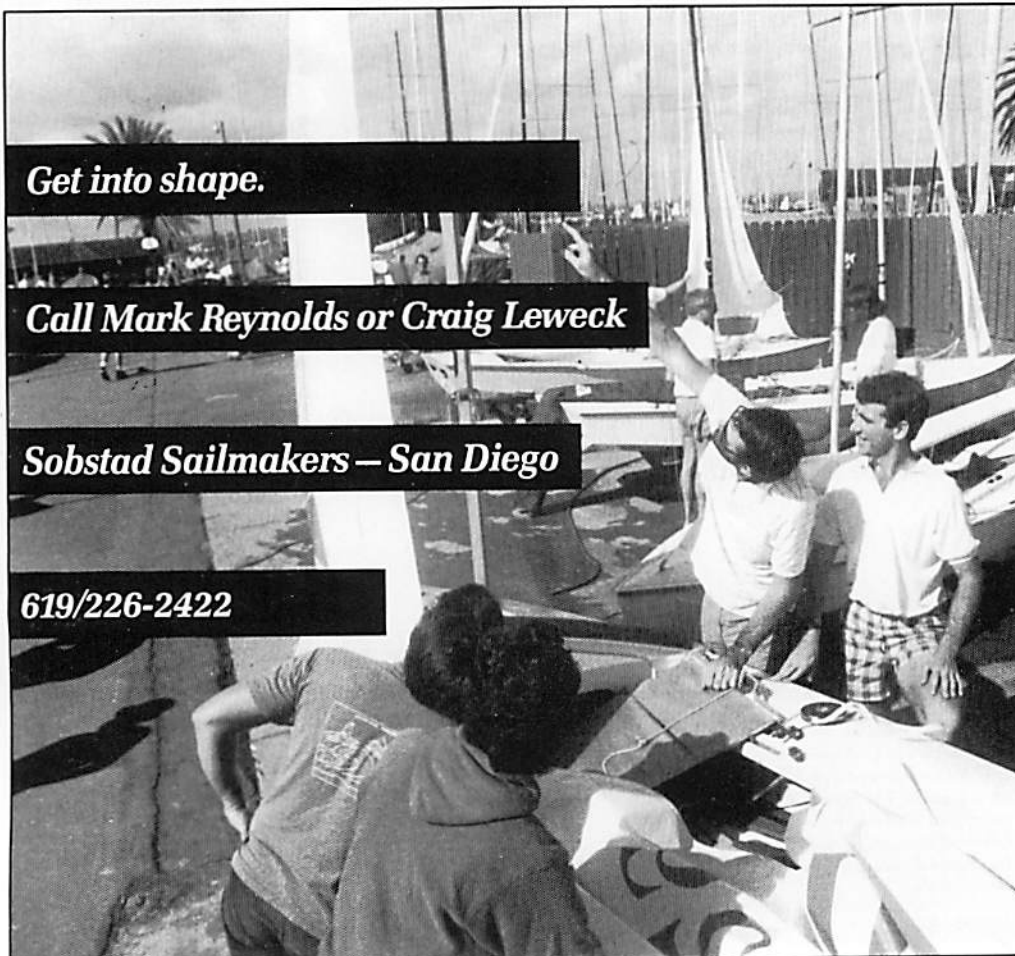

**Get into shape.**

**Call Mark Reynolds or Craig Leweck**

**Sobstad Sailmakers — San Diego**

**619/226-2422**

Get into shape. We are. Our commitment to develop sails that are responsive through the wind range while staying at top speed has kept our customers in the winner's circle. Join the Sobstad team and get into shape.

**Check the shape of these '86 results and give us a call. . .**

'86 Winter Circuit . . . . Overall Winner  
Kelly Trophy  
Nassau Circuit . . . 2, 3 and 5  
Concord Trophy . . . 1 and 2  
Southerns . . . . 2nd Overall

Sobstad — San Diego  
2832 Canon Street  
San Diego, CA 92106





prox. 100 yards to leeward of start line) to drain the hull.

Another casualty of the second race was Leweck, who inverted his mast during a mega-puff on the first offwind leg. He struggled through the race with his spreaders stuck forward (and the mast quite straight), and then it took much of the break time between the second and third race to properly realign the rig.

The start line and the course was still very much angled toward the port tack for the third race. This point joined with the fact that the breeze for the windward leg was semi-obstructed as it blew over a peninsula on the left side and saw most of the top boats coming out of the right side to lead at the first windward mark. Lenhart had seen these conditions before in his home waters of Mission Bay as he never looked back to eventually take the bullet.

The Donald Krebs/Chuck Sinks team held on for second, despite partially capsizing on one of the windward legs as crewman Sinks saw trouble in staying in the boat. The "Sinker" managed to keep it afloat though, and the pair regrouped for the deuce. In third was Treppa, who had a hard time believing that such a pair had ousted him.

(Continued on page 10)



Magnificent headgear for the winners: Ramona Lampe, Jeff Lenhart, Keith Dodson, Karen Kroll, Rob Walker, Rowena Carlson, Lisa Manzer, Craig Leweck, Ken Madsen and Ray Treppa.



# Scientific Sailboat Racing

Thoroughly revised and updated by Ted Wells and Lowry Lamb. Illustrated with diagrams and photographs. Since it was first published in 1950 and through one revision in 1958, *Scientific Sailboat Racing* has established itself as a classic of its kind for small-boat sailors. Now, it has been thoroughly overhauled to take advantage of the latest developments, particularly in equipment, that have come about in the last twenty years of sailboat design and handling.

\$10.95 Postpaid

SCIRA  
Privateer Road  
Hixson, TN  
37343

Skipper Snipe has dominated the European Circuit for 20 years



Now in the U.S.  
**SKIPPER  
SNIPE  
\$3995**

Ask about  
financing

**NO  
MONEY  
DOWN**

**FLEET DISCOUNT**

All prices subject to  
dollar value on  
World Market.

**SUGGESTED RETAIL PRICES:**

- ★ Snipe complete exclusive sails \$3995.00
- ★ Snipe complete exclusive mast boom and sails 3595.00
- ★ Hull without fittings 3395.00
- ★ Mast complete 475.00
- ★ Boom complete 135.00
- ★ Whisker pole 35.00
- ★ Trailer 395.00

All prices are FOB Baltimore, MD



*Scandinavian Yachts, Ltd.*

222 SEVERN AVE., ANNAPOLIS, MD 21403  
PHONE: (301) 267-0990

# Andersen Bailer

For more than twenty years the Bailer has been produced and developed by Andersen-Scandinavia. Previously sold under the name Elvstrom, the ANDERSEN BAILER is world famous for its functional design and high quality.

5 models  
stainless steel construction

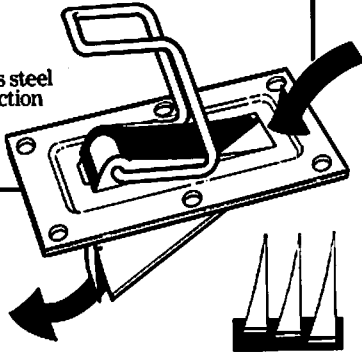

ANDERSEN STAINLESS U.S.A.  
Box 13015, 3301 S.E. 14th Avenue  
Ft. Lauderdale, Florida 33316-305-525-7537

**SUPPORT YOUR  
SNIPE ADVERTISERS**

## Spring Invitational . . .

(Continued from page 9)

As the tail of the fleet cruised over to the hoist area to pull their boats, the front runners of the pack were well on their way to party town as some serious snacks and beer kegs lay awaiting on the porch of Mission Bay YC. One glance at the faces of the crowd showed much of the long day on the course, but as soon as the members of the Rawtones band began bringing in their equipment the sailors started to search for their second wind. It was no secret that the dance floor was going to get worked this night, so the group slowly began to filter away to get geared up for the night to come.

Well, Sunday morning came obviously much too soon for many of the folks that began going through their pre-race routine. Fortunately, it looked as if the weary might get some reprieve from the "blistering" conditions of the day before as a gentle breeze appeared to be holding in wait for the first race of the day.

For those who could still do math, the point totals had Lenhart in first with 8.75, Robb Walker 12, Keith Dodson 13, Craig Leweck 14.75, and Ray Treppa with 16.75. The first race saw the rejuvenated

team of Bloemeke and Lindley blaze off to an early lead. Bloemeke's confidence for the tides and shifts of Mission Bay gave him enough distance on Leweck in the first half of the race to prevent the grinding "Little Creature" from overtaking him. Steady "Tree" Dodson held on for the third with "Jefe" Lenhart in fourth and Franco in fifth. Walker had to eat a seventh while Treppa munched an eighth.

In the end it was the veteran Lenhart who won the last race and the regatta. Leweck's second place in the last race concluded his comeback routine, which brought him up to the bridesmaid slot for the event. Dodson's last race sixth held him at third in the series, with Walker and Treppa filling in the remaining top five slots in that order.

Another Spring Invitational Regatta concluded on a very successful note, and much of the thanks must be directed to RC Chairman Steve Ross. His efforts certainly gained him kudos from the crowd. It is the photo of the top five that really illustrates the sentiments of the sailors from the weekend, as the necessary head gear is shown here to protect against the escape of any more enjoyment. Snipe sailors just want to have fun.

Craig Leweck  
Mission Bay Fleet 495

### LAKE QUASSAPAUG YACHT CLUB'S BOARD OF GOVERNOR'S REGATTA

WHEN: August 23rd & 24th, 1986

WHERE: Lake Quassapaug, Middlebury, CT

Beer, soda and set-ups provided all weekend. Friday night will start the weekend with a welcoming reception. Saturday, racing will begin, followed by one of Quassapaug's patented bashes which includes steak dinner, free flowing beer and plenty of entertainment. On Sunday, racing will be concluded

followed by a presentation to the top five skippers and crews.

A Junior Regatta will be held Saturday morning at 9:00 a.m. Only the Skipper must meet the Junior age requirement.

HOUSING — Limited availability for those who call in advance

CAMPING — Plenty of room at the club

LUNCHES — Available both days for a nominal fee

#### PREREGISTRATION FORM

The entrance fee is \$40.00 on the day of the Regatta, or \$35.00 for preregistered sailors. To register in advance, fill out the rest of this form and mail it to the address below by August 16th.

Senior Skipper's Name \_\_\_\_\_

Crew \_\_\_\_\_

Boat Number \_\_\_\_\_ Club \_\_\_\_\_

Senior Skipper's Address \_\_\_\_\_

Fee: \$35.00 which includes two (2) dinner tickets

Extra Dinner tickets \$15.00 \_\_\_\_\_

Total Enclosed \$ \_\_\_\_\_

Send To: Dave Rogers, Jr., P.O. Box 267, Naugatuck, CT 06770, (203) 755-4446, OR Lou Aquavia, 61 Thorson Road, Oxford, CT 06483, (203) 888-0074 (Home), (203) 576-1904 (Work)



Skippers, back row, L to R: Henry Davis, Steve Sherman, Doug Goppert, Gene Soltero, Doug Day, Ted Wells, James Rix. Crews: Mike Recker, Mike Sherman, Rita Goppert, Ann Fritts, Bret Voitenko, Bob Fugit, Ken Rix.

## Henry Davis Wins At Lake Lotawana, Again

As you're deciding which regattas to attend this season, don't miss this one, as Snipe Fleet 49 is celebrating 50 years of Snipe sailing on Lake Lotawana.

A great Joe Ramel Memorial Regatta held at Lake Lotawana, MO, September 14-15 was proud to host Snipe sailors from seven states. The competition was excellent, as six of the top eight boats had won at least one regatta in the previous 16 months. The entertainment was fantastic and started Friday evening with a complimentary cocktail party complete with

plenty of food and a video of the '83 America's Cup races ... from the Australian viewpoint!

Saturday morning began with a hotly contested junior race. District 2 junior champion Mark Frashier, finishing third, found tough competition with Mike Sherman and Bret Voitenko. Bret won the race, which was only the second Snipe race he had ever skippered. (By the way, he won the other one, too!)

After lunch, the seniors' first race started in light shifty easterly breezes. A large wind shift minutes after the start favored the port side of the fleet and a group of

*(Continued on page 12)*

### JOE RAMEL MEMORIAL REGATTA (Top 15 of 22 Entries)

Boat	Skipper/Crew	Fleet	Places	Points	Finish
24101	Henry Davis/Mike Recker	INSA	1-1-1	2.25	1
25514	Steve Sherman/Mike Sherman	WRSC	2-2-4	8	2
25075	Doug Goppert/Rita Goppert	MYC	4-3-3	10	3
25196	Gene Soltero/Ann Fritts	WRSC	3-13-2	18	4
25950	Doug Day/Bret Voitenko	MYC	7-4-7	18	5
25025	Ted Wells/Bob Fugit	WSC	8-5-6	19	6
25285	James Rix/Ken Rix	WSC	6-6-8	20	7
23822	Jon Skoog/Susan Marchese	INSA	10-7-5	22	8
23756	Chuck Falkenberg/K. Falkenberg	MYC	5-8-12	25	9
20013	Martin Bebb/Michael Bebb	Muskogee	9-9-9	27	10
24330	Bob Peugh/Jane Peugh	WSC	11-11-10	32	11
24111	Lou Joline/Sonja Joline	MYC	14-17-13	44	12
25652	Bob Ewoldt/John Layman	Lincoln	19-12-15	46	13
24104	Richard Evnen/Susan Evnen	Lincoln	20-10-16	46	14
23340	Scott Hughes/Peggy Ricke	INSA	15-14-17	46	15
<b>"B" Fleet (Top 5 of 8 Boats)</b>					
19585	John Barger/Gary Pierce	WSC	1-1-1	2.25	1
24222	Jack Vermillion	Topeka	2-3-2	7	2
22539	David Pierce/Chris Ridder	WSC	3-2-6	11	3
10605	Mark Frashier/Jim Martin	MYC	4-6-3	13	4
20934	Tom Duckworth/J. Falkenberg	WRSC	7-4-4	15	5
<b>Juniors (Top 3 of 6 Boats)</b>					
25950	Bret Voitenko/Doug Day	MYC	1	.75	1
25514	Mike Sherman/Steve Sherman	WRSC	2	2	2
10605	Mark Frashier/Jim Martin	MYC	3	3	3

## Advertise Your Class



(1/2 actual size)

Decals for Inside Glass and Pressure Stickers for Outside With the Snipe Emblem

75c each or 3 for \$2.00

SCIRA  
Privateer Road  
Hixson, Tennessee 37343  
U.S. A.



*We build the fastest Snipes ... in the world!*

4737 Adams Road  
Hixson, TN 37343  
(615) 875-4040

MIKE  
McLAUGHLIN



### Snipe Building Plans

BLUEPRINTS — \$15.00  
Revised January 1976

SCIRA  
Privateer Road, Hixson, TN 37343

## Class Pins!

Show pride in YOUR class. Wear a colorful Snipe emblem pin and let the world know you sail the most popular, challenging and fun one-design ever! Enameled, 5/8" x 3/4" pins are available for \$4.00 ppd. from the SCIRA office. (Make check payable to SCIRA.) Specify safety pin or push pin fastener.

## COBRA MASTS



*Obviously the  
Best Mast!*

**PACESETTER BOAT CO.**

6415 Grubb Road  
Hixson, TN 37343

(615) 877-7099



Think Snipe!



*Skippers, back row, L to R: John Barger, Jack Vermillion, David Pierce. Crews: Gary Pierce, No Identification, Chris Ridder.*

# North American Championship



San Francisco Bay  
Richmond Yacht Club  
September 24 - 27

### SCHEDULE

- **Wednesday:** Measurement and Registration, Practice Race, Mexican Fiesta
- **Thursday:** Registration, Skippers Meeting, Racing, Oriental Dinner
- **Friday:** Racing, Beer Tasting, "Cook Your Own" Dinner
- **Saturday:** Pancake Breakfast, Racing, Awards Banquet

*Other fun activities planned for landlubbers.*

### REGISTRATION FORM

Fee: \$35.00 prior to Sept. 1. Late registration \$50.00. Payable to Fleet 12.  
Mail to: Dick Loomis, 22 Debbie Way, Calistoga, California 94515, (707) 942-4006.  
Please Print:

Skipper \_\_\_\_\_ Crew \_\_\_\_\_

Address \_\_\_\_\_

Yacht Club \_\_\_\_\_ Fleet # \_\_\_\_\_ Sail # \_\_\_\_\_

All boats must conform to SCIRA measurements. Boats will be spot-checked for safety requirements. I certify that I am a member in good standing and that my boat conforms to all SCIRA requirements. I hereby agree to abide by all Snipe Class and USYRU rules, and release USRYU, SCIRA and Richmond Yacht Club, their officers, members, employees and members of the Race Committee from all liability by reason of injury, whether to the yacht entered above or to myself, my crew or my guests.

Signed \_\_\_\_\_ Date \_\_\_\_\_

## Davis Wins Again . . .

*(Continued from page 11)*

boats popped out in front. Henry Davis, Steve Sherman, Gene Soltero, Doug Goppert and Chuck Falkenberg were the first five throughout the race although the shifty winds kept juggling the order.

The second race saw a shift to starboard after the start and, again, Henry Davis, Steve Sherman and Doug Goppert led the pack battling all the way to the finish. Doug Day and Ted Wells rounded out the top five, dueling all the way up the last beat.

The Saturday night dinner held upstairs at the Missouri Yacht Club offered a predinner movie of the Long Beach sailing Olympics while the local Snipe sailors were cooking the kabobs over the charcoals. After dinner the live entertainment provided music for dancing and enjoyment on a beautiful starlit fall night.

Sunday morning saw light winds from the south and an eager Steve Sherman who needed a victory, plus a fourth from Henry Davis, in order to overtake Henry and win the regatta. Henry doused those hopes by nailing down another first, giving him three firsts and another Joe Ramel Memorial Regatta win.

In the B fleet, John Barger also took three firsts. This was quite impressive since it was John's rookie season with the Wichita fleet and his first trip to Lake Lotawana.

With jolly socializing, fair weather and stiff competition the entire weekend was memorable, especially for Bret, John and Henry.

## Dave Chapin Tops E.E. Manning Regatta

With 25 boats on the starting line, the Snipe fleet was the second largest class racing at Alamitos Bay YC on January 25-26 (Superbowl weekend). Winds were light and flukey, with a three hour wait for a breeze on Sunday.

Dave Chapin dominated the regatta winning three out of five races, and finishing ahead of second place Chris Raab by 9½ points.

*From District VI Newsletter*

## Columbia Reports Two Championships

The 1985 National Championship was sailed in Lake Tomine on August 17-19 at Club Nautico El Portillo, with the following results:

Skipper/Crew	Points	Finish
Andres Lisocki/Felipe Lisocki	20	1
Rafael Tamayo/Gustavo Tamayo	31.4	2
Carlos Ortiz/Antonio Tamayo	45.7	3
Manuel Isaza/Camila Isaza	47.4	4
Juan Uzcategui/Jurgen Hoebreker	54.7	5
Roberto Londono/Pedro Londono	58.7	6
Jorge Uzcategui/Stella Uzcategui	71.7	7
Juan Hernandez/Jaime Hernandez	77.4	8

## E.E. MANNING REGATTA (Top 5 of 25 Entries)

Skipper	Fleet	Places	Points	Finish
Dave Chapin	Alamitos Bay	2-1-1-1-3	7.25	1
Chris Raab	HHYC	7-2-2-5-1	16.75	2
Keith Dodson	Alamitos Bay	3-10-3-2-11	29	3
Craig Leweck	Mission Bay	12-3-11-3-2	31	4
Peter Newbre	BCYC	8-4-9-6-4	31	5

Felipe Castillo/Beatriz Cuervo	80	9
Santiago Uzcategui/E. Hoebreker	89.7	10
Carlos Orozco/Jose Gonzalez	91	11
Jairo Sanchez/Maria Velandia	100.7	12
Santiago Lombana/H. Breslauer	101	13
Jaime Castillo/Juan Castillo	115	14

## 1986 Junior National . . .

With the participation of four boats, we held a Junior National Championship at Club Nautico del Muna on April 26-27, with the following results:

Skipper/Crew	Points	Finish
Camila Isaza/Daniel Cuervo	4.25	1
Felipe Castillo/Beatriz Cuervo	11	2
Catalina Deeb/Marcela Recaman	11.75	3
Mauricio Ortiz/Michael Herold	13	4

Camila Isaza, as skipper, and Felipe Castillo, as crew, are planning to attend the Junior World Championship in Italy next July.

*Cabriel Cuervo*  
*SCIRA National Secretary,*  
*Columbia*

## BOAT LUMBER

For Fine Boat Building  
and Repairs

SITKA SPRUCE MAST  
& SPAR GRADE

PHILIPPINE  
MAHOAGNY

HONDURAS  
MAHOAGNY

WESTERN RED  
CEDAR

WHITE CEDAR

OAK · TEAK · CYPRESS

LONG LEAF YELLOW

PINE · ETC.

Fir and Mahogany Plywood for marine use  
lengths up to 16 feet. Bruynzeel Marine Plywood,  
solid Regina Mahogany throughout. Quality un-  
surpassed. Most sizes in stock.

Ripping and planning to order.

We are specialists in all types and sizes of  
imported and domestic boat lumbers. We  
ship anywhere - at surprisingly low prices.  
Send 10¢ today for valuable manual "How  
to Select the Right Boat Lumber" plus  
complete lumber and price list.

**M. L. CONDON CO.**

BOAT LUMBER SPECIALISTS SINCE 1912

236 Ferris Ave., White Plains, N.Y. 10603

(914) 946-4111



## Sanctioned Snipe Regattas

AUGUST 2-3, SUNFLOWER REGATTA, Shawnee Fleet 597, Delmar Tucking, 5145 NW 35th, Topeka, KS 66618.

AUGUST 2-3, BROADSTAIRS OPEN, Broadstairs, Kent, John Broughton, 24 Empress Dr., Chislehurst, Kent, BR7 5BD England.

AUGUST 9-10, DISTRICT III JUNIOR CHAMPIONSHIP (Open to all SCIRA Jrs), Indianapolis Fleet 409, Paul Dovey, 7566 Castleton Farms W. Dr., Indianapolis, IN 46256.

AUGUST 14-17, NATIONAL CHAMPIONSHIP, FINLAND, Tampere, Finland, Roger Nyland, Osterlangatan 9 B 28, SF-20520 ABO, Finland.

AUGUST 15-17, GOLD CUP, Juelsminde, Jylland, Denmark, Niels Kampmann, Teglgard-vej 3, 2920 Charlottenlund, Denmark.

AUGUST 16-17, NEW YORK STATE (OPEN), Newport 103, Steve Callison, 193 Rossiter Rd., Rochester, NY 14620. Home (716) 473-2478.

AUGUST 23-24, BOARD OF GOVERNORS REGATTA, Quassapaug Fleet 231, Michael Elser, 517 Allerton Rd., Naugatuck, CT 06770. (203) 758-8435.

AUGUST 23-24, CAMPIONATO ADRIATICO SNIPE, CN Chioggia, Calle Santa Croce 1221/A, 30015 Chioggia, Italy.

SEPTEMBER 6-7, LONG ISLAND CALL-OF-FALL, Sea Cliff Fleet 4, Jack Williams, 25 Orchard St., Glen Head, NY 11545.

SEPTEMBER 6-7, BIRD BATH, Muscle Shoals Fleet 784, William J. Parkhurst, 303 Oakhill Ave.,

Sheffield, AL 35660.

SEPTEMBER 6-7, INDIANA OPEN, Indianapolis Fleet 409, Randy Fridlund, 509 N. Ritter, Indianapolis, IN 46219.

SEPTEMBER 6-7, RONALD PRIME MEMORIAL, North Cove 127, Arthur Cunningham, 136 North Shore Rd., Derry, NH 03038.

SEPTEMBER 6-13, XIX CAMPEONATO DE EUROPA, Real Club De Regattas, Santiago De La Ribera, Murcia, Spain. Telephones: 968-570250 and 968-570254.

SEPTEMBER 13-14, COLUMBUS OPEN, Hoover Fleet 760, Brad Warne, 7000 Constitution Pl., Worthington, OH 43085.

SEPTEMBER 13-14, JOE RAMEL MEMORIAL REGATTA, Missouri YC Fleet 49, Ken Frashier, L-84, Lake Lotawana, MO 64063.

SEPTEMBER 13-14, VIKING SNIPE, Vestfjorden, Norway, Birger Jansen, Skogveien 51C, N-1320 Stabekk, Norway.

SEPTEMBER 17-19, SNIPE MASTERS WORLD CHAMPIONSHIP, Atlanta Fleet 330, John Muhlhause, 1146 Green St., Roswell, GA 30075. (404) 642-1146.

SEPTEMBER 20-21, TROFEO AVAV, AVAV Luino, Renato Suttora, Via di Castelvetro, 2, 20100 Milano, Italy.

SEPTEMBER 20-21, U.K. NORTHWEST CHAMPIONSHIP, Budworth S.C., Budworth, Cheshire, England. John Broughton, 24 Empress Dr., Chislehurst, Kent, BR7 5BD England.

SEPTEMBER 20-21, OHIO (OPEN) STATE CHAMPIONSHIP, Chippewa Fleet 621, Dick Ravetta, 552 West St., Wadsworth, OH 44281.

SEPTEMBER 20-21, MYSTIC LAKE OPEN, Medford Fleet 777, Martin Fraser, 120 Eldridge St. #5, Tawnton, MA 02780.

SEPTEMBER 20-21, STOCKHOLM OPEN, Tomas Franzen, Skrinvagen 17, S-177 44 Enskede, Sweden.

SEPTEMBER 24-28, NORTH AMERICAN CHAMPIONSHIP, San Francisco Fleet 12, Dick Loomis, 2429 Debbie Way Calistoga, CA 94515.

SEPTEMBER 27-28, OXFORD INCIDENT/AC-CIDENT, Acton Lake Fleet 515, Jay Antenen, 5853 Headgates Rd., Hamilton, OH 45011.

SEPTEMBER 27-28, BATTLE OF ATLANTA, Lake Lanier Fleet 781, James Howard, 3202 Stratford Green Ct., Avondale Estate, GA 30002.

OCTOBER 4-5, MIDWEST CHAMPIONSHIP, Wichita Fleet 93, Robert B. Peugh, 1440 East English, Wichita, KS 67211.

OCTOBER 4-5, FRIGID DIGIT, Annapolis Fleet 532, John Fry, 3001 Veazey Terrace #1630, Washington, DC 20008.

\*OCTOBER 4-5, RIFF-RAFF, Cowan Lake Fleet 433, Timothy S. Black, PO Box 6464, Cincinnati, OH 45201

OCTOBER 11-17, WESTERN HEMISPHERE CHAMPIONSHIP, Fujiya Matsumoto, Japan Yachting Association, 1-1-1 Jinnan, Snhibuyaku, Tokyo, Japan.

OCTOBER 26-27, HALLOWEEN REGATTA, Atlanta Fleet 330, Jack Fasse, #3 the Croft, Atlanta, GA 30324.

\* Rescheduled from May

## Eagan Is Victor of Gulf Coast Championship

It would be hard to find a more suitable place for Snipe sailing than Bay St. Louis, Mississippi. Only a few miles west of Pass Christian, where the first ever Snipe was built and sailed, it is home for the Bay Waveland Yacht Club, which annually hosts this top-flight Gulf Coast Championship competition.

A remarkable variety of wind and sea conditions challenged a small but all-star studded fleet on April 19-20. Marc Eagan, one of this nation's best small boat sailors, and crew Kam Mitchell squeezed out a narrow one point victory over former Bay

### GULF COAST CHAMPIONSHIP (Top 5 of 15 Boats)

Skipper	Places	Points	Finish
Marc Eagan/Kam Mitchell	1-2-2	4.75	1
Buzzy Heausler/Gail Heausler	2-1-3	5.75	2
Hal Gilreath/Cheri Kerr	3-4-1	7.75	3
Kurt Wiese/Janet Gordon	5-6-4	15	4
Andy Lovell/C. Sharbonnet	4-8-5	17	5

Wavelander Buzzy Heausler and wife/-crew, Gail, who now hail from Davis Island Yacht Club.

The first race on Saturday was sailed in heavy air with a nasty short chop that put a real premium on upwind technique and provided some screaming wet reaches. Eagan took this race with Heausler in second and former Navy All-American Hal

Gilreath in third.

The second race was started in similar conditions, but the wind gradually died providing a light air beat to the finish. The Heauslers caught and passed Eagan to set-up a two boat duel in the final race

Sunday dawned stormy and rainy, forcing a two hour postponement as it was just too windy to venture out. Several boats packed up and headed home, missing what turned out to be perfect Snipe conditions. The wind shifted to the southwest, and this, being more offshore, meant smaller waves and optimum Snipe conditions. A maximum boatspeed beat was followed by two of the fastest and wildest reaches that this writer has ever experienced. Kurt Wiese with crew Janet Gordon had a narrow lead at the first mark, but was soon passed by Eagan.

The second beat saw the wind veer further to the west, favoring the boats that tacked inshore. Eagan held a narrow lead, but jibed to port, and was followed by the pack with the exception of Gilreath, who sailed off on starboard. It was soon evident that Gilreath, who was reunited with his Naval Academy crew, Cheri Kerr, had made the tactically superior move, as he had a nice lead at the bottom mark. He managed to hold on, and clinched a narrow win over the heavier Eagan, who clinched the title as the Heauslers crossed in third.

So once again Bay Waveland provided a perfect mix of sailing conditions, hospitality and facilities, leaving this sailor wondering why more Snipers won't support what could be one of the premier events in the nation.

Thomas Payne

## INDIANAPOLIS SNIPE FLEET 409 HOSTS THE 31st ANNUAL

# INDIANA OPEN

SEPTEMBER 6 - 7th, 1986

INDIANAPOLIS SAILING CLUB  
GEIST RESERVOIR

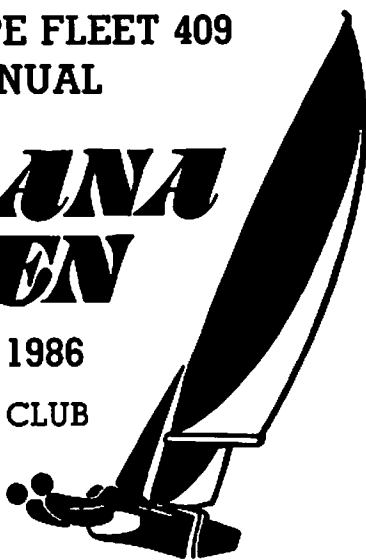

2 Series:  
Eli Lilly — 10 Trophies  
John Call — 10 Trophies  
Junior Race — Saturday A.M.

Post Race Refreshments  
Dinner  
Live Entertainment  
Continental Breakfast Sunday

Registration includes all above  
Advance Registration \$30.00 At table \$35.00

Camping on club grounds or lodging with fleet members available.

### Advance Registration Form

Skipper \_\_\_\_\_ Boat No. \_\_\_\_\_

Address \_\_\_\_\_ Hull Color \_\_\_\_\_

Crew \_\_\_\_\_ Housing Request \_\_\_\_\_

Make checks payable to: Snipe Fleet 409

Mail to: Randy Fridlund  
509 N. Ritter Avenue  
Indianapolis, Indiana 46201  
(317) 357-9415

**We Build  
the Fastest**

**Fiberglass Snipe**

**in the  
World!**

Alax Yachts  
D.W. Camet  
P.O. Box 83599  
San Diego, CA 92138  
(619) 224-6737

Alax Yachts Argentina  
Mario Isola  
CDE Correo No. 97  
Olivos (1636)  
Prov. Bs. Aires, Argentina

## Snipers Face Fog, Light Air In Northeasterns; Matt Fisher Triumphs

The Northeastern Snipe Regatta was sailed on Abino Bay, Lake Erie out of the Buffalo Canoe Club on the weekend of June 7-8. Thirty hearty Snipers and their crews showed up Friday evening at the club to register and check out the lay of the land. Register they did, but check the lay of the land . . . well, there was some fog.

Saturday's first race was started in light air and fog but the fleet managed to make it around the Olympic course before the wind died. Steve Callison won the race followed by Matt Fisher and Fritz Gram. Around 4 p.m. the breeze freshened and the second race commenced. Dick Mitchell won the nightcap followed by Steve Callison and Matt Fisher.

The keg party followed the races and all agreed that Labatts on draught was the way to fly. When the keg went dry some groups took a starboard tack into the dining room for dinner while others took the port to the bar. Those who missed the 9 p.m. deadline for the dining room trucked on down to Fort Erie for "Chinese."

Sunday morning was warmer, but what a fog bank covered Abino Bay! The 9:30 start had to be postponed because most of the fleet couldn't find the starting line let alone the committee boat. After half an hour the race was started in the dense shifty fog. The leaders went several hundred yards past the weather mark and had to run back with their poles up. Leo Murphy got lost, couldn't find the committee boat or the other Snipes and ended up backwards on the roller coaster at the Crystal Beach Amusement Park. Several of the leaders never did find the jibe mark. Matt Fisher

came out of the fog to win the race followed by Fred Rozelle and Leigh Savage.

The fourth race went in the diminishing fog with the breeze beginning to pick up. Fred Rozelle came across the line first with Eric Eiffert second and Matt Fisher third.

With a moderate breeze, 80 degree temperatures and a sunny sky, what one might call ideal sailing conditions, Fisher came home the winner of the fifth race and the regatta. Eric Eiffert finished second in the race and fourth overall. Fred Rozelle finished third in the last race and third in the regatta. Last year's bridesmaid, Steve Callison, did it again . . . just like Mom said. Sam Mollet rounded out the list "in the jingles."

The race committee, consisting of the Bryant boys, Matt Sr. and Jr. along with Jim Berry definitely had their hands full and did a super job of getting the five races in. Some hard decisions had to be made and they managed to call them right with consistent success. Susie Fretz and Laura Bryant did the scoring. The ladies auxiliary handled the registration and helped out newcomers to the club, while the Montgomerys ran the ship to shore radio to the committee boat.

Commodore Richard O'Connor, Fleet Captain Bruce Gunn and regatta co-chariman Bob Johnston passed out the Onieda Silver hardware at the awards ceremony and Id Crook spoke on behalf of the Snipe Class.

Rounding out the top 10 were Rick Wood, Leigh Savage, Tom Allen Sr. of the local club sailing Bill Buckles' new Snipe, Eric Gesner, and J. Ganson Evans.

Despite Mother Nature acting up with her fog banks, it was a great regatta with international competition at one of the finest facilities in North America.

*Bob Johnston  
Fleet 442*

### NORTHEASTERN CHAMPIONSHIP (Top 20 of 30 Boats)

Boat	Skipper	Fleet	Places	Points	Finish
23621	Matt Fisher	Hoover	2-3-1-3-1	9.5	1
24608	Steve Callison	Newport	1-2-4-4-9	19.75	2
25489	Fred Rozelle	Detroit	15-6-2-1-3	26.75	3
25781	Eric Eiffert	Newport	5-12-8-2-2	29	4
24087	Sam Mollet	Portage Lakes	8-9-15-6-4	42	5
26110	Rick Wood	Portage Lakes	6-20-10-5-5	46	6
25990	Leigh Savage	Detroit	13-14-3-13-20	63	7
26300	Tom Allen	None	18-7-14-14-10	63	8
26468	Eric Gesner	Newport	7-4-21-15-17	64	9
25888	J. Ganson Evans	Hoover	4-11-11-pms-8	64	10
16699	Fritz Gram	Cuba Lake	3-nf-7-20-6	66	11
25433	Jim Belford	Oakville	22-8-16-8-14	68	12
24116	Doug Nugent	Oakville	12-19-5-17-15	68	13
23978	Mark Bryant	None	17-5-nf-10-7	69	14
24688	Jack Mitchell	Oakville	21-13-9-9-18	70	15
23397	Jeff Mitchell	Oakville	20-18-6-11-16	71	16
25676	Dick Mitchell	None	9-1-13-ns-19	71.75	17
23625	J.R. Hand	Portage Lakes	16-16-23-7-11	73	18
26160	George Hock	Newport	10-21-18-18-13	80	19
25760	Steve Ray	Hoover	19-17-19-19-21	95	20

## CLASSIFIED

Classified ad rates ten cents a word. Minimum charge \$3.00. Ads accepted on a cash basis only. Send remittance for the proper amount. Forms close on the 1st of the month preceding publication. Ads received after that date will appear in a later issue.

**ACRYLIC SNIPE DRYSAIL COVERS**, yacht-acrylic will not rot, mildew, shrink or become brittle. Best cover material available. Outstanding workmanship. No. 1 full deck with 6" skirt for mast up and boom off. Flat type with halyard cockpit lifting bridle, \$139.50 white, \$145.00 blue. No. 2 same as No. 1 but has custom-looking tapered full skirt for ultimate protection. Zipper at bow for glove-like fit. \$175.00 white, \$185.00 blue, rudder cover \$19.50. Shipped UPS ppd. for orders with payment in full. Orders with 50% deposit are shipped balance COD including UPS charge. Contact Chris Rooke, (901) 744-8500.

**WEATHERMARK, INC.:** "The one-design specialists." **TOP COVER:** Full deck and top-side cover; including PVC/Polyester construction draw string skirt, velcro closures, tie down straps, halyard support, fully reinforced contact areas \$130 (white or blue). **SUPER PADDED:** Centerboard cover with carry handle \$49.00. Rudder cover \$35.00 (Both blue). **ONE-PIECE SUITS:** Red dinghy spray suit with suspenders \$69. All purpose suit 100% waterproof, taped seams \$95.00. **CONTACT:** David Pritchard, 6087 Holiday Road, Buford, Georgia 30518. (404) 945-0788.

Spare Water Rat (Tuttle) rudder, minimum weight, good shape, perfect condition. Best offer. Peter Commette, (305) 527-2800.

**CHUBASCO 20554.** Cobra mast, min weight, compass. White hull/blue deck, 2 suits sails, trailer. \$1,300. Ben Howe, Long Island. (515) 671-7898.

**MUELLER 24572.** White. New and used Shore sails. Compass. Good condition. \$2,000. Jon Conklin. (401) 331-7000, (401) 895-0306.

**FOR SALE:** Used sails, SUPER FAST!!! Save 70% buy fast proven sails!! Used Proctor and Cobra I masts. Write for details: Gonzalo Diaz, Sr., 5520 S.W. 72nd Ave., Miami, FL 33155. Call evenings (305) 667-0492.

**McLAUGHLIN 25409.** Fast, white hull/white deck, Cobra mast, once used jib, double deck trailer, covers. Reb Bartlett (312) 248-1840.

**FOR SALE:** 1972 Call Snipe 19345. Low center-board trunk, two sets of sails, racing compass, new ss halyards, new mahogany rub rail. B&W trailer with new wiring and lights. A lovely fast boat. Bruce Kirkham, 304 E. Wilmont Rd., Muncie, IN 47373. \$1,400.

**MUELLER 24329.** Excellent condition. Kelly green hull/light green deck. Shore sails. Tee Nee trailer — model 514S. \$3,000. Phone evenings (716) 318-3486. Rochester, NY. Ask for George.

**PHOENIX 23330.** Blue hull/white deck, Firestix mast, Ullman main, Sobstad jib, extra sails. Double ended controls, EZ loader trailer. \$3,000. California. (714) 536-1007.

## SUPPORT YOUR SNIPE CLASS

# **NORTH SAILS WINS . . . '85 WORLD'S**

**Snipe Sails Development is  
North's Goal for '86**



**Start this season with the same sails that won  
all major regattas in '85.**

**CALL OR WRITE TO—**

**North Sails One Design West  
1111 B Anchorage Lane  
San Diego, CA 92106 USA  
(619) 226-1415**

**12-9 Nagai  
Yokosuka, Kanagawa-Ken  
0 468-57-1262 Japan**

**Newgate Lane  
Fareham PO14 1BP  
Hants, England  
(0329) 231525**

**WE BUILD THE FASTEST SNIPE SAILS IN THE WORLD**