



SCIRA Rules and Sanctioned Regattas

A "SCIRA Sanctioned" regatta has special meaning to the membership. Sanctioning has been a means of assuring quality of race management and event organization from the early days of Snipe racing when this could not always be assumed. If a regatta is sanctioned by the SCIRA office, then the regatta organizers are assuring competitors that:

- All Snipes are measured properly and owners registered with SCIRA as indicated by the SCIRA decal, and the number on the sail is owned by the skipper of the boat.
- All SCIRA rules will be followed including sailing instructions, scoring systems, and guidelines for race courses and conditions.
- A SCIRA Representative will be designated at major events to assist the race committee and assure that all SCIRA rules are followed.

The concept of sanctioning is critical to the functioning of the organization and will be maintained for selected major, national and international events. However, there is discussion of modernizing and enhancing the process

of regatta sanctioning to allow for gradual changes in the sailing community.

Multi-class regattas are becoming a more and more important part of the sailing world, especially at the local and regional level. In these cases, imposing SCIRA rules can sometimes be viewed as a difficult imposition on the non-Snipe regatta organizers. Many times, a fleet may have a local regatta with the goal of promoting the Class by allowing non-Snipe-owners to sail in a regatta. This is against the rules in a sanctioned event, but certainly common sense tells us we need to do everything we can to market and promote the Class and we don't want our rules getting in the way.

To accomplish these sometimes conflicting objectives, it is possible that we need some new, more flexible levels of SCIRA Event Sanctioning. As an example:

- **SCIRA Championship Event:** Same definition as SCIRA Sanctioning exists today. To be used for World, National, International, and other championship events. These are solely SCIRA events where only Snipes are being sailed.

- **SCIRA Sanctioned Events:** Used for multi-fleet and other events where not all SCIRA rules can be followed but the regatta organizers and SCIRA are assuring quality race management and event organization. SCIRA membership *should* be required. A SCIRA Rep. may or may not be assigned. Regional and local SCIRA officers will be relied upon to coordinate with the SCIRA office to assign this status.

- **SCIRA Recognized Event:** Used for local, fleet, and/or low level regional regattas. Membership may or may not be required. Local and regional race courses and sailing instructions may be used. The regatta *will* be listed and publicized in the Snipe Bulletin (if submitted). The event's major intent may be promotional, marketing or experimental in nature.

This is only one example of how we might expand our event sanctioning process to more accurately reflect the realities of today's sailing world. What do you think? Write or e-mail your thoughts.

— Lee Griffith

Letters to/ from the Editor

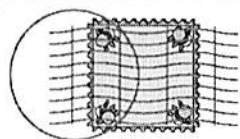

Dear Sirs:

Being 80 years with out my daughter as crew I don't sail my Snipe down the Chesapeake anymore. All mahogany solid African plywood hull, it is still in pristine condition – now over 30 years old. I manufactured all the hardware and mast including blocks and have a 18-8 stainless steel daggerboard. The completed boat took 1 1/2 years to build. I never joined a fleet because of location. However, I still like to retain membership and support SCIRA.

Respectfully,
L.C. Boller

Bear With Us!

The SCIRA office is in the middle of a database transfer. This Bulletin mailing is off the new database, so please check your address label for corrections and notify the SCIRA office immediately.

Also, please notify us if you are receiving duplicate copies or any other mailing problems that may have occurred.

The new database, under the guidance of Lincoln Snipe fleet members John & Mary Buckley, is all encompassing, including dues payments worldwide, boat number issuance, address, phone/fax/e-mail, fleet captain & officer information and all boat information including owners & MDS!

Around the Snipe World

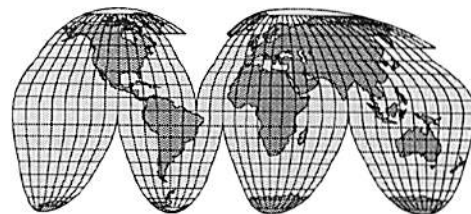

Many address changes were received after the recent Feb/March Bulletin directory printing. Get your pencils out!

Vice Rules Chairman Giorgio Brezich:

Fax number changed: +39-040-304-273

Brazil National Secretary – Alvaro Fonseca, Jr.

Almeda Cesar Nascimento, 322-67

Jurerê, Florinopolis, SC Brazil, 88053-400.

E-mail: danilo-casa@iguatemi-ltda.com.br

Chile National Secretary – Jorge González

Fax: +56-2-632-2689, E-mail: marcialg@entelchile.net

Colombia National Secretary – Mariana de Isaza

E-mail: mil@impsat.net.co

Member At Large & Norway National Secretary – Birger Jansen

Telephone & Fax: +47-66-849-509

US Fleet Captain Changes:

Atlanta: Bill Moss;

2325 Brandon Ct.,

Marietta, GA 30066, 770-591-8106,

e-mail: wcmoss@lucent.com

Barneгат Bay: John Manderson,

75 1st St, 2nd Floor,

Keyport, NJ 07735, 908-203-0188

Gull Lake: Jim Richter,

#13 Mill Run,

Fishers, IN 46038, 317-773-2169

**Rules Committee Member,
Antonio Bari:**

E-mail address change:

antonio.bari@eclipse.it

2000 World Masters

E-mail address in January Bulletin was incorrect, please contact Bjarne Iversen at: b.iversen@email.dk

District 2 Championship Dates Changed:

June 26-27, Lincoln, NE

SCIRA Rules and the Rule Book 2000

RUDDER: Add to our rule this sentence: "The tiller must not project beyond the aft edge of the rudder head". Since the advent of the aluminum tube tiller, sailors are often seen with this tube projecting as much as 12" behind the boat. Safety issue, in part.

TACK-TICK: "Tack-Tick", an electronic/solar powered combination timer, compass, tactical advisor, has been developed by a British company, and they have asked for approval of their device for use during races. SCIRA rules specify no electronic devices of any kind with the exception of timing devices. This proposal got a negative reception recently in the US at a meeting of Class officers and others. Currently cost is quite high, but prices of all electronic gear are tending downward, while alcohol compasses are increasing in price. At some point an electronic compass will come along that will be cheaper than our traditional ones.

ROPE STAYS: Although SCIRA rules were written with the idea of wire standing rigging in mind, no where are rope side stays specifically prohibited. With the advent of newer stronger rope technology the Class needs to decide whether to make the wire restriction permanent or to allow side stays made of some of the newer ropes that are currently available at costs comparable to wire.

RULE 48: Page 47: Rewrite last sentence to allow "light elastic line (shock cord)" to also be used to take slack out of headstay. This is to make clear that a common and harmless practice is legal.

MAINSAIL HEADBOARD (drawing, page 55): Add wording to the drawing specifying that "maximum allowable projection of sail cloth beyond the headboard shall be 12 mm." This question arose at the Worlds in San Diego and some sailmakers feel they could, by folding the cloth several times make a sail that is noticeably larger in the head than current sails.

RUDDER WEIGHT: Add sentence to Rule 38 "Weight up to a maximum of 450 g. may be permanently attached to rudders". Rule 38 states (in part) that rudders should weight a minimum of 6 lbs. Since this rule was approved measurers have allowed sailors to attach weight to a rudder that does not meet this minimum weight. As the rule was written to encourage strongly built rudders, there should be a limit to the amount of weight that can be added.

KICK-UP RUDDERS: Request from a European sailor that kick-up rudders be allowed in local races and regattas. Currently our rules allow them ONLY in local races, not in any "regattas or championships". If this restriction is relaxed, kick-up rudders still would not be allowed in national and international championships.

Herb Shear Spring Invitational

April 24-25, 1999
Mission Bay YC
&
Fleet 495

Come test your skills on the bay courses that will be used at the 1999 US Nationals later this summer. Dust off those winter cobwebs, tune up those tactical midns and get set for summer with some great Mission Bay racing.

- 6 races scheduled - 1st gun 11:50
- Registration starts at 8 am Sat.
- Steak/Chicken/Fish BBQ Sat. night

For more info:
Chris Snow: 619-226-1415(w)
619-224-3329 (h) or
chris@od.northsails.com

or
Chuck Sinks: 619-450-4336 (w)
619-223-6872(h) or
gowinccs@aol.com

The Tradition Continues...

- Sails 1st 1997 Gamblin Series/Winter Circuit
- Covers 2nd 1997 U.S. National Championships
- Masts 3rd 1997 District 6 Championships
- Booms 1st U.S. Finisher (3rd Overall)
1996 Western Hemispheres
- Rigging 3rd & 4th 1996 U.S. Nationals

Featuring our Mylar Mag2 jib with glued seams, no stitching!

For more information on our sails, please contact us at:

Ullman Sails

410 - 29th Street
Newport Beach, California 92663
Phone - 714/675-6970
Fax - 714/675-6276
Email - ullman@ullmansails.com



1999 DonQ Results

Coconut Grove Sailing Club
Miami, FL
March 13-14, 1999

Most of the people made the trek from Clearwater to Miami and were greeted with slightly warmer temperatures and a bigger breeze. A few newcomers arrived to boost the regatta tally to 42 entrants. Three races were held on Saturday in a SE 12-15 breeze that built into the upper teens. The chop was big too, creating tired bodies by the end of the day, but the flying reaches left smiling faces! The first race was a long one: a 5 leg W/L course with a mile+ windward leg, the kind where you have a hard time seeing the weather mark until halfway up the beat! The second

2 races were slightly shorter double triangles. The consistency of George Szabo/Carol Newman Cronin showed with the duo posting 3 bullets followed by the consistency of Andrew Pimental/Sherry Welch with 3 seconds and Augie Diaz/Pam Kelly with 3 thirds!

The regatta finished off with a single race in a 15 knot Southerly. The chop was diminished compared to Saturday, and the breeze backed off a little on the second triangle. Jimmie Lowe and Gavin McKinney of the Bahamas gave the leaders a run for their money and Diaz/Kelly pulled into first ahead of Szabo and Pimental who were duking it out. Unfortunately, Lowe/McKinney fouled Szabo/Cronin at the finish, and with 2 circles to do, gave him a 4th by the time he crossed the finish line. AP/H was flown after the finish to get the fleet back to the dock before the impending forecasted thunderstorms which

proved to not be a problem. The boats were all packed up and trophies awarded in plenty of time as the breeze picked up throughout the afternoon. Henry Filter/Lorie Stout (Annapolis, MD) and Hal Gilreath/Alex Stout (Atlanta, GA/Annapolis, MD) were 4th and 5th overall to round out the top five. Alex / Lisa Pline (Annapolis, MD) had a 6,5 in the first two races but dropped to 12th after a broken jib halyard fitting and a broken jib lead forced a retirement in the third race. They were solidly in seventh at the time.

Final Results

Pos	Sail#	Bow#	Helmsman	Crew	Race 1	Race 2	Race 3	Race 4	TotPts	Pos
1	29672	90	GEORGE SZABO	CAROL CRONIN	0.75	0.75	0.75	2	4.25	1
2	29499	83	ANDREW PIMENTAL	SHERRY WELCH	2	2	2	3	9.00	2
3	28810	25	AUGIE DIAZ	PAM KELLEY	3	3	3	0.75	9.75	3
4	28702	68	HENRY FILTER	LORIE STOUT	7	8	4	6	25.00	4
5	29324	52	HAL GILREATH	ALEX STOUT	12	10	5	5	32.00	5
6	28812	27	GONZO DIAZ	SHERRY ELDRIDGE	14	6	6	9	35.00	6
7	29204	72	LEE GRIFFITH	LISA GRIFFITH	5	9	15	8	37.00	7
8T	25948	55	ETHAN BIXBY	TRUDY BIXBY	4	12	11	14	41.00	8T
9T	29450	58	BIRGER JANSEN	LIV ULVEIE	8	7	9	17	41.00	9T
10	28811	32	JIMMY LOWE	GAVIN MCKINNEY	25	4	12	4	45.00	10
11	29147	67	ALEX PLINE	LISA PLINE	6	5	30DNF	13	54.00	11
12	28672	71	JIM RICHTER	WATT DUFFY	20	22	8	7	57.00	12
13	29148	76	CRAIG BEARDSLEY	MIMI BEARDSLEY	24	19	7	11	61.00	13
14	28814	26	GONZALO DIAZ SR	GREG SALDANA	16	15	19	12	62.00	14
15	29552	64	GREG FISHER	JERELYN BIEHL	17	18	13	15	63.00	15
16	28852	79	NED JONES	WHITNEY RUGG	13	14	21	19	67.00	16
17	27363	56	ERNESTO RODRIGUEZ	PAVEL NARANJO	15	17	18	18	68.00	17
18	29702	49	JACK FRANCO	LORI LOWE	10	13	14	42DNC	79.00	18
19	29014	75	DON HACKBARTH	YUKI YANAGA	26	20	20	16	82.00	19
20	29210	62	ROBERT DUNKLEY	TED SMITH	9	26	42DNC	10	87.00	20
21	28694	77	LINDA WENNERSTROM	MEGAN GAILLARD	19	23	10	42DNC	94.00	21
22	28044	48	PEDRO LORSON	MIMI BERRY	21	24	28	22	95.00	22
23	29592	86	PAUL CRONIN	KERRY FISHBACK	47OCS	11	16	24	98.00	23
24	28065	73	JOHN MANDERSON	MAGGIE MANDERSON	18	21	17	42DNC	98.00	24
25	24776	47	KEVIN DOWNEY	CRISTI STROUD	22	33	30DNF	20	105.00	25
26	25407	5	WILLIAM SCHOENBERG	LIZZ CINTRON	33	32	30DNF	21	116.00	26
27	28955	87	CAROLYN BROWN	SCOTT LINDLEY	23	30	24	42DNC	119.00	27
28	24702	21	JERRY THOMPSON	ALAN CAPELLIN	31	16	30DNF	42DNC	119.00	28
29	28468	78	JOHN PAPADOPOULOS	STEPHANIE FAILLERS	28	25	26	42DNC	121.00	29
30	27410	65	HALVOR POULSSON	EDEL RAGER	27	29	27	42DNC	125.00	30
31	29511	59	E. MONTARROYOS	E. MONTARROYOS	29	35CNF	22	42DNC	128.00	31
32	29442	63	CARR MOODY	RICK JARCHOW	32	31	23	42DNC	128.00	32
33	29114	91	PETER COMMETTE	MORGAN COMMETTE	11	36DNF	42DNC	42DNC	131.00	33
34	2814	74	GAVIN O'HARE	NANCY GILREATH	38DNF	28	25	42DNC	133.00	34
35	28628	82	JOHN HILL	CHRIS HURST	34	35	29	42DNC	140.00	35
36	29400	34	BILL WELCH	ANNE ROGERS	38DNF	42DNC	42DNC	23	145.00	36
37	25054	54	JERRY BLOUIN	PRISCILLA DUFFY	38DNF	42DNC	42DNC	25DNF	147.00	37
38	29256	61	KENT HEITZINGER	ROBERT ALEXANDER	30	34	42DNC	42DNC	148.00	38
39	24020	57	TOM PARKS	BONNIE ROBERTSON	35	42DNC	42DNC	42DNC	161.00	39
40	25374	66	JOHN UCHINO	JENNIFER TISTHAMMER	36	42DNC	42DNC	42DNC	162.00	40
41T	25659	89	RAY SCHMIT	DIANA MARSH	38DNF	42DNC	42DNC	42DNC	164.00	41T
42T	25995	92	CONNIE COMMETTE	SHEEHAN COMMETTE	38DNF	42DNC	42DNC	42DNC	164.00	42T

1999 Baleares Championship

Menorca, Spain

This weekend, Saturday, Sunday and Monday, we celebrated the Baleares Championship at the Bay of Ciudadela (Balears). The first day we raced the first two races, with the wind blowing SE 5-10 knots, with the following results:

First race:

1. Fernando Rita/Javier Sintes
2. Jaime Bagur/Luis Mesquida
3. Pedro Saura/Arturo Barranco

Second race

1. Damian Borrás/José Jaén
2. Toni Pons/J. Manuel Morales
3. Cristóbal Bosch/Pedro Alles

The second day, we could only run two of the three races scheduled, because it was blowing North wind, 20-27 knots all the time,

increasing at the end of the day, so had to go to the Club just after the second regatta. Only seven of the twenty nine crews could finish both races, and many incidents happened. Many capsizes, Fernando broke the mast, Damian and Cristóbal Bosch, the sails, etc. The results were:

Third race:

1. Fernando Rita/Javier Sintes
2. Cristóbal Bosch/Pedro Alles
3. Toni Pons/J. Manuel Morales

Fourth race:

1. Toni Pons/J. Manuel Morales
2. Sebastian Mesquida/Bep Pons
3. Pedro Pons/Simon de Olivar

The third day, Monday, we could not sail because the wind did not blow lower than 27 knots during all the day, so the final general results were:

Overall Results

- | | |
|--------------------------------|------------|
| 1. Fernando Rita/Javier Sintes | 5.50 pts. |
| 2. Toni Pons/J. Manuel Morales | 5.75 pts. |
| 3. Cristóbal Bosch/Pedro Alles | 9.00 pts. |
| 4. Damian Borrás/José Jaén | 9.75 pts. |
| 5. Jaime Bagur/Luis Mesquida | 13.00 pts. |

It is remarkable the great level of all the competitors racing, and the difficulty of getting classified among the first ten positions.

—Pedro Pons Morales

SEITECH Launching Dolly

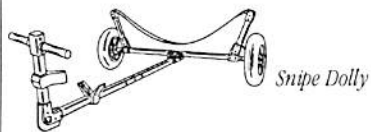

Snipe Dolly

Ideal for launching, moving, and storing your boat. Light, strong, corrosion-proof, maintenance-free. Aluminum frame, engineered plastic joint components, stainless steel fasteners, 3" wide sling, and pneumatic ATV wheels with plastic rim & Delrin needle bearings. Rolls easily over sandy and rocky beaches.

Comes as a kit. Easy to assemble, no-tool breakdown into 3 pieces. UPS shippable. One year warranty.



Choose our 16 x 6, 9.5 x 19, or 11 x 22 ATV Wheels.

We've got a dolly for any dinghy!

SEITECH Marine Products, Inc.
 PO Box 514, Portsmouth, RI 02871 USA
 Tel: 401-683-6898, Fax: -6897
 E-Mail: Set52@aol.com Web: www.seitech.com

Encuentro Master del Rio de la Plata

Meeting of the Masters of the Rio de la Plata, Argentina
 March 6,7, 1999

The races took place in Club Nautico Olivos, Buenos Aires, March 6-7. The Championship brought together old Snipe sailors Dany Ujvary, Pedro Sisti, and Julio Labandeira among many others. The Chairman of the regatta was another old Snipe sailor, Jorge Sanjurjo. Brasilians, Uruguayans and Chilean sailors were also invited, but they were unable to attend.

All races were sailed in light winds, from the North at first, turning slowly to the SouthEast in the afternoon. The water was choppy with a moderate tide from the NorthWest. Upwind there were small windshifts so good speed and tactics were very important, as well on the downwind legs. All the races were won by our newest Master, Johnny MacCall, who sailed with a very light crew of Christian Giacomelli, an older Snipe sailor as well.

The Brothers Fumagallo sailed consistently with their older wooden boat 12103 and they finished second overall. Close racing in all races was between Nucho Sisti/Andrés Marcone and Julio Labandeira/Berena Zani and Dany Ujvary/H. Longarella.

The Club Nautico Olivos held a great social party and reunion for all the sailors. The next meeting of the Masters will be in June at the Yacht Club Rosario.

—Eduardo Fumagallo

1-28962	MAC CALL-GIACOMELLI	1-1-1-1-1	4.00
2-12103	FUMAGALLO-FUMAGALLO	2-3-2-2-3	9.00
3-28647	LABANDEIRA-BERENA	5-2-4-4-2	12.00
4-29345	SISTI-MARCONI	4-4-3-3-5	14.00
5-28982	UJVARY-LONGARELLA	3-5-6-6-4	18.00
6-28642	ISERN-GUASONI	6-6-5-5-6	22.00
7-29012	AGUSTI-SAUL	7-8-8-7-7	29.00
8-2869	RAWSON-LONGARELLA	8-7-7-8-8	30.00

Regatta Chairman and Fleet Captains

Remember to send your regatta results and photos to the SCIRA office for publication in the Bulletin.

E-mail, fax or mail

Come for the fun, stay for the regatta (but be sure to come for the fun)

1999 US Nationals - Mission Bay

Two words best sum up the Mission Bay YC feeling: Casual Ambiance. MBYC is a beach club with boats, and the facility is perfectly positioned along one of the most scenic and desirable sections of the city. San Diego is already one of the most popular vacation cities in the country, and the Mission Beach and Mission Bay areas are prime reasons for it.

It could easily be said that the origin for the SCIRA anthem "Serious Sailing, Serious Fun" is rooted in Mission Bay Snipe Fleet 495. And for the 1999 Nationals, when you are not taking advantage of the fine racing conditions that has produced 4 of the last 5 national champions, you will be served up some of the favorite local activities selected especially for you.

Let's take a look at the 1999 national's schedule:

Saturday: This is Day 1, and today you are either arriving, measuring or racing (Jrs and Women). MBYC's deck will be the setting for our P.M. activities. With the bay lapping at the sandy beach below, we will delight in pizza cats and our favorite cocktails. Road trips to San Diego and racing stories will fill the air. We will be perfectly comfortable in our shorts and sandals. Later on expect to be dragged down the street to some of Mission Beach's famous watering holes.

Sunday: Everyone should have arrived by now. Today there will be a real buzz in the air. Snipe nationals are about picking champions, being reunited with old friends and meeting the new "freshman class." If you have any extra time today, consider borrowing a bike for a ride around the bay. Or a surfboard to try out the July ocean swell that's just a walk across the street from the yacht club. If you are going for a sail, ask how to sail over to Sea World to check out the penguin pen. Later on we will have our official welcoming party and will salute the 1999 Junior and Women's National Champions. And much later on...perhaps a trip downtown to the much ballyhooed Gaslamp District of downtown San Diego.

Monday: The trick to enjoying the U.S. Nationals is not to get too worked up on the first day of racing. Easier said than done, but always the goal. Fortunately the racing today will be inside the bay, offering excellent spectating and short course racing. No grueling long hike-fest windward legs today. A highlight of the 1997 Worlds (hosted by MBYC) was the Earl Elms Fish Fry, and we are doing it again tonight. Multiple National and World champion, Earl is our most famous local celebrity. He is also among a number of snipe sailors who are fisherman by trade. Earl and his posse will put on an awesome show tonight that can not be missed.

Tuesday: This is always an exciting day, with it being the last day of qualifying and all. We thought we would add to that by going out to the site of the 1997 World Championships. Often lighter and shiftier than inside the bay, the ocean course does give us a chance to stretch out a little and gain an extremely picturesque view of the coastal area. The start line will be very near the Belmont Park

Rollercoaster, which many of you will have rode on by now. After racing, the plan is to head across the street for a Surf Safari Beach Bash. We will have surfboards for the high energy types, and beach games and barbecues for the rest. This time of year the sunset will be awesome!

Wednesday: Finally, the U.S. Nationals has begun. All the sailing is inside today, giving the fleet lake-like conditions...without the humidity, bugs and drifters so often found on real lakes. Just pure sailing with San Diego's steady seabreeze. At the end of the day we will be shedding our "game face" and heading off to the world famous San Diego Zoo. This is a real treat as the zoo will be preparing a specially catered party and dinner for us (hopefully not using any of the zoo residents as the entree). The park will be open to us as well, and some of the park highlights are "Hippo Beach," "Polar Bear Plunge," the Panda Bear Exhibit, and the children's zoo. For the night owls, the bright lights of downtown San Diego are just minutes away. Can anyone say, "last call?"

Thursday: Day 2 of the Nationals begins establishing the haves and the have nots. Some of us will be feeling good, but there are bound to be plenty with long faces. That's the problem with regattas. We all want to win, yet there is only one first place. And that's exactly why we party each night...everyone's a winner. Tonight's activities will responsibly start off with the annual general membership meeting. The class officers usually meet early in the week, and this is our chance to get up to speed on the important class issues. The discussion is opened up to the attendees, and if it is anything like correspondence on the class's Internet mailing list, this could be a lively affair. We will, however, throw fire at fire, serving up a tasty BBQ dinner. For those looking for further solace, we suggest heading toward south Mission Beach for sacred local shacks like "The Beachcomber" or "The Pennant." Has anyone seen the sunrise this week?

Friday: And the winner is...? By the end of today we will know the answer, and it will all be happening right off the docks of Mission Bay YC. No past nationals has ever had a venue like this one, where the spectators can watch the action WITHOUT binoculars. With the staggered starting schedule, even the racers are going to be able to watch. One of the highlights each year is after the scores are settled and the boats are packed. We all do a quick reality check with the results, and then permanently replace our "game face" with our "party face." Tonight we rage, and nobody throws a party like this place. Sure, we all don our formal wear to salute this year's kings and queens. But after that last speech, look for the locals (we are all locals by now) to head outside for the final beach party of the week. Drinks and dancing...all night long.

Nationals, and Beyond: It may be hard to believe, or even understand, but Saturday morning is the moment you have all been waiting for. The nationals are over, so now the "real event" can begin. To

Registration and social form will be in the next issue of the Snipe Bulletin or check the Snipe web page: www.snipe.org for more Nationals information.

those who believe the Whitbread Round the World Race is "the" endurance event of yachting, they have never been to the GFU 24 Hour Regatta. Plan to extend your adventure to include this one. We expect a record number of teams (one boat per team; at least 8 sailors per team) for the 19th rendition of the event, which includes continuous racing and partying for 24 hours. The race course begins at MBYC, takes the fleet around Vacation Island and back to MBYC, where each team must touch the dock before beginning the next lap. Team members can sail no more than two consecutive laps, so often teams are trading out personnel as well. Racing is always close through the night, and the team that first catches the Sunday morning seabreeze is usually the winner. There is always a band Saturday night too, and the party is great because nobody has to leave. Teams either stay up all night, or take naps in tents or cars (like all endurance events, there must be sacrifice). The good news about the GFU 24 Hour Regatta is that it ends at noon on Sunday, providing plenty of time for folks to start back on the homeward trail. Teams can be organized in advance or thrown together at the last minute. Be sure to include the GFU in your nationals plan!

—Craig Leweck

Your #1 Bird House!

- *Go-Fast Main & Jib Sheets!
- *Pole Launcher Kits
- *Custom Jib cars & plates featuring RONSTAN's Compact SMART RATCHET for 5/16" line. Small & Light!



- *Sea Sure gudgeons & pintles
- *Aigle & Douglas Gill boots
- *Henri Lloyd & Gill dinghy sailing suits
- *Full Service Rigging Shop
- *Snipe Experienced Staff!

Sailing Supply

2822 Canon St

San Diego, Ca. 92106

1-800-532-3831

SAILING_SUPPLY@msn.com

We'll Ship Anywhere in the U.S.A., Next Day Service.

1998 SCIRA High Point Championship Trophies

Henry Davis Wins both International Reichner and US Minneapolis for best scores.

The 1998 High Point Championship of SCIRA saw an increase in participants from the previous year, with 179 entries reported from 14 fleets. Only 1 non-US fleet, Budworth, England fleet 217 reported internationally. Henry Davis of the Iowa-Nebraska Sailing Association, had the overall best score for 1998. Bob Rowland of Cowan Lake, Ohio and 1996 champion, finished 2nd overall. Neil Martin, last years Reichner winner, was 3rd overall. The oldest boat competing was Tom Davis from Lincoln, NE in 15301, with 4 boats under 20,000 competing. St. Petersburg, FL sailors filled the top 4 spots of most races completed, with Chris Klotz racking up 66 stars.

1999 April Bulletin
 The Snipe Bulletin

Name	Fleet	Boat #	# races	Total pts
18Henry Davis	INSA	28700	17	1731.41
28Bob Rowland	Cowan Lake, OH	28747	20	1730.4
3Neil Martin	Budworth, England	27106	11	1689
4Peter Wolcott	Quassapaug, CT	28656	21	1679.3
5D. Mendelkatt	St. Petersburg, FL	22773	40	1668
6Peter Frost	Seattle, WA	1665	18	1665
7Russell	Lincoln, NE	28881	22	1661.68
8Bob Ewocht	Lincoln, NE	25552	17	1658.94
9Packy Davis	San Francisco, CA	28215	26	1653
10Joe Norton	Green Lake, WI	28182	10	1653
11Shane Erickson	Quassapaug, CT	26202	28	1648.1
12M. Crompton	Budworth, England	26996	21	1644
13P. Hackney	Budworth, England	26734	33	1638
14Andy Zaisky	Green Lake, WI	28911	8	1631.4
15Alyden, Roussmaniere	Winchester, MA	25412	16	1631.31
16Juel Zackin	Quassapaug, CT	29111	27	1630.5
17Shawn Bennett	San Francisco, CA	26104	22	1629
18Pat Flood	INSA	25488	21	1624.95
19Carter Weitz	INSA	25486	24	1622.67
20Ted Garman	Seattle, WA	1617	37	1617
21Chris Klutz	St. Petersburg, FL	27270	66	1615.32
22Ethan Bucky	St. Petersburg, FL	25948	23	1615.17
23Jay Carey	Cowan Lake, OH	25420	17	1610.2
24William Worster	Cowan Lake, OH	25727	19	1603.6
25Bruce Kitchen	Cowan Lake, OH	27004	21	1603.4
26John Kuhnhausen	Atlanta, GA	24442	30	1602.13
27Ken Knass	Green Lake, WI	24690	13	1598.4
28David Lenoe	Winchester, MA	27101	15	1596.8
29Norm Dahl	Newport YC, NY	25370	10	1591.4
30Jarrel Price	Quassapaug, CT	25413	17	1586.8
31Matt Bryan	St. Petersburg, FL	29373	30	1580
32Don Hackbath	Atlanta, GA	29014	21	1578.48
33Bob Panza	Quassapaug, CT	25714	37	1577.1
34J. Love	Budworth, England	27098	32	1574
35Susan Lodico	Winchester, MA	24442	17	1573.58
36John MacRae	Winchester, MA	26451	8	1573.37
37Larry Briggs	Lincoln, NE	27372	22	1573.05
38Charles Courtsal	Newport YC, NY	28781	8	1572.88
39Bill Hall	Winchester, MA	28199	9	1570.44
40Ron Sandstrom	Winchester, MA	26448	6	1570.16
41Mary Jane Bumby	Green Lake, WI	26911	13	1569.1
42John Zaisky	Green Lake, WI	25432	11	1568.09
43Jack Wagener	Lincoln, NE	26882	15	1566
44Dustin Kays	Atlanta, GA	25751	28	1560.54
45John Briggs	Lincoln, NE	25731	6	1558.33
46Eugene Saroti	Winchester, MA	26999	5	1558
47A. Sampson	Budworth, England	28639	19	1556
48Mike Toohy	INSA	24100	20	1554.8
49M. Antonelli	Budworth, England	20323	16	1554
50Vince Caselana	San Francisco, CA	28856	26	1553
51Theodore Horvath	Newport YC, NY	26897	10	1551.2
52John Mulane	Winchester, MA	27591	11	1551.18
53Andy Pantous	San Francisco, CA	26843	26	1551
54John Hagman	St. Petersburg, FL	27027	44	1549
55Frank Pantous	Atlanta, GA	26100	20	1548.9
56Harry Lewinson	Winchester, MA	26894	10	1547.2
57Bill Hooper	Atlanta, GA	28500	23	1542.04
58Dave Patterson	Williamette, OR	27415	7	1540.4
59Peter Festeren	INSA	25052	17	
60John Tagliamonte	San Francisco, CA	29311	17	
61Keane	Lincoln, NE	24321	20	
62Jess Coburn	Atlanta, GA	28376	5	
63Peter Lapikse	Cowan Lake, OH	23455	16	
64G. Edwards	Budworth, England	26671	36	
65Cilll Wright	Seattle, WA	1523	42	
66Nancy Shriver	Seattle, WA	1516	35	
67Bob Dullner	Seattle, WA	1510	21	
68Paul Taylor	Seattle, WA	1505	6	
69Jim Lampros	Williamette, OR	24106	7	
70Phillip Morse	Newport YC, NY	28441	9	
71Mark Brown	Williamette, OR	23291	7	
72Bob Whitman	Cowan Lake, OH	27379	25	
73George Hood	INSA	25949	28	
74William Vaughn	Newport YC, NY	19119	8	
75Mitchel Rogers	St. Petersburg, FL	1474	15	
76Martha Rogers	Seattle, WA	1467	14	
77Ralph Swanson	Winchester, MA	29999	15	
78Mike Racker	INSA	26076	23	
79Bill Welch	St. Petersburg, FL	29400	38	
80Ed Weitz	INSA	28482	22	
81John Buckley	Lincoln, NE	28444	7	
82Steve Koestener	Quassapaug, CT	26337	23	
83Bill Moss	Atlanta, GA	27144	10	
84Jerry Kimble	Atlanta, GA	25627	27	
85Joe Donis	Winchester, MA	26452	15	
86William Flack	Cowan Lake, OH	24272	15	
87Dae Lockwood	Williamette, OR	27730	7	
88Woody Norwood	Atlanta, GA	29200	7	
89Gordon Hackstaff	St. Petersburg, FL	25172	20	
90John Lally	Winchester, MA	28542	11	
91Chris Stang	Atlanta, GA	22870	9	
92Jim Miller	Seattle, WA	1422	40	
93Collin Linahan	St. Petersburg, FL	1420	6	
94Ken Hardy	St. Petersburg, FL	1418	28	
95Pfor & Jane Huffeltr	INSA	24095	17	
96Joe Harvard	San Francisco, CA	26615	18	
97Martha Smith	Seattle, WA	1408	18	
98Bob Racker	INSA	27005	20	
99Bill Brush	INSA	27523	21	
100Neal Snobid	Winchester, MA	27099	19	
101Tom Voldrechi	St. Petersburg, FL	25428	15	
102Bob Foster	St. Petersburg, FL	26397	52	
103Martin Fraser	Winchester, MA	24999	5	
104Peter Oman	Winchester, MA	25708	14	
105R. Ross	Budworth, England	20349	31	
106Kevin Haller	Newport YC, NY	26298	10	
107Dave Carroll	Atlanta, GA	28224	7	
108Jamie Rabbit	St. Petersburg, FL	USF	19	
109Andy Trowyn	Green Lake, WI	21047	5	
110S. Ketham	Budworth, England	20350	17	
111Nigel Mendez	Winchester, MA	26488	6	
112Bob Sanders	Seattle, WA	1372	39	
113Doug Cleveland	Atlanta, GA	24265	9	
114Suant Reynolds	Seattle, WA	1364	16	
115M. Andrews	Budworth, England	20023	23	
116Neil Bogue	Seattle, WA	1362	8	

Lillia Snipe

Working together with the world's best sailors, we thought, designed and built...

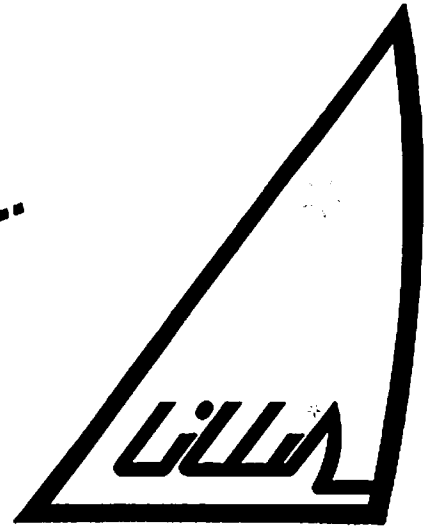

New Lillia Snipe

- Computer designed hull for the best all-around performance.
- Deck modified with the most comfortable hiking position.
- Deck hardware lay-out thought for more simplicity and access.

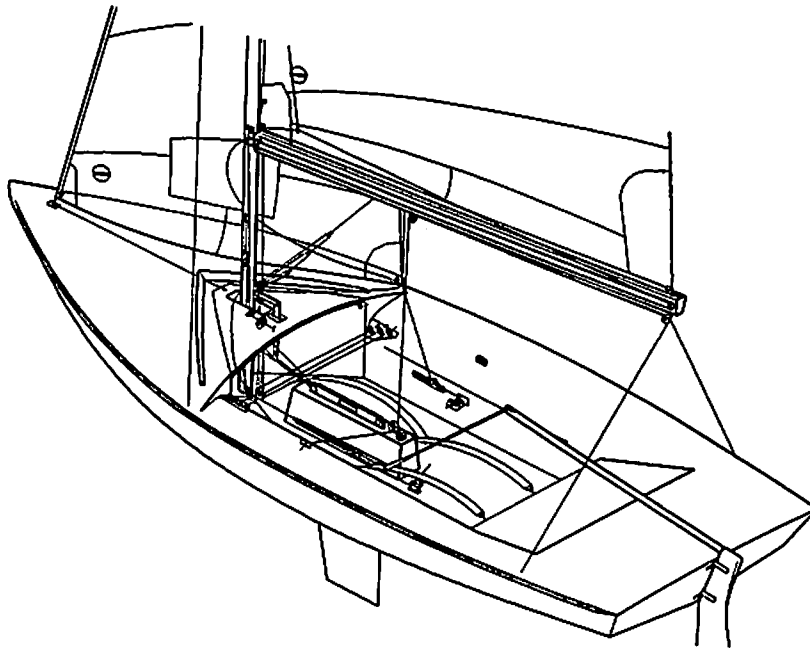

LILLIA BOATYARD - 22010 Musso - Como - Italy - Phone 0039-344-81223 Fax 0039-344-81568

LILLIA SOUTH AMERICA
Niterói - RJ
Phone - Fax 0055-21-616-2550

LILLIA NORTH AMERICA
190 Hagman Rd. - Winthrop, MA 02152
d- 617-539-0992 e-617-846-1772
Fax 617-539-0614